



**Washington State
Department of Transportation**

TECHNICAL MANUAL

Highway Runoff Manual

M 31-16.01

June 2008

Environmental and Engineering Programs

Design Office

Americans with Disabilities Act (ADA) Information

Materials can be provided in alternative formats: large print, Braille, cassette tape, or on computer disk for people with disabilities by calling the Office of Equal Opportunity (OEO) at 360-705-7097. Persons who are deaf or hard of hearing may contact OEO through the Washington Relay Service at 7-1-1.

Additional copies may be purchased from:

Washington State Department of Transportation
Administrative and Engineering Publications
PO Box 47304
Olympia, WA 98504-7304

Phone: 360-705-7430

Fax: 360-705-6861

E-mail: enrpubs@wsdot.wa.gov

Internet: www.wsdot.wa.gov/publications/manuals/

Get the latest information on updates to WSDOT engineering manuals —
join Engineering Publications Listserv today at:

www.wsdot.wa.gov/publications/manuals/maillinglist.htm

Highway Runoff Manual Table of Contents

Chapter 1. Introduction	1-1
1-1 Basis for Manual Development.....	1-1
1-2 The Importance of Stormwater Management.....	1-8
1-3 Organization of This Manual	1-11
1-4 How to Use This Manual.....	1-12
Chapter 2. Stormwater Planning and Design Integration	2-1
2-1 Introduction	2-1
2-2 Stormwater Management Objectives	2-1
2-3 Project Development Overview	2-1
2-4 Developer Projects	2-12
2-5 Stormwater Facility Design Approach	2-13
2-6 Special Design Considerations.....	2-14
2-7 How Stormwater Management Applies to a Project.....	2-19
Appendix 2A. Engineering and Economic Feasibility Evaluation	
Chapter 3. Minimum Requirements.....	3-1
3-1 Introduction	3-1
3-2 Applicability of the Minimum Requirements	3-2
3-3 Minimum Requirements.....	3-7
3-4 Stormwater Retrofit Guidelines.....	3-31
Chapter 4. Hydrologic Analysis.....	4-1
4-1 Introduction	4-1
4-2 Project Considerations.....	4-2
4-3 Western Washington Design Criteria.....	4-9
4-4 Eastern Washington Design Criteria	4-29
4-5 Infiltration Design Criteria	4-44
4-6 Wetland Hydroperiods	4-80
4-7 Closed Depression Analysis.....	4-80
4-8 References	4-84
Appendix 4A. Web Links	
Appendix 4B. TR55 Curve Number Tables	
Appendix 4C. Eastern Washington Design Storm Events	

Chapter 5. Stormwater Best Management Practices	5-1
5-1 Introduction	5-1
5-2 Types and Functions of Permanent Stormwater BMPs.....	5-2
5-3 BMP Selection Process	5-10
5-4 BMP Design Criteria.....	5-29
5-5 Operation and Maintenance.....	5-217
5-6 References	5-232
Chapter 6. Temporary Erosion and Sediment Control Design Guidelines and Process	6-1
6-1 Introduction	6-1
6-2 Temporary Erosion and Sediment Control (TESC) Plan	6-1
6-3 Spill Prevention Control and Countermeasures Plan	6-19
6-4 Water Quality Sampling and Reporting Procedures	6-20
6-5 Standard Sampling Procedures.....	6-20
6-6 Office Data Recording and Analysis.....	6-23
6-7 Reporting Sampling Results and Compliance Issues	6-23
6-8 NPDES General Construction Permit Sampling Procedures	6-24
6-9 In-Water Work Monitoring	6-30

Appendix 6A. Best Management Practices

CHAPTER 1

Introduction

Chapter 1. Table of Contents

Chapter 1.	Introduction	1-1
1-1.	Basis for Manual Development	1-1
1-1.1.	Purpose, Need, and Scope	1-1
1-1.2.	Review Process and Regulatory Standing of the Manual	1-2
1-1.3.	Presumptive vs. Demonstrative Approaches to Protecting Water Quality	1-3
1-1.4.	Overview of Manual Development	1-4
1-1.5.	Overview of Federal, State, and Local Regulations Related to Stormwater	1-5
1-1.5.1.	Phase I NPDES Municipal Stormwater General Permits	1-5
1-1.5.2.	NPDES Construction Stormwater General Permit	1-5
1-1.5.3.	Phase II NPDES Municipal Stormwater General Permits	1-6
1-1.5.4.	Local Requirements	1-7
1-2.	The Importance of Stormwater Management	1-8
1-2.1.	Background and Objectives	1-8
1-2.2.	Impacts of Roadway Runoff	1-9
1-2.3.	Management of Runoff From Transportation Projects	1-9
1-3.	Organization of This Manual	1-11
1-4.	How to Use This Manual	1-12

Chapter 1. Introduction

1-1. Basis for Manual Development

1-1.1. Purpose, Need, and Scope

The *Highway Runoff Manual* (HRM) was developed to direct the planning and design of stormwater management facilities for new and redeveloped Washington State highways, rest areas, park-and-ride lots, ferry terminals, and highway maintenance facilities throughout the state. The Washington State Department of Transportation (WSDOT) manages its stormwater discharges to protect water quality, beneficial uses of the state's waters, and the aquatic environment in general. Conformance to the provisions of this manual will result in consistent design procedures statewide and should support acceptance of WSDOT stormwater planning by regulatory agencies. Guidelines are provided for both western and eastern Washington, taking into account variations in climatic, geologic, and hydrogeologic conditions.

This manual's approach is consistent with WSDOT's objective of implementing a statewide highway runoff program that applies sound engineering principles to satisfy federal and state requirements. While federal and state stormwater requirements are subject to change, this manual is based on the best practicable engineering approaches to stormwater management currently available for WSDOT facilities.

The HRM establishes minimum requirements and provides uniform technical criteria for avoiding and mitigating impacts to water resources associated with the development of state-owned and -operated transportation infrastructure systems and for reducing and minimizing water resource impacts associated with the redevelopment of those facilities. The manual will receive periodic updates to enhance content clarity, as well as reflect changes in regulations, advances in stormwater management, and improvements in design tools. To ensure you are using the most current design criteria, users referencing printed copies and CD ROM versions of the manual should continually consult the HRM Resource Web Page (www.wsdot.wa.gov/Environment/WaterQuality/Runoff/HighwayRunoffManual.htm) for postpublication updates. To receive e-mail announcements regarding HRM-related updates, training opportunities, and improvements in design tools, send a blank e-mail to: subscribe-stormwater_list@lists.wsdot.wa.gov. You will then receive an e-mail asking you to confirm your subscription.

Primary users of this manual include:

- WSDOT engineers who design drainage systems and develop Hydraulic Reports; temporary erosion and sediment control (TESC) plans; and spill prevention, control, and countermeasures (SPCC) plans.

- WSDOT project inspectors in construction project offices responsible for inspection and maintenance of TESC plans.
- WSDOT maintenance staff responsible for developing roadside management plans and roadway maintenance practices.
- Developers of projects adjacent to WSDOT right of way that are linked to roadway and drainage facilities within the right of way.
- Consultants hired to develop Hydraulic Reports, TESC plans, and SPCC plans or design stormwater facilities for WSDOT.
- Counties, municipalities, and other jurisdictions that design transportation projects supported by federal or state funding.

The Headquarters (HQ) Hydraulics Section and the HQ Environmental Services Office (ESO) are jointly responsible for manual revisions and implementation oversight. The design criteria and procedures presented in this manual supersede conflicting information presented in other previously published WSDOT manuals.

Many aspects of stormwater management for environmental protection relate to drainage collection and conveyance systems, culverts, drainage outfalls, and a variety of other hydraulic features. This manual makes frequent references to the *Hydraulics Manual*, which is dedicated in large part to addressing the analysis and design of hydraulic features. The intent is that the two manuals are to be used in tandem for complete analysis and design of stormwater facilities for roadway and other transportation infrastructure projects.

1-1.2. Review Process and Regulatory Standing of the Manual

The *Highway Runoff Manual* (HRM) covers the entire state and meets the level of stormwater management established by the Washington State Department of Ecology (Ecology) in its *Stormwater Management Manual for Western Washington* (SMMWW) and *Stormwater Management Manual for Eastern Washington* (SMMEW). Stormwater management requirements for Washington State were developed to protect receiving waters from the adverse hydrologic change and water quality degradation that can occur with project development. The requirements vary for western and eastern Washington due to differences in climate, soils, receiving water characteristics, and environmental concerns. Ecology has been involved in a review capacity throughout the development of this manual.

The guidelines and criteria in the HRM also support WSDOT in its efforts to comply with the requirements of the federal Endangered Species Act (ESA). National Oceanic and Atmospheric Administration (NOAA) Fisheries and the United States Fish and Wildlife Service (USFWS) did not formally review the Ecology stormwater management manuals for programmatic “concurrence” under the ESA. Thus, to accomplish WSDOT’s objective to develop stormwater management design criteria that meet all regulatory requirements, NOAA and USFWS were invited to comment on the HRM during the development process.

1-1.3. Presumptive vs. Demonstrative Approaches to Protecting Water Quality

This manual is intended to provide project engineers and designers with technically sound stormwater management practices, equivalent to guidance provided in Ecology's stormwater management manuals, to achieve compliance with federal and state water quality regulations through the *presumptive approach*. Engineers and designers have the option of not following the stormwater management practices in this manual and seeking compliance via the *demonstrative approach*. However, this requires (1) demonstrating that the project will not adversely impact water quality by collecting and providing appropriate supporting data to show that the alternative approach protects water quality and satisfies state and federal water quality laws, and (2) performing the technology-based requirements of state and federal law.

Both the *presumptive* and *demonstrative approaches* are based on best available science and result from existing federal and state laws that require stormwater management systems to be properly designed, constructed, maintained, and operated to:

- Prevent pollution of state waters and protect water quality, including compliance with state water quality standards.
- Satisfy state requirements for all known available and reasonable methods of prevention, control, and treatment of wastes prior to discharge to waters of the state.
- Satisfy the federal technology-based treatment requirements under 40 CFR Part 125.3.

Under the *demonstrative approach*, the timeline and expectations for providing technical justification of stormwater management practices depend on the complexity of the individual project and the nature of the receiving water environment. In each case, the engineer or designer may be asked to document, to the satisfaction of Ecology or other approval authority, that the practices selected will result in compliance with the water quality protection requirements of the permit or of other local, state, or federal water quality-based project approval conditions. This approach may be more cost-effective for large, complex, or unusual types of projects.

Projects that follow the stormwater best management practices (BMPs) contained in this manual are presumed to have satisfied this demonstration requirement and do not need to provide technical justification to support the selection of BMPs. Following the stormwater management practices in this manual means adhering to the criteria provided for proper selection, design, construction, implementation, operation, and maintenance of BMPs. This approach will generally be more cost-effective for typical WSDOT projects.

1-1.4. Overview of Manual Development

The original *Highway Runoff Manual* was published in 1995 for primary application in the Puget Sound basin. The manual was designed to be consistent with Ecology's *Stormwater Management Manual for the Puget Sound Basin* (published in 1991), with specific guidance for transportation projects. The *Stormwater Management Manual for the Puget Sound Basin* became obsolete when Ecology published the SMMWW. Ecology's publication of the SMMEW provided the first comprehensive stormwater management manual for the eastern areas of the state. The guidance included in these two manuals forms the basis for this revised HRM and supports WSDOT's mission by providing technical and uniform criteria consistent with the intent of Ecology's stormwater guidance for all areas of the state.

This manual represents a culmination of years of extensive research, collaboration, and negotiation by an interdisciplinary technical team made up of water quality, stormwater, and erosion control specialists; designers; hydrologists; geotechnical and hydraulics engineers; landscape architects; and maintenance staff. The technical team also included several county representatives and benefited from a close working relationship with Ecology staff (with work also contributed by consultants and outside reviewers). The technical team recognized that it is inefficient, and in some instances ineffective, to attempt to emulate how local jurisdictions manage runoff from residential, commercial, and industrial land uses. Consequently, its approach to revising the manual took into consideration the following:

1. WSDOT needs a statewide approach for managing stormwater that recognizes the differences in climate, soils, and land uses in eastern and western Washington.
2. Highway projects are linear in nature and, as such, are faced with practical limitations in terms of locating and maintaining stormwater management facilities within state-owned right of way.
3. WSDOT has limited control over many pollution sources entering its right of way, such as pollutants generated from atmospheric deposition, vehicle operation, litter, organic debris, and surrounding land uses.
4. The option to discharge runoff to local jurisdictions' drainage systems is not always available.
5. WSDOT lacks funding mechanisms (such as stormwater utility fees) and land use controls (such as zoning and land use ordinances) available to local governments.
6. WSDOT must be accountable to taxpayers to provide cost-effective stormwater facilities. WSDOT cannot infringe on the Legislature's authority to allocate gasoline tax funds to transportation programs and projects by agreeing to measures that significantly increase project costs.

1-1.5. Overview of Federal, State, and Local Regulations Related to Stormwater

Water pollution control was formally established as a federal concern when Congress passed the first Water Pollution Control Act in 1948. For many years, the emphasis was on control of point source pollution; typically, outfalls from industrial factories and municipal sewage treatment plants. Since the early 1980s, water pollution control efforts have broadened to address non-point sources of pollution. Pollution collected and carried by stormwater often originates from nonpoint sources, but may be collected, conveyed, and discharged as a point source.

Major amendments to the Federal Water Pollution Control Act (which has become known as the Clean Water Act) in 1987 addressed stormwater pollution by extending the National Pollutant Discharge Elimination System (NPDES) permit program to include stormwater discharges. Also in 1987, the Puget Sound Water Quality Authority (now the Puget Sound Action Team) issued the Puget Sound Water Quality Management Plan. This plan called for a Highway Runoff Program, which was subsequently developed in detail by Ecology and codified in WAC 173-270.

1-1.5.1. Phase I NPDES Municipal Stormwater General Permits

In 1995, Ecology prepared NPDES municipal separate storm sewer permits for several municipalities with populations greater than 100,000. The Phase I NPDES permittees included the cities of Seattle and Tacoma; the counties of Clark, King, Pierce, and Snohomish; and WSDOT.

The Phase I NPDES Municipal Stormwater General Permit (originally effective through the year 2000 and subsequently extended by Ecology pending reissuance of the Phase I municipal permit and issuance of the WSDOT municipal permit) requires WSDOT to implement a stormwater program within the Phase I jurisdictional areas, including minimum requirements and BMPs equal to those found in the *Stormwater Management Manual for the Puget Sound Basin* or equivalent. The stormwater management plan developed in accordance with this Phase I permit requires WSDOT to “reduce pollutants in discharges to the maximum extent practicable (MEP).” To attain future compliance with its revised NPDES permit, and to continue to meet the general standards of all known, available, and reasonable technology (AKART) and MEP, WSDOT must implement a stormwater program that includes minimum requirements and best management practices consistent with those found in the SMMWW and the SMMEW.

1-1.5.2. NPDES Construction Stormwater General Permit

Beginning in 1995, WSDOT construction projects were also required to comply with the Ecology NPDES requirements specific to construction activities. The threshold for a site disturbance area that typically triggered an NPDES Construction Stormwater General Permit was 5 acres. Some large WSDOT projects with particularly sensitive environmental

concerns are required to obtain individual NPDES construction stormwater permits from Ecology. NPDES construction stormwater permits require:

- Detailed documentation of temporary erosion and sediment control (TESC) measures.
- Implementation of TESC measures.
- Other pollution prevention and control measures.

Activities at sites such as the Washington State Ferries Eagle Harbor maintenance facility are covered under the NPDES Industrial Stormwater General Permit. Beginning in 1999, several fish species in Washington State were listed as threatened or endangered under the ESA, thus expanding the necessity for stormwater runoff control at WSDOT project sites in many parts of the state. The ESA requires that a biological evaluation be conducted to determine potential project impacts on threatened or endangered species, including impacts associated with stormwater. Stormwater management measures implemented at many WSDOT sites have been shaped by requirements necessary to avoid, minimize, or reduce potential impacts to threatened and endangered species under the ESA. The Section 7 Consultation process serves as the primary ESA compliance pathway for WSDOT projects.

1-1.5.3. Phase II NPDES Municipal Stormwater General Permits

Beginning in March 2003, the U.S. Environmental Protection Agency (U.S. EPA) extended the NPDES permit program (Phase II) for municipal separate storm sewer systems to encompass many more jurisdictions. Ecology's issuance of permits under Phase II of the NPDES program extended requirements for effective stormwater management to most of the state's urbanized areas. Also in 2003, the NPDES permit program lowered the threshold for construction projects that require general NPDES construction stormwater permits to 1 acre of ground disturbance; thus encompassing a much higher percentage of WSDOT projects. Ecology's reissuance of the NPDES Construction Stormwater General Permit incorporates additional regulations of the U.S. EPA's nationwide Phase II program and requires implementation of construction site BMPs in conformance with the SMMWW and SMMEW.

Additional state regulations applicable to stormwater include:

- Implementation of Total Maximum Daily Load (TMDL) plans by Ecology and local partners, resulting in limitations on pollutants in stormwater discharges. TMDLs are addressed in Section 303(d) of the Clean Water Act.
- Conditions of the underground injection control (UIC) program (WAC 173-218). The UIC program is administered by Ecology to implement provisions of the federal Safe Drinking Water Act. It applies to subsurface drainage facilities (such as drywells) that discharge water to the ground.
- Site-specific Section 401 (of the Clean Water Act) Water Quality Certifications issued by Ecology in relation to projects that require federal Section 404 permits for in-water work. Section 404 of the Clean Water Act

provides federal regulatory protection for wetlands and other waters of the United States.

- Conditions of aquatic lands use authorizations. The aquatic lands use authorization is administered by the Washington State Department of Natural Resources (DNR) and may apply to stormwater outfalls per RCW 79.90 through 79.96 and WAC 332-30.
- State surface water quality standards (WAC 173-201A).

In most instances, local stormwater management requirements will not override the requirements in this manual. RCW 47.01.260(1) grants WSDOT plenary power in planning, locating, designing, constructing, improving, repairing, operating, and maintaining state highways, including drainage facilities and channel changes necessary for the protection of such highways. This grant of authority means that, without express legislative direction, WSDOT is not subject to local ordinances in areas within WSDOT's purview, and attempts by local agencies to enforce such preempted ordinances are unconstitutional.

1-1.5.4. Local Requirements

With respect to all state highway right of way in the Puget Sound basin under WSDOT control, WSDOT must use the HRM to direct stormwater management for its existing and new facilities and rights of way, as addressed in WAC 173-270-030(1). Stated exceptions where more stringent stormwater management requirements may apply are addressed in WAC 173-270-030(3)(b) and (c).

- When a state highway is located in the jurisdiction of a local government that is required by Ecology to use more stringent standards to protect the quality of receiving waters, WSDOT will comply with the same standards to promote uniform stormwater management. The key emphasis here is that Ecology has to require the local government to use more stringent standards (such as via an existing TMDL) rather than the local jurisdiction simply doing so of its own accord.
- WSDOT will comply with standards identified in watershed action plans for WSDOT rights of way, as required by WAC 400-12-570. This is similar to the condition described above; however, its application is complicated by the fact that WAC 400-12-570 (*Action Plan Implementation*) was repealed on December 7, 1991.

Other instances where more stringent local stormwater standards can apply are projects subject to tribal government standards and to the stormwater management-related permit conditions associated with critical area ordinances (under the Growth Management Act) and shoreline master programs (under the Shoreline Management Act). In addition, WSDOT must comply with local jurisdiction stormwater standards when WSDOT elects, and is granted permission, to discharge stormwater runoff into a municipality's stormwater system.

Issuance of WSDOT's statewide municipal NPDES permit will further reduce the number of stormwater-related permits required by no longer regulating stormwater discharges under *Section 401 Water Quality Certification* and *Hydraulic Project Approval* permits.

This manual represents a set of tools and options that supports compliance with local, state, and federal regulations related to stormwater management. Incorporation of local and regional stormwater requirements into project design is further discussed in Sections 2-6 and 2-7.

1-2. The Importance of Stormwater Management

1-2.1. Background and Objectives

Land development can have a dramatic impact on the natural hydrologic cycle. In western Washington, land cover that once consisted primarily of mature forest has been replaced in many areas with impervious surfaces such as rooftops, parking areas, roadways, and manicured landscapes. Similar transitions have occurred in eastern Washington where prairies, pine forests, shrub-steppe landscapes, and channeled scablands have been replaced by farmland and urbanization. The creation of impervious surfaces has two main effects on the hydrologic cycle: a reduction in infiltration and an associated increase in surface runoff. Reducing land cover, mainly by tree removal, can also significantly increase runoff, even though pervious surfaces remain.

The creation of impervious surfaces increases both the volume of surface runoff and the peak rate of flow resulting from a storm event, leading to increased flooding rate, extent, and severity. Increasing impervious surfaces also decreases the time to peak discharge. The higher velocity and greater quantity of flow may cause streambank erosion and aquatic habitat destruction that could potentially result in geomorphological impacts. Sediment from cleared areas and eroded and unstable streambanks is deposited downstream, filling ponds, streambeds, and stormwater facilities. Construction projects with exposed and unstabilized soils, especially on slopes, can be significant sources of soil and sediment that adversely affect drainage systems and receiving waters.

Stormwater and snowmelt runoff function as the transport mechanisms for nonpoint sources of pollution, as well as for the atmospheric deposition of airborne pollutants. In addition to the hydrologic effects from runoff, land development significantly increases the amount of pollutants available for entrainment in stormwater and snowmelt runoff. Increased pollutant loadings resulting from human habitation and activity can result in the measurable degradation of receiving waters.

A more subtle impact of development on the hydrologic cycle is the reduction of infiltration. Infiltration of precipitation, stormwater, and snowmelt runoff recharges groundwater and produces interflow: the subsurface flow particularly common in many of the soils in

Washington State. Shallow groundwater is typically the source of summer base flows in streams, and it sustains water levels in some wetlands. Reduction in infiltration can dry up small streams and wetlands in the summer and, in turn, render aquatic systems uninhabitable during these times.

1-2.2. Impacts of Roadway Runoff

Runoff from roadways and associated facilities may contain suspended solids; oil and grease (hydrocarbons); and heavy metals such as lead, copper, and zinc. Many of the pollutants in roadway runoff are attributed to motorized vehicle operation. The wearing of brake linings, thrust bearings, engine crankshafts, and tires results in the deposition of numerous heavy metal particles on the roadway surface. The dripping of oil and other engine fluids deposits additional heavy metals, phosphorus, hydrocarbons, and other toxic organic compounds on the roadway surface. Atmospheric deposition of airborne pollutants via rain and snow events also contributes to the pollutant content on roadways, particularly in heavily urbanized areas. Litter, organic debris, and other materials that are common in roadway corridors also contribute to the pollutant loading in roadway runoff. The motor vehicle industry is engaged in various efforts to reduce the extent to which vehicles produce pollutants. These include the manufacture of brake pads with less copper content and engines powered by alternative energy sources, which may reduce pollutant loadings in roadway runoff in the future.

Transportation projects, which tend to be linear in nature, may encompass multiple drainage basins and impact multiple receiving waters. While the runoff discharged from highways and other parts of the transportation infrastructure represents only a portion of the runoff affecting nearby water bodies, it contributes to the cumulative degradation of those waters. The effects of stormwater runoff on receiving waters are typically a function of the proximity of development site discharges to the receiving water body and the size of the receiving water body relative to discharge volumes and flow rates. The impacts of stormwater runoff from state-owned rights of way vary widely, depending on surrounding land use, climate patterns, soil characteristics, receiving water characteristics, and other local factors.

The construction of roadway improvement projects also contributes to surface runoff contamination, due mainly to suspended solids associated with soil erosion. Construction activities can also result in stormwater and nearby surface waters being contaminated with oil, heavy metals, and other pollutants resulting from vehicle operations and maintenance; runoff from areas where solvents, paints, and other liquid materials are used and stored; leaching of asphalt emulsion and concrete slurry; and a variety of other sources. Those impacts can be severe and long-lasting if appropriate actions are not taken to control construction site runoff quality.

1-2.3. Management of Runoff From Transportation Projects

The key to controlling problems created by stormwater is the application of best management practices (BMPs). BMPs are defined as physical, structural, and managerial practices that,

when used individually or in combination, prevent or reduce pollution of water and attenuate peak flows and volumes. BMPs targeting the types of problems discussed above are typically categorized as *temporary* or *permanent*. Temporary BMPs are typically used only during the construction phase of a project. Permanent BMPs are used to control and treat runoff throughout operation of the highway, park-and-ride lots, rest areas, ferry terminals, or other transportation project sites. Some BMPs, such as detention ponds, may function in both temporary and permanent BMP capacities.

Temporary BMPs are designed to prevent the introduction of pollutants into runoff for the duration of the construction project and are concurrent with construction of the permanent BMPs. Common examples of temporary BMPs include mulching of bare ground, silt fencing, and spill control and containment. Permanent runoff treatment BMPs include facilities that remove pollutants from runoff by simple gravity settling of particulate matter and by filtration, biological uptake, and soil adsorption (typical examples include wet ponds and vegetated swales). Flow control BMPs reduce the peak rate of runoff during a storm event by storing the flow and releasing it at a slower rate, thus protecting stream ecosystems from excessive erosion (typical examples are detention ponds and dry vaults). Permanent BMPs are used to treat highway runoff for the design life of the project site.

Stormwater problems can be grouped into two categories: (1) impacts associated with existing impervious areas, and (2) impacts arising from new impervious areas if no stormwater controls are used. New projects that must comply with this manual are required to provide stormwater management for the new impervious surfaces.

Project designers should keep in mind that the ultimate goal is to provide practicable stormwater management for runoff from the existing impervious surfaces and protect the beneficial uses of receiving waters. Existing highway sections that have no stormwater treatment or flow control, or where treatment or flow control is substandard, may eventually be retrofitted in accordance with WSDOT's stormwater retrofit program. If it is cost-effective to include a BMP to address the entire project site, even though only a portion of the facility is undergoing expansion or redevelopment, the BMP should be designed and constructed to address the larger area. Guidelines for determining whether it is cost-effective to provide stormwater management beyond what is required are in Section 3-4.

In some cases, it may not be practicable to provide treatment or flow control for runoff from project-site areas, due to various constraints such as site limitations, costs, or other obstacles. If on-site mitigation is not feasible, opportunities that use this manual's off-site treatment options must be identified. Sections 2-7.3 and 2-7.4 present a process for analyzing off-site treatment options. WSDOT will continue to develop, pursue, and expand off-site options. However, these options are currently constrained to the "in-kind" variety, as Ecology has stated it will not authorize the use of "out-of-kind" mitigation options.

1-3. Organization of This Manual

The *Highway Runoff Manual* (HRM) is divided into six chapters. Chapter 1 provides background information on the development of the manual and an overview of the stormwater problems associated with highways and other parts of the transportation infrastructure.

Chapter 2 provides an overview of the WSDOT project design process and how the stormwater/drainage design elements should be integrated into that process. Guidelines are provided for gathering predesign data and analyzing design alternatives.

- Appendix 2A presents a method to assist in determining when site-specific factors could make constructing stormwater management facilities within or adjacent to the highway right of way infeasible.

Chapter 3 describes the minimum requirements that apply to the planning and design of stormwater facilities and best management practices. Guidelines are provided to determine which of the nine minimum requirements must be met for a given transportation project. The purpose and the applicability of the minimum requirements are described. Guidelines are also provided for assessing (1) whether project-driven stormwater retrofit obligations can be met off-site by retrofitting an equivalent area of state highway in targeted environmental priority locations, and (2) whether it is cost-effective to provide stormwater management retrofits beyond what is called for under these requirements.

Chapter 4 provides a description of the different hydrologic analysis methods that must be used to design stormwater runoff treatment and flow control facilities. This chapter also provides a detailed explanation of the analysis methods used as well as the supporting data and assumptions needed to complete the design.

- Appendix 4A contains the websites and web links related to Chapter 4.
- Appendix 4B contains the TR55 Curve Number Tables.
- Appendix 4C covers eastern Washington design storm events.

Chapter 5 guides the project designer through the selection of permanent stormwater treatment, infiltration, and flow control BMPs and their design processes. It includes a process for BMP selection in both western and eastern Washington. Criteria for the use of emerging technologies and discussions about operation and maintenance are included. Detailed design criteria for each permanent BMP are included in Section 5-4.

Chapter 6 guides the project designer through the process of selecting and designing temporary construction-related BMPs. It includes criteria for selecting appropriate erosion and sediment control (ESC), as well as spill prevention, control, and countermeasures (SPCC) BMPs (including operation and maintenance considerations). Chapter 6 also provides guidelines on water quality monitoring for projects required to monitor runoff quality and receiving water effects during construction.

- Appendix 6A includes the design criteria for each temporary BMP.

1-4. How to Use This Manual

The designer should follow the guidelines for integrating the planning and design of stormwater-related project elements into the context of WSDOT's project development process prior to using the guidelines in Chapter 3 to determine which minimum requirements must be satisfied for a specific project. In most instances, this process will spur the need to design construction and postconstruction BMPs according to the criteria provided in Chapters 4, 5, and 6.

Most projects lend themselves to relatively straightforward application of one or more of the BMP options presented in this manual. However, many WSDOT sites are not conducive to easy installation of any BMPs. When these types of problems arise, contact the following for assistance:

- **BMP Selection** – Region environmental or hydraulics staff, then the Hydraulics Section staff or the Stormwater & Watersheds Program staff at the HQ Environmental Services Office (ESO).
- **Outfall Inventory/Field Screening Results, Stormwater Retrofit Priorities, NPDES Municipal Stormwater Permit, and Water Quality Sampling** – Staff in the HQ ESO, Stormwater & Watersheds Program.
- **Spill Control, Containment, and Countermeasure Activities** – Region environmental staff, then staff in the HQ ESO, Hazardous Materials Program.
- **Temporary Erosion and Sediment Control Plans and Construction Site BMPs** – Region environmental staff, then staff in the HQ ESO, Stormwater & Watersheds Program.
- **Vegetation Management** – Region and HQ Landscape Architects, then HQ Highway Maintenance staff.
- **Roadway Maintenance Practices** – Region maintenance staff, then HQ Highway Maintenance environmental staff.
- **Emerging BMPs** – Region environmental staff and the HQ ESO, Stormwater & Watersheds Program staff.

For information about the HRM-related training curriculum, see the HRM Resource Web Page:  www.wsdot.wa.gov/Environment/WaterQuality/Runoff/HighwayRunoffManual.htm

CHAPTER 2

Stormwater Planning and Design Integration

Chapter 2. Table of Contents

Chapter 2.	Stormwater Planning and Design Integration	2-1
2-1	Introduction	2-1
2-2	Stormwater Management Objectives	2-1
2-3	Project Development Overview	2-1
2-3.1	Development Team	2-3
2-3.2	Site Assessment.....	2-5
2-3.2.1	Information Sources	2-6
2-3.2.2	Geotechnical Evaluations	2-7
2-3.2.3	Right of Way	2-8
2-3.2.4	Utilities	2-8
2-3.3	Maintenance Review	2-8
2-3.4	Documentation	2-9
2-3.4.1	Stormwater Scoping Package	2-9
2-3.4.2	Project Summary	2-10
2-3.4.3	Environmental Documentation.....	2-10
2-3.4.4	Hydraulic Report	2-11
2-3.4.5	Construction Planning	2-11
2-3.4.6	Contract Plan Sheets.....	2-12
2-3.4.7	Plans, Specifications, and Estimates (PS&E).....	2-12
2-3.4.8	Underground Injection Control Wells	2-12
2-4	Developer Projects	2-12
2-5	Stormwater Facility Design Approach	2-13
2-5.1	Context Sensitive Design	2-13
2-5.2	Stormwater Facility Design Strategy	2-13
2-6	Special Design Considerations.....	2-14
2-6.1	Critical and Sensitive Areas	2-14
2-6.1.1	Wetlands	2-14
2-6.1.2	Floodplains	2-15
2-6.1.3	Aquifers and Wellhead Protection Areas	2-15
2-6.1.4	Streams and Riparian Areas	2-17
2-6.2	Endangered Species	2-17
2-6.3	Contaminated and Hazardous Waste Sites.....	2-17
2-6.4	Airports	2-18
2-6.5	Bridges	2-18
2-6.6	Ferry Terminals.....	2-19
2-6.7	Maintenance Yards, Park-and-Ride Lots, and Rest Areas.....	2-19
2-7	How Stormwater Management Applies to a Project	2-19
2-7.1	HRM Minimum Requirements and Exemptions	2-19
2-7.2	Local Requirements	2-19
2-7.3	Watershed and Basin Plans	2-20
2-7.3.1	Watershed-Based Approach	2-21

2-7.4 Engineering and Economic Feasibility 2-21
2-7.5 Stormwater Retrofit..... 2-22

Appendix 2A. Engineering and Economic Feasibility Evaluation

List of Tables

Table 2-1 Stormwater planning and design in the project development process. 2-2
Table 2-2 Key contacts for development of project stormwater strategy..... 2-3
Table 2-3 Stormwater-related information needed for the Project Summary. 2-11

Chapter 2. Stormwater Planning and Design Integration

2-1 Introduction

This chapter provides guidelines for integrating the planning and design of stormwater-related project elements into the context of the Washington State Department of Transportation (WSDOT) project development process. How the process applies to a specific project depends on the type, size, and complexity of the project and individual WSDOT regional business practices.

2-2 Stormwater Management Objectives

Originally, the only function of highway stormwater management was to maintain safe driving conditions using engineering techniques designed to prevent stormwater from ponding on road surfaces. While maintaining safe driving conditions continues to be essential for any functional highway drainage system, WSDOT also acknowledges the state's vital interest in protecting and preserving natural resources and other environmental assets, as well as its citizens' health and safety. These interests have become integrated with other vital interests entrusted to the department, including the cost-effective delivery and operation of transportation systems and services that meet public needs. Thus stormwater management for WSDOT transportation facilities has two main objectives: (1) protect the functions of the transportation facility, and (2) protect ecosystem functions and the beneficial uses of receiving waters.

2-3 Project Development Overview

The integration of stormwater planning and design into WSDOT's project development process is shown in Table 2-1. While the process consists of the distinct phases described below, in practice the phases actually overlap and some design modifications may occur during the *Construction phase*.

- The initial phase of project development entails creation of the project scope (referred to as scoping). The project *Scoping and Programming phase* consists of determining a project description, schedule, and cost estimate. During the project scoping phase, Project Summary documents are produced and used to program the project. The environmental section of the Project Summary establishes the initial environmental classification and level of documentation for the project.
- After the project is programmed, it is further developed through the *Design and Environmental Review phase*. During this phase, much of the design work and environmental analysis and documentation requirements for a

project are completed and work on permit applications often begins. A Design Documentation Package (DDP) that compiles the project’s design considerations and conclusions is also produced during this phase. Once the DDP is reviewed and approved, it becomes the project design.

- The process continues through the development of project environmental permits, plans, specifications, and estimates (the *Environmental Permitting and PS&E phase*), which leads to production of contract documents for construction. Region or Headquarters environmental staff should be consulted at each stage of the project design to review the permits and approvals that may be required. By following the *Highway Runoff Manual* minimum requirements (see Chapter 3) and selecting BMPs (see Chapter 5 and Appendix 6A) that are suggested for the specific highway setting, the design team plays a critical role in project development by avoiding costly design changes and delays in obtaining permits and keeping the project in compliance during construction, operation, and maintenance of the system.

Table 2-1. Stormwater planning and design in the project development process.

<u>Scoping → and Programming</u> ↓	<u>Design Approval/ → Environmental Documentation</u> ↓	<u>Environmental Permitting and PS&E</u> ↓
<u>Preliminary identification of water quality and hydrologic impacts and potential mitigation BMPs</u> ↓	<u>Formal documentation of stormwater-related environmental impacts</u> Selection of stormwater mitigation BMPs: type, size, and location ↓	Final design of stormwater BMPs: working plans <u>Obtain environmental permits</u> ↓
Project Summary supported by design file documentation: <ul style="list-style-type: none"> ▪ Stormwater scoping package ▪ Environmental Review Summary ↓	Design report <u>and environmental permit applications</u> supported by design file documentation: <ul style="list-style-type: none"> ▪ Required environmental documentation (such as <u>SEPA, NEPA, and ESA Biological Assessments</u>) ▪ <u>Hydraulic Report</u> ↓	Plans, Specifications, and Estimates package: <ul style="list-style-type: none"> ▪ TESC plan ▪ Provisions for SPCC plan ▪ Stormwater-related plans; General and Special Provisions ↓
BMP cost allocation ↓	Preliminary BMP cost estimate <u>Environmental commitments that arise from the DDP (such as use of experimental BMPs triggering costly and lengthy monitoring requirements through the demonstrative approach)</u> ↓	BMP cost estimate <u>Environmental commitments become permit requirements</u>

The level of effort invested during each phase of development and the extent to which the phases overlap for a specific project varies depending on the type, size, and complexity of that project. The project's design may also undergo modifications during the construction process. For further description and instruction related to the *Scoping and Programming, Design and Environmental Review, Environmental Permitting, and PS&E* phases, refer to the *Environmental Procedures Manual* and the *Design Manual*.

2-3.1 Development Team

Assessment and documentation of stormwater impacts and mitigation measures begin during project scoping. The scoping and design teams must involve appropriate participants (listed in alphabetical order in Table 2-2) as part of the scoping process. Project type, size, and complexity are key factors in determining who must be consulted for development of the stormwater strategy for a project.

Table 2-2. Key contacts for development of project stormwater strategy.

Contact	Roles	Activities
Air and Noise	Performs air quality and noise analyses.	Conducts air and noise testing; determines wall locations.
Biologist	Performs biological analyses.	Delineates wetlands; prepares wetland reports, biological assessments, and mitigation recommendations.
Bridge and Structures Office	Structural design.	Assesses condition of existing structures; designs new structures; prepares PS&E for structures; coordinates backwater studies and pier placement.
Construction Offices	Manages project construction.	Contributes to design considerations; provides constructibility reviews.
Consultant Liaison	Consultant administration.	Issues request for proposal; assists in development of scopes of work; selects consultant; manages contract.
Developer Services	Coordinates development activity.	Provides information and contacts for other development activity in the area.
Geotechnical and Materials Laboratory	Determines geotechnical requirements; obtains data; provides analyses.	Provides scope and cost estimate of geotechnical work; reviews existing records and maps; performs soil borings; installs piezometers; conducts pH and resistivity testing. Assesses sources of materials and makes surfacing recommendations.
Local Programs Office and Local Agencies	Various	Provides funding and design criteria; develops maintenance agreements.
Maintenance	Provides recommendations.	Provides information on existing conditions; gives input on maintenance requirements of completed project.
Planning Office	Determines future plans for route location.	Determines route development plans; develops proposals.
Plans Office/Plan Review Office	Ensures compliance with plan standards.	Assists with preparation of Special Provisions and plans; provides final plan reviews.

Contact	Roles	Activities
Program Management (including program development)	Manages current biennial program; develops future biennial programs.	Manages set-up design and construction funding and assists with below-the-line costs; manages project definition process.
Project Design Office	Project management.	Participates in all aspects of project management and design.
Railroads	Manages design conflicts.	Identifies facilities, relocation requirements, and design considerations.
Real Estate Services	Real estate management.	Determines ownership; estimates property costs; procures rights of way, easements, rights of entry, and access management.
Regional Transit Authorities	Various	Coordinates regional issues, basin plans, construction projects, and route development.
Region and HQ Hydraulics	Provides assistance with hydraulic elements of design; provides approval or concurrence.	Determines hydraulic requirements; manages design, review, and approval of hydraulic and TESC design elements; assists with construction monitoring.
Region Environmental/HQ Environmental Services	Performs analyses of environmental impacts and alternatives; assures compliance with environmental laws and regulations.	Prepares environmental (NEPA/SEPA) documents; coordinates with resource and permitting agencies; assists with public involvement; obtains environmental permits.
Resource Agency (various)	Reviews reports; issues permits.	Provides endangered species list; approves biological assessments; issues permits that establish conditions for design and construction.
Right of Way Research and HQ Photogrammetry	Maintains as-built and right of way/access records.	Provides information regarding project location for inclusion in plans; provides aerial photos, survey, and photogrammetry development.
Roadside and Site Development Section	Provides landscape design plans.	Prepares landscaping plans, specifications, and estimates, including planting and irrigation work; inspects construction; manages plant establishment period until sign-off by regulators.
Safety Office	Applies safety standards.	Assists with designs and provisions for stormwater features to meet regulations and codes.
State Design Engineer	Approves design.	Reviews and approves overall design.
Survey	Collects survey information.	Compiles field data; performs surveys; stakes right of way; verifies existing conditions.
Traffic	Traffic analysis and design.	Collects traffic data; develops traffic models; reviews channelization plans/work zone traffic control plans.
Tribal Organizations	Various	May provide funding and comments on project.
Utilities	Manages existing and new utilities.	Determines utility requirements; prepares franchise inventory listing; reviews clear zone inventory; obtains utility as-built plans for inclusion on plan sheets; prepares relocation plan and utility agreements.

2-3.2 Site Assessment

Stormwater facility design is a major element for many projects, and it requires significant advance data gathering and assessment to identify alternatives and develop accurate schedules and cost estimates. Data are needed to assess the project site in order to (1) determine project alignment alternatives, (2) assess impacts, (3) determine minimum requirements, and (4) develop conceptual stormwater management alternatives.

Characterizing the site and adjacent areas allows for a determination of the limiting factors controlling local hydrology. These limiting factors can then become the focus of the project's stormwater management strategies.

A three-dimensional picture of site hydrology will emerge during the site assessment. This picture will include natural and altered flow paths to the site from upstream areas and from the site to downstream areas. Natural drainage must be preserved (see Minimum Requirement 4, Section 3-3.4). The design team must identify all off-site flows coming to the site, including streams, seeps, and stormwater discharges. The transportation facility must allow for passage of all off-site flows; however, every effort should be made to keep off-site flows separate (via bypass) from the highway runoff. This may not be possible for flows that are currently permitted to discharge to WSDOT conveyance and treatment facilities.

Runoff from WSDOT rights of way must not adversely affect downstream receiving waters and properties. Existing drainage impacts on downstream waters and properties must be identified during scoping and must be either corrected as part of the project or recommended for a later retrofit. Drainage impacts are identified using multiple sources of information (see Section 2-3.2.1) and site visits during storms. Section 4-7 in the *Hydraulics Manual* provides guidelines on performing and documenting a downstream analysis. The preliminary downstream analysis is used for scoping purposes; however, a more detailed analysis may be needed during the project design phase. The final downstream analysis is included in the Hydraulic Report.

The scoping phase is the time to begin identifying natural areas within or adjacent to the project boundary that can be conserved. Conserving these areas helps to minimize project impacts. Some of these areas may be used as part of the project's stormwater management approach if they are appropriate areas for dispersion and infiltration. (See Chapters 4 and 5 for information regarding dispersion and infiltration.)

Conservation areas and their functions must be permanently protected under conservation easements or other locally acceptable means. If the conservation area falls within the right of way, it needs to be appropriately labeled on the right of way plan. If the conservation area is outside the right of way, then WSDOT needs to purchase a conservation easement or obtain another similar real estate protection instrument.

2-3.2.1 Information Sources

As a starting point, the following data and resources are generally necessary for site assessments:

- Project vicinity map and site map
- Land cover types and areas (aerial photographs)
- Topography (USGS quadrangle maps and other survey maps)
- Watershed or drainage basin boundaries
- Receiving waters
- Wetlands
- Stream flow data
- Ditches and open-channel drainage
- Enclosed drainage
- Floodplains
- Utilities
- Total maximum daily loads (TMDLs)
- Water cleanup plans
- Clean Water Act Section 303(d) list of impaired waters
- Drainage patterns and drainage areas
- Basin plan data (basin-specific needs)
- Soil types, depth, and slope (Natural Resources Conservation Service soil surveys)
- Existing stormwater outfalls (outfall inventory and site reconnaissance)
- Land use types and associated pollutants
- Groundwater data (including depth to seasonal high water table)
- Soil infiltration rates
- Vegetation surveys
- Land surveys
- Hazardous materials or wastes
- Average daily traffic (ADT)

- Roadway geometry (profiles/superelevations)
- Geotechnical evaluation (see Section 2-3.2.2)

The contacts in Table 2-2 can help in collecting this information. In addition, WSDOT's *GIS Workbench* (an ArcView geographic information system tool to provide staff with access to comprehensive, current, and detailed environmental and natural resource management data) can be used to gather some of these data and can provide maps to help with project assessment, selection of stormwater management alternatives, and maintenance applications.

2-3.2.2 Geotechnical Evaluations

Understanding the soils, geology, geologic hazards, and groundwater conditions at the project site is essential to optimizing stormwater design for a project. Contact the Region Materials Engineer (RME) and staff from the HQ Geotechnical Services Division as early as possible in the scoping phase for inclusion on the scoping and design team.

Infiltration is the preferred method for flow control of stormwater runoff. Chapters 4 and 5 provide direction on how to apply optimal infiltration for stormwater management on transportation projects. However, the extent to which infiltration can be used needs to be assessed during the scoping phase because of its direct impact on stormwater alternatives and costs. The degree to which runoff can be infiltrated depends on the project location and context. Limiting factors include soil characteristics, depth to groundwater, and designated aquifer protection areas.

The RME evaluates the geotechnical feasibility of stormwater facilities that may be needed for the project. With assistance from the HQ Geotechnical Engineer, as needed, the RME gathers all available geotechnical data pertinent to the assessment of the geotechnical feasibility of the proposed stormwater facilities. Some subsurface exploration may be required at this stage, depending on the adequacy of the geotechnical data available to assess feasibility. Refer to the *Design Manual* for additional details.

The scoping office develops the stormwater facility conceptual design using input from the RME and the HQ Geotechnical Engineer. Based on this design and investigation effort, fatal flaws in the proposed stormwater plan are identified as well as potential design and construction problems that could affect project costs or the project schedule. Critical issues to be considered include the following:

- Depth to water table (including any seasonal variations)
- Presence of soft or otherwise unstable soils
- Presence in soils of shallow bedrock or boulders that could adversely affect constructibility
- Presence of existing adjacent facilities that could be adversely affected by construction of the stormwater facilities

- Presence of geologic hazards such as earthquake faults, abandoned mines, landslides, steep slopes, or rockfall
- Adequacy of drainage gradient to ensure functionality of the system
- Potential effects of the proposed facilities on future corridor needs
- Maintainability of the proposed facilities
- Potential impacts on adjacent wetlands and other environmentally sensitive areas
- Presence of hazardous materials in the area
- Whether or not the proposed stormwater plan will meet the requirements of resource agencies
- Infiltration capacity (infiltration and percolation rates for project sites)

To characterize the seasonal variation of the groundwater table, it may be desirable to install piezometers at potential infiltration sites during scoping. One year of monitoring is desirable. At a minimum, one full rainy season is necessary to acquire the data needed to make a determination of site suitability.

2-3.2.3 Right of Way

Once the stormwater requirements for the project are understood, the general hydrologic site characteristics are known (including approximate groundwater table elevations), and the stormwater design alternatives are determined, the area necessary for stormwater facilities can be estimated. Refer to Chapters 4 and 5 to estimate the required area for each facility. Examine the proposed layout of the project, and determine the most suitable sites available to locate the stormwater facilities. Determine where facilities are proposed outside existing right of way and establish estimates for right of way acquisition areas and costs.

2-3.2.4 Utilities

The project design office must contact the Region Utilities Office to obtain information about whether existing utilities have franchises or easements within the project limits. Whenever proposed stormwater facilities conflict with an existing utility's right of way and facilities, a utility agreement is required. WSDOT may be responsible for the relocation costs, the utility owner may be responsible for the costs, or the costs may be shared. Further information about utility elements is available in the *Utilities Manual*.

2-3.3 Maintenance Review

Once a list of permanent stormwater BMPs is determined based on the site assessment, the designer must contact the Region Maintenance Office to discuss treatment options available

for use. Overall maintenance costs must be considered when selecting BMPs. The project design office must consult with the region maintenance staff regarding the proposed drainage alternatives and evaluate maintenance needs, including personnel, equipment, and long-term costs through the BMP's expected life cycle. Review the general maintenance requirements in Section 5-3.7.1 and the maintenance guidelines in Section 5.5. Maintenance concurrence must be obtained prior to the final selection of the treatment BMP and documented in the Hydraulic Report.

2-3.4 Documentation

Thorough documentation of stormwater-related environmental impacts and tracking of stormwater design commitments is a required element of the State Environmental Policy Act (SEPA) and National Environmental Policy Act (NEPA), as well as other environmental laws, and environmental permit applications. To aid in the accurate exchange of stormwater information from the design team to workgroups preparing environmental documentation and permit applications, a Stormwater Design NEPA/SEPA Documentation Checklist and accompanying Stormwater Design Documentation Spreadsheet should be prepared for each project. The Checklist and Spreadsheet are available separately at:

www.wsdot.wa.gov/Environment/WaterQuality/Runoff/HighwayRunoffManual.htm.

For a general list of documents required to be preserved in the Design Documentation Package and the Project File, see the Design Documentation Checklist at:

www.wsdot.wa.gov/design/projectdev/

2-3.4.1 Stormwater Scoping Package

Stormwater documentation during the scoping phase of project development is referred to here as the *stormwater scoping package*. This package contains the information used to preliminarily determine project stormwater impacts and the initial selection of stormwater BMPs. It is the source of stormwater information needed to complete the Project Summary documents. This package must include a brief summary report that contains the following:

- Identification of the project program
- Brief project description
- Synopsis of data gathered during the site assessment
- Basin and subbasin identification
- Threshold discharge area delineations indicating flow paths and outfalls to receiving waters
- Area determinations
- Applicable minimum requirements

- Other applicable regulatory requirements related to stormwater (such as Endangered Species Act requirements)
- Design criteria required for flow control and runoff treatment
- Known problems and commitments
- Retrofit recommendations
- Design alternatives and assumptions for flow control and runoff treatment
- Cost estimates

The stormwater scoping package is critical to the efficient continuation of project development and must be retained and easily retrievable. Once the project is programmed and assigned to a project office, the file and report become the starting point for the design phase. The stormwater scoping package must be kept and stored by the Region Program Management Office or scoping office. The package must remain with the overall project scoping file to ensure the project office to which the project is assigned for design receives the preliminary stormwater information.

2-3.4.2 Project Summary

As described in Section 2-3, the product of scoping is the *Project Summary*, which is developed and approved before the project is funded for design and construction and consists of the *Project Definition*, *Environmental Review Summary*, and *Design Decisions Summary*. All of these documents require stormwater-related information, as outlined in Table 2-3. The Project Summary is prepared to document results of the scoping process and define the overall scope of the proposed solution in terms of the work and material involved. This includes the level of environmental documentation and extent of permitting work and mitigation, as well as cost estimate and performance outcome and benefit/cost ratio for the project. This documentation is also used to link the project to the Washington State Highway System Plan and the Capital Improvement and Preservation Program (CIPP).

2-3.4.3 Environmental Documentation

For any project funded by the Legislature, environmental documentation begins after the Project Summary is approved and ends with the approval of any documents that must be completed for compliance with SEPA and NEPA, as well as other environmental laws, including, but not limited to, the Endangered Species Act and Section 6(f) of the Land and Water Conservation Fund Act. Environmental documents are drafted after analyzing environmental issues, comparing alternatives, developing mitigation measures, consulting with resource agencies about required permits, and making a determination about the significance of any remaining unmitigated environmental impacts. Much of the stormwater-related design information needed for permit applications can be obtained from the Project Summary and environmental documentation. Refer to the *Environmental Procedures Manual* for specific instructions on preparing environmental documents.

Table 2-3. Stormwater-related information needed for the Project Summary.

Project Definition (PD)	<ul style="list-style-type: none"> ▪ Cost estimate and variance for preliminary engineering, right of way, and construction ▪ Right of way needs for stormwater facilities ▪ Preliminary environmental review: required environmental documentation, permits, and environmental commitments ▪ Design decisions regarding stormwater ▪ Public input regarding stormwater ▪ Project commitments for stormwater made to and by others ▪ Potential impacts of stormwater facilities on utilities ▪ Specialized workforce expertise required for geotechnical, biological, geomorphic, and other evaluations ▪ Other stormwater-related issues
Environmental Review Summary (ERS) and Environmental Classification Summary (ECS)	<ul style="list-style-type: none"> ▪ Required permits and approvals related to stormwater ▪ Critical or sensitive areas as designated by Growth Management Act ordinances ▪ Floodplains or floodways within (or affecting) the project site ▪ Rivers and streams: crossing structures and types ▪ Water quality/stormwater: impacts and mitigation ▪ Previous environmental commitments made in project <u>site</u> related to stormwater ▪ Long-term maintenance commitments related to stormwater and necessary for project
Design Decisions Summary (DDS)	<ul style="list-style-type: none"> ▪ Roadway geometrics data affected by stormwater facilities ▪ Roadside character classification and treatment level: effect on stormwater facility design (forest, open, rural, semiurban, urban) ▪ Hydraulic decisions regarding stormwater facilities

2-3.4.4 Hydraulic Report

The Hydraulic Report is intended to serve as a complete document record containing the engineering justification for all drainage modifications that occur as a result of project construction, including documentation of the analysis and design for the postconstruction stormwater management system. Refer to the *Hydraulics Manual* for additional details.

2-3.4.5 Construction Planning

During the design phase, key stormwater documents are produced to meet stormwater site planning requirements associated with Minimum Requirement 1 (see Section 3-3-1).

All projects require spill prevention, control, and countermeasures (SPCC) plans, which are prepared by the contractor after the project contract is awarded. The WSDOT Hazardous Materials Program (www.wsdot.wa.gov/environment/hazmat/default.htm) and Section

1-07.15(1) in the *Standard Specifications for Road, Bridge, and Municipal Construction (Standard Specifications)* provide more information regarding SPCC plan expectations. To ensure plan implementation, develop provisions of the SPCC plan during the PS&E phase.

For soil-disturbing projects, WSDOT must also prepare temporary erosion and sediment control (TESC) plans (see Chapter 6).

2-3.4.6 Contract Plan Sheets

Infiltration, dispersion, and conservation areas, as well as other drainage and environmental elements, need to be identified on the contract plan sheet. Development of the contract plan sheets is defined in Division 4 of the *Plans Preparation Manual*.

2-3.4.7 Plans, Specifications, and Estimates (PS&E)

For the PS&E phase of a project, a set of Plans, Specifications, and Estimates is prepared. These documents translate the stormwater management elements of the design into a contract document format for project advertisement, bidding, award, and construction.

2-3.4.8 Underground Injection Control Wells

Drywells and infiltration trenches that contain perforated pipe are considered injection wells and require registration per the Washington State Department of Ecology's (Ecology's) Underground Injection Control (UIC) Program. Registration information is available at:
☞ www.ecy.wa.gov/programs/wq/grndwtr/uic/registration/reg_info.html

For further guidelines, consult region environmental staff or HQ Environmental Services Office staff.

2-4 Developer Projects

WSDOT must provide for the passage of existing off-site flows through its right of way to maintain natural drainage paths. If a private developer's project discharges off-site flow to WSDOT right of way, the developer needs to comply with state and local requirements, assuming all costs and liabilities associated with the design, construction, maintenance, and operation of the developer's stormwater management facilities. The developer must also demonstrate that WSDOT conveyance systems have adequate capacity to convey the developer's flows per *Hydraulics Manual* conveyance design standards. WSDOT will not concur with designs or allow discharges that do not comply with these requirements.

WSDOT requires discharge water be managed, at a minimum, in accordance with the provisions of the *Highway Runoff Manual*, Ecology stormwater management manuals, or an Ecology-approved local equivalent manual used by the local government with primary jurisdiction over the project.

For details regarding the WSDOT requirements and the process for review and concurrence of private project drainage design, refer to the *Development Services Manual* and the *Utilities Manual*.

2-5 Stormwater Facility Design Approach

2-5.1 Context Sensitive Design

It is important to recognize the watershed context of a project to understand how transportation facilities, in combination with other development, can affect the natural hydrology of watersheds and the water quality of receiving waters. This understanding can guide the planner and designer in choosing stormwater management solutions that more successfully achieve the objective of protecting Washington's ecosystems.

Context sensitive design (CSD), also known as *context sensitive solutions* and *thinking beyond the pavement*, is an approach to transportation planning that broadens the focus of the project development process to look beyond the basic transportation issues and develop projects that are integrated with the unique context(s) within the project setting. This approach considers the elements of mobility, safety, environment, community, and aesthetics from the beginning to the end of the project development process. The CSD also involves a collaborative project development process that obligates participants to understand the impacts and trade-offs associated with project decisions. Further discussion of and guidance on the context sensitive design/context sensitive solutions approach can be found at:

www.wsdot.wa.gov/biz/csd/

2-5.2 Stormwater Facility Design Strategy

Stormwater management facilities (runoff treatment and flow control) can be utilized to mitigate both the hydrologic impacts and the water quality impacts of a development project by applying the following fundamental strategy:

Maintain the preproject¹ hydrologic and water quality functions of the project site as it undergoes development.

This strategy is accomplished through the following steps:

- Step 1** Avoid and minimize impacts on hydrology and water quality.
- Step 2** Compensate for altered hydrology and water quality by mimicking natural processes.

¹ The term *preproject* refers to the actual conditions of the project site before the project is built.

Step 3 Compensate for altered hydrology and water quality by using end-of-pipe solutions.

Steps 1 and 2 can be achieved by minimizing impervious cover; conserving or restoring natural areas; mimicking natural drainage patterns (for example, using sheet flow, dispersion, infiltration, or open channels); disconnecting drainage structures to avoid concentrating runoff; and using many small redundant facilities to treat, detain, and infiltrate stormwater. This approach to site design reduces reliance on the use of structural management techniques. Step 3 refers to the use of traditional engineering structural approaches (for example, detention ponds) to the extent that Steps 1 and 2 are not feasible.

The methods listed for achieving Steps 1 and 2 above are commonly referred to as low-impact development (LID) approaches. By using the project site's terrain, vegetation, and soil features to promote infiltration, the landscape can retain more of its natural hydrologic function. Low-impact development methods will not be feasible in all project settings, depending on the physical characteristics of the site, the adjacent development, and the availability and cost of additional right of way (if needed). However, the designer must always investigate the feasibility of using low-impact development methods. Low-impact development methods require understanding of soil characteristics, infiltration rates, water tables, native vegetation, and other site features. For this reason, it is important to gain the participation of design support services and others from the beginning through the end of the project development process.

2-6 Special Design Considerations

2-6.1 Critical and Sensitive Areas

The Washington Growth Management Act (RCW 36.70A), combined with Article 11 of the Washington State Constitution, requires local jurisdictions to adopt ordinances that classify, designate, and regulate land use in order to protect *critical areas*. Critical areas are defined as wetlands, floodplains, aquifer recharge areas, geologically hazardous areas, and those areas necessary for fish and wildlife conservation.

2-6.1.1 Wetlands

Altering land cover and natural drainage patterns may increase or decrease stormwater input into surrounding wetlands. Land use changes and stormwater management practices usually alter hydrology within a watershed. Hydrologic changes have more immediate and greater effects on the composition of vegetation and amphibian communities than do other environmental changes, including water quality degradation.

Wetland ecosystems can be highly effective managers of stormwater runoff; they can remove pollutants and also attenuate flows and recharge groundwater. Minimum Requirement 7 (see Section 3-3.7) addresses wetland protection. While natural wetlands for the most part may

not be used as pollution control facilities in place of runoff treatment BMPs, Ecology's SMMEW allows the use of lower-quality wetlands as runoff treatment BMPs if requirements for hydrologic modification are met. For detailed guidance on this issue for eastern Washington projects, refer to *Use of Existing Wetlands to Provide Runoff Treatment* (Section 2.2.5, page 2-26) and *Application to Wetlands and Lakes* (Section 2.2.6, page 2-33) in Ecology's SMMEW and the *Eastern Washington Wetland Rating Form* at:

☞ www.wsdot.wa.gov/NR/rdonlyres/41520679-F96D-47A9-9B70-3EE8BBEC391F/0/WetlandRatingForm_EasternWA.doc

For western Washington projects that may potentially alter the wetland hydroperiod, refer to *Guide Sheet 2B* in Appendix I-D of Ecology's SMMWW to review the recommended allowable limits for altering the hydroperiod of wetlands. Additional information on wetland hydroperiods is provided in Section 4-6 of this manual.

Region or Headquarters hydraulics and environmental staff can provide further assistance on hydroperiod modeling. For guidelines on wetland creation or restoration as mitigation for direct wetland impacts, contact the region's wetland biologist or consult the following website: ☞ www.wsdot.wa.gov/Environment/Biology/Wetlands/guidelines.htm

2-6.1.2 Floodplains

Hydrologic storage that is displaced by roadway fill or other structures may result in increased stream flows, channel erosion, downstream flooding, and decreased infiltration and summer base flows. Projects may be required to mitigate loss of hydrologic storage by creating new hydrologic storage elsewhere in the watershed.

A decision to locate structural detention facilities in floodplains depends on the flow control benefits that can be realized. If a detention facility can be placed so that it is functional through at least the 10-year flood elevation, it will accomplish most of its function by controlling peaks during smaller, more frequent events that cumulatively cause more damage. Stormwater facilities that are located outside the 2-year, 10-year, and 25-year flood elevations do not compromise any flood storage during those floods. If it is not possible to locate stormwater facilities anywhere but within the 100-year floodplain, and if flood storage is an issue, consult with the Region Hydraulics Office to identify alternative mitigation opportunities.

2-6.1.3 Aquifers and Wellhead Protection Areas

To ensure highway improvement projects protect drinking water wells, WSDOT has entered into an agreement (☞ www.wsdot.wa.gov/NR/rdonlyres/426DEF64-3BE9-4965-8414-441B878F0D46/0/SCAScreeningCriteria.pdf) with the State Department of Health (DOH). This agreement includes the following screening criteria to determine the conditions under which a highway project will not be considered a potential source of contamination to drinking water wells according to DOH:

1. Road location and construction setbacks are maintained such that the drinking water source intake structure is not in danger of physical damage.
2. All concentrated flows of untreated roadway runoff are directed via impervious channel or pipe and discharged outside the *Sanitary Control Area (SCA)*.
3. If roadside vegetation management practices are identified as a potential source of contamination, the water purveyor will provide the location of the SCA to the appropriate WSDOT Maintenance Office for inclusion in the *Integrated Vegetated Management Plan* for that section of highway as necessary to protect the wellhead.
4. WSDOT complies with all National Pollutant Discharge Elimination System permits, as required per Section 402 of the federal *Water Pollution Control Act*.
5. WSDOT provides the well purveyor with contact information to be used in the event of any problems or questions that may arise.

The project design team must gather and document information on all drinking water wells along the project corridor. Refer to the local critical areas ordinances for details on aquifer and wellhead protection areas applicable to the project site. To locate wells in the project site, check Ecology's website for listed well logs: apps.ecy.wa.gov/welllog/. This website contains a database of wells constructed and registered since the 1930s and wells managed by Ecology since 1971. The WSDOT *GIS Workbench* can also provide a preliminary assessment of wellhead and aquifer protection areas in the vicinity of a given project. Recognize that some wells may not be registered and can only be identified through field investigations. Contact region environmental staff early in the project design phase if there are wells located within the radius of concern.

County health departments set well protection buffers (*Sanitary Control Areas*), presuming that the well protection buffer width will adequately protect wells from contamination. When highway projects encroach into well SCAs, however, WSDOT must document how the project will avoid impacting the well and water supply.

When a road project is expected to intersect a public water supply well's SCA, contact the water purveyor to confirm the location of the well and its SCA. If the project intersects the SCA, a licensed professional engineer, using the screening criteria listed above, needs to establish the conditions under which a highway project will not be considered a potential source of contamination to drinking water wells. Then, the engineer needs to attest to the well purveyor in writing, on WSDOT letterhead, that the screening criteria's conditions are satisfied. It is expected that the purveyor will identify and sign SCA-restrictive covenants and/or WSDOT will check for such covenants filed with the County Auditor's Office.

If a disagreement arises between the water purveyor and WSDOT region staff regarding the potential impacts of the project to a public water supply well that cannot be resolved, elevate the issue to HQ Environmental Services Office (ESO) Stormwater

and Watersheds Program staff. Likewise, contact HQ ESO Stormwater and Watersheds Program staff to evaluate mitigation options if it is not possible to meet the screening criteria.

Projects that include large cuts or compaction of soil over shallow aquifers could potentially intercept groundwater flows and restrict the quantity of water reaching a well. Groundwater quantity issues are not covered by the State Department of Health agreement; thus, potential groundwater quantity impacts must be analyzed as a hydrogeologic issue in consultation with the HQ Materials Laboratory and the HQ Hydraulics Office.

2-6.1.4 Streams and Riparian Areas

To prevent direct impacts on stream channels and stream ecosystems, avoid encroachment into riparian areas. Removing riparian vegetation may directly result in channel instability and streambank erosion; loss of aquatic and wildlife habitat; loss of spawning gravels; increased sedimentation; increased water temperatures; decreased dissolved oxygen concentrations; and other water quality impacts. When a highway-widening project is located parallel to a stream, stormwater facility placement must occur away from the stream to the extent practicable and measures must be taken to preserve or enhance riparian buffers.

2-6.2 Endangered Species

Projects with a federal nexus (those with federal funding, permit, or approval) must go through consultation according to Section 7 of the federal Endangered Species Act (ESA). A biological evaluation or biological assessment must be prepared whenever it is suspected that ESA-listed species inhabit the vicinity of a project.

The design team works with a WSDOT region biologist to develop the required ESA documentation. The information needed to complete the biological evaluation or biological assessment can be obtained from existing documents and resources for the given conceptual project design alternatives. Ideally, the majority of the final information will be gathered during the scoping phase of project development. The scoping team must contact the biologist early in the scoping process to request assistance in determining ESA-related issues and how these issues and needs affect project design and cost considerations.

Information necessary to complete a biological evaluation or biological assessment for stormwater-related impacts is compiled in the ESA Stormwater Design [NEPA/SEPA Documentation Checklist](#) available at:

www.wsdot.wa.gov/Environment/Biology/BA/default.htm

2-6.3 Contaminated and Hazardous Waste Sites

If a project contains a contaminated or hazardous waste site, or if it is suspected that such a site exists within the project limits, contact Headquarters Hazardous Materials Program staff

for further direction. Refer to the *Environmental Procedures Manual*, Section 447.05, Technical Guidance, for further information.

2-6.4 Airports

Special consideration must be given to the design of stormwater facilities for projects located near airports. Roadside features, including standing water (such as wet ponds) and certain types of vegetation, can attract birds both directly and indirectly. The presence of large numbers of birds near airports creates hazards for airport operations and must be avoided. Before planning and designing facilities for a project near an airport, contact WSDOT Aviation, the airport, and the Federal Aviation Administration for wildlife management manuals and other site-specific criteria.

2-6.5 Bridges

Because the over-water portion of the bridge surface captures only the portion of rainfall that otherwise would fall directly into the receiving water body, that portion of the bridge makes no contribution to the increased rate of discharge associated with surface runoff to the water body. This reasoning assumes that the conveyance system is constructed to prevent any localized erosion between the bridge surface and the outfall to the water body. While this fact may simplify needs for flow control, bridges present challenges associated with pollutant removal from runoff generated by their surfaces.

Bridges are typically so close to receiving waters that it is often difficult to find sufficient area in which to site a treatment solution. In the past, bridges were constructed with small bridge drains that discharged the runoff directly into the receiving waters by way of downspouts. This practice is no longer allowed, thus creating the challenge of incorporating runoff collection, conveyance, and treatment facilities into the project design.

Use of suspended pipe systems to convey bridge runoff must be avoided whenever possible because these systems have a tendency to become plugged with debris and are difficult to clean. The preferred method of conveyance is to hold the runoff on the bridge surface and intercept it at the ends of the bridge with larger inlets. This method requires adequate shoulder width to accommodate flows so that they do not spread farther into the travel way than allowed (see Chapter 5 of the *Hydraulics Manual* for allowable spread widths). In cases where a closed system must be used, it is recommended that bridge drain openings and pipe diameters be larger and that 90° bends be avoided to ensure the system's operational integrity. Early coordination with the HQ Bridge and Structures Office is essential if a closed system is being considered.

2-6.6 Ferry Terminals

A ferry dock consists of the bridge (trestle and span), piers, and some of the holding area (parking facility). The terminal is the dock and all associated upland facilities. Requirements and consideration for the terminal's upland facilities are the same as for park-and-ride lots, rest areas, and maintenance yards (where similarities exist) as described in Section 2-6.7. Requirements and considerations that apply to bridges also apply to the trestle, span, and other over-water portions (see Section 2-6.5).

2-6.7 Maintenance Yards, Park-and-Ride Lots, and Rest Areas

The Ecology stormwater management manuals for western (SMMWW) and eastern (SMMEW) Washington provide more specific stormwater BMP information related to parking lots and commercial and industrial land uses. Stormwater facility design must give consideration to the use of methods that emphasizes conservation and the use of on-site natural features to protect water quality and more closely mimic predevelopment hydrology. In addition to approaches in contained Ecology's stormwater management manuals, refer to Chapter 5 for other applicable BMPs.

2-7 How Stormwater Management Applies to a Project

2-7.1 HRM Minimum Requirements and Exemptions

Chapter 3 contains the manual's minimum requirements for stormwater management: Section 3-2 aids in determining the applicable minimum requirements and Section 3-3 provides further detailed direction regarding their application. Even when projects do not trigger a particular minimum requirement (such as flow control), the intent of the minimum requirement should still be considered in project design.

Section 3-2 provides information on projects that are exempt from the minimum requirements. Sections 3-3.5 and 3-3.6 provide specific information on limited exemptions from runoff treatment (Minimum Requirement 5) and flow control (Minimum Requirement 6), respectively.

2-7.2 Local Requirements

Section 1-1.5 explains the conditions under which local requirements apply to stormwater management on WSDOT projects. By state statute, WSDOT projects on state right of way are not subject to local permits, except for *shoreline* permits required by the local shoreline master program and permits required by *critical* or *sensitive areas* ordinances promulgated under the Growth Management Act (see Section 2-6.1).

Permitting staff in the Region Environmental Office must be consulted as to the individual permits required for a project. If the project will result in a new stormwater discharge to a municipal storm sewer system, a permit may be required by that jurisdiction's stormwater utility. Local agencies may have special design requirements for projects in which a portion of the local system will be replaced and turned over to the local jurisdiction for operation and maintenance.

The above information is intended to specify the local permits that may be applicable to WSDOT projects; it is not intended to preclude the need to work with local authorities to address concerns they may have regarding the potential impacts of a project. Additional information on applicable statutes, regulations, and environmental permitting can be found in the *Environmental Procedures Manual*.

2-7.3 Watershed and Basin Plans

Incorporating watershed and basin planning and local requirements into stormwater management is addressed in Minimum Requirement 8 (see Section 3-3.8). Project planners and designers need to familiarize themselves with the planning efforts for the watersheds and local jurisdictions in which the project is located and identify any specific requirements, recommendations, and opportunities that relate to stormwater management. Watershed plans may also identify priority mitigation needs within the watershed that may present off-site opportunities to mitigate project impacts. Local plans may have identified specific stormwater-related needs and/or contain useful analyses.

Statewide organized watershed planning efforts occur under two state laws: the Watershed Planning Act (2514 Planning) and the Salmon Recovery Act (2496 Planning). Each uses *water resource inventory areas* (WRIAs) as its basic geographic unit.

Basin planning conducted by local governments focuses on drainage basins at a sub-WRIA scale. Unfortunately, there are no uniform state standards defining an adequate basin plan. As stated in Minimum Requirement 8 (see Section 3-3.8), standards developed from basin plans cannot modify any minimum requirement until the basin plan is formally adopted and implemented by the local governments within the basin and has received approval or concurrence from Ecology.

Entities with basin planning responsibilities for an area where transportation projects are planned must be contacted as early as possible in the project planning process. Such groups include *lead entities* under the Salmon Recovery Act and *watershed planning units* under the Watershed Planning Act as well as city and county public works departments responsible for basin planning. There may be shared funding opportunities for local priority mitigation projects, which could significantly reduce project mitigation costs. Also, such entities may have data and analyses that can be used in the project planning process.

- Information on activities under the Watershed Planning Act, including a map of Washington's water resource inventory areas, is available at:
☞ www.ecy.wa.gov/watershed/index.html
- Information on activities under the Salmon Recovery Act is available at:
☞ wdfw.wa.gov/recovery.htm
- Watershed data, reports, and other related information is available at:
☞ www.ecy.wa.gov/programs/eap/wrias/index.html

Contact the Region Environmental Office or the HQ ESO Stormwater and Watersheds Program to arrange meetings and help coordinate watershed-related efforts.

2-7.3.1 Watershed-Based Approach

The Stormwater and Watersheds Program staff of the HQ Environmental Services Office has developed a project screening and watershed characterization process to identify alternatives to managing stormwater impacts within the right of way. The objectives in pursuing the watershed-based approach are to improve environmental benefits and reduce costs compared to standard runoff treatment and flow control facilities constructed within the right of way. Factors to consider with watershed-based options include the following:

1. *Have all source controls been included?* Source control may be the most cost-effective practice to control pollutants. This is the first step in the investigation of alternative treatment options.
2. *What size watershed scale is appropriate for this alternative mitigation approach?* While the smallest subbasin may be appropriate for healthy watersheds, a larger watershed scale may be more appropriate in highly degraded watersheds depending on the nature of the impairment(s).
3. *Can stormwater management be coordinated with habitat mitigation?* Stream restoration, floodplain restoration, riparian replanting, or other practices could provide both habitat mitigation and stormwater management.
4. *Has a regional facility been evaluated?* If on-site stormwater facilities are not feasible, combining several project stormwater treatment/control needs into one regional facility may be a more cost-effective option.
5. *Are there legal or regulatory constraints to off-site stormwater management?*

For information on the activities of WSDOT's Watershed Program, including the watershed-based mitigation method, see: ☞ www.wsdot.wa.gov/environment/watershed/default.htm

2-7.4 Engineering and Economic Feasibility

For some projects, practical limitations may present obstacles to fully meeting certain requirements, particularly runoff treatment and flow control, within the project right of way.

Limitations may be infrastructural, geographical, geotechnical, hydraulic, environmental, or benefit/cost-related. For these projects, the planning and design team must make a formal assessment of the project and identify constraints on meeting the minimum requirements. This assessment is referred to as *engineering and economic feasibility* (EEF).

The Engineering and Economic Feasibility Evaluation Checklist, included in Appendix 2A, is an evaluation based on 18 project- and site-specific criteria that assesses the practical limitations of constructing stormwater facilities within or adjacent to a project's right of way. The assessment must be performed as early as possible in project development. If the assessment reveals that stormwater requirements for a project cannot be met because it is not practicable to do so, an explanation must be provided in the project's Hydraulic Report. The explanation must include the reasons why the requirements cannot be met for the site and the amount of stormwater treatment/control that can be provided. Whenever an EEF assessment shows that meeting the HRM's minimum requirements for a project is not feasible within the project's right of way, in whole or in part, the project team must consult with the Region Environmental Office or the HQ ESO Stormwater and Watersheds Program regarding whether alternative mitigation opportunities have been identified for the project site.

If on-site options are unavailable and opportunities to create off-site runoff treatment and/or flow control capacity cannot be identified or are not chosen, the project needs to pursue the *demonstrative approach* to propose a treatment option for the stormwater discharge (see Sections 1-1.3 and 5-3.5.3). Such a proposal may involve using off-site or watershed-based options to create runoff treatment and flow control capacity to meet regulatory requirements (see Section 2-7.3). The *demonstrative approach* requires demonstrating that the project will not adversely affect water quality by providing appropriate supporting data showing that the alternative approach satisfies state and federal water quality laws. The timeline and expectations for providing technical justification depend on the complexity of the individual project and the nature of the receiving water environment. Thus, this approach may be more cost-effective for large, complex, or unusual types of projects. In developing alternate treatment and control options, it is important to consider and document the site limitations using the Engineering and Economic Feasibility Evaluation Checklist (see Appendix 2A).

2-7.5 Stormwater Retrofit

Stormwater retrofit provides treatment/control improvements for existing and/or replaced impervious surfaces where existing treatment/controls do not exist or are substandard. The decision to apply current *Highway Runoff Manual* standards for runoff treatment and flow control to existing impervious surfaces within the project limits should occur during project scoping. Section 3-4 provides guidelines for assessing (1) whether project-driven stormwater retrofit obligations can be met off-site by retrofitting an equivalent area of state highway in targeted environmental priority locations, and (2) whether it is cost-effective to provide stormwater management retrofits beyond what is called for under these requirements.

Stormwater retrofit may also be accomplished as a stand-alone programmed project (I-4 Subprogram). Those responsible for scoping a highway project need to contact the Region or

HQ Program Management Office to learn whether any such programmed retrofit actions apply to their project.

The extent and type of any stormwater retrofit activity needs to be documented in the Hydraulic Report and the Stormwater Design Documentation Spreadsheet available at:

☞ www.wsdot.wa.gov/Environment/WaterQuality/Runoff/HighwayRunoffManual.htm

**Engineering and Economic Feasibility
for Construction of Stormwater
Management Facilities**

Appendix 2A. Table of Contents

Appendix 2A.	Engineering and Economic Feasibility for Construction of Stormwater Management Facilities	2A-1
2A-1	General Criteria: Engineering and Economic Feasibility (EEF) of Constructing Stormwater Control Facilities	2A-1
2A-2	Engineering and Economic Feasibility (EEF) Evaluation Checklist.....	2A-2
2A-2.1	Collect Project Site Data to Identify Limiting Factors.....	2A-2
2A-2.2	Infrastructure Limitations to Construction Feasibility	2A-4
2A-2.3	Geographic and Geotechnical Limitations to Construction Feasibility.....	2A-7
2A-2.4	Hydraulic Limitations to Construction Feasibility.....	2A-8
2A-2.5	Environmental or Health Risk Limitations to Construction Feasibility.....	2A-9
2A-2.6	Cost Limitations to Construction Feasibility	2A-11

Appendix 2A.

Engineering and Economic Feasibility for Construction of Stormwater Management Facilities

Stormwater runoff from highways should be treated and controlled adjacent to or within the right of way (ROW) when transportation improvement projects are constructed. However, various site-specific factors (for example, lack of land availability; engineering constraints; health and safety issues associated with operations and maintenance activities; or other obstacles) could make constructing stormwater management facilities within or adjacent to the highway right of way (called *in-ROW treatment*) difficult, if not impossible.

This appendix presents a method to assist in determining when site-specific factors could make constructing stormwater management facilities within or adjacent to the highway right of way infeasible. Using the Engineering and Economic Feasibility (EEF) Evaluation Checklist (see Section 2A-2) to document the critical site-specific limiting factors is required if the project deviates from prescribed stormwater management design criteria, such as those contained in the *Highway Runoff Manual* (HRM) or the Washington State Department of Ecology's (Ecology's) stormwater management manuals for eastern (SMMEW) and western (SMMWW) Washington. This documentation is necessary, in addition to the analysis required to seek compliance through the *demonstrative approach*. The demonstrative approach requires approval of a site-specific stormwater management proposal and supporting data to show that the alternative approach protects water quality and satisfies state and federal water quality laws (see Sections 1-1.3 and 5-3.5.3). Such a proposal may involve using off-site or watershed-based options to create runoff treatment and flow control capacity to meet regulatory requirements (see Section 2-7.3).

2A-1 General Criteria: Engineering and Economic Feasibility (EEF) of Constructing Stormwater Control Facilities

The following four general criteria should be considered by the designer in the siting and selection of stormwater best management practices (BMPs). These criteria affect the feasibility of stormwater BMPs and are further explained in the EEF Checklist in Section 2A-2.

- **Physical site limitations.** In many cases, the amount of available right of way determines which types of stormwater controls are feasible for the project. When additional right of way can be acquired at market value, or when eminent domain condemnations can be demonstrably justified, then project proponents should explore these options to acquire additional land for stormwater control facilities. Historically, condemning land specifically for wetland mitigation (also triggered by the federal Clean Water Act) has been extremely difficult; hence, this option for stormwater control facilities will likely encounter the same difficulties.

Additional site constraints could include geographic limitations, steep slopes, soil instability, proximity to water bodies, presence of significant cultural resources, and shallow water tables.

- **Treatment effectiveness.** Generally, BMPs with the highest pollutant-removal efficiencies should be considered first. These practices may require more land area, thus affecting space limitations.
- **Costs and associated environmental benefits.** Generally, the most cost-effective method of meeting environmental requirements should be chosen.
- **Legal and policy issues.** Washington State Department of Transportation (WSDOT) and Ecology stormwater requirements and design criteria, local ordinances, Endangered Species Act concerns, and tort liability issues must also be considered when selecting appropriate BMPs. If watershed-based stormwater management options are considered, legal and policy issues discouraging this approach may need to be overcome.

When identifying on-site treatment and control options, it is important to consider the site limitations preventing construction of stormwater control and treatment facilities. For physical or economic reasons, it may not be feasible to construct full-scale stormwater control facilities on-site.

2A-2 Engineering and Economic Feasibility (EEF) Evaluation Checklist

The following checklist is intended for use by WSDOT staff during the design stage to determine whether construction of stormwater control facilities is feasible within the immediate highway right of way. Factors that limit the feasibility of constructing in-ROW stormwater controls are listed, along with questions to help transportation project planners and designers determine the feasibility of constructing in-ROW stormwater treatment and control systems based on site conditions.

2A-2.1 Collect Project Site Data to Identify Limiting Factors

Project information such as boundaries, soil conditions, presence of slopes, proximity of water bodies, and other project data must be collected to determine in-ROW treatment and control feasibility. Preliminary estimates of runoff treatment and flow control needs for the project must also be made. At a minimum, this analysis should include the anticipated new and existing total impervious areas within the right of way; topographic characteristics; existing land use and land cover adjacent to the right of way; and whether on-site soil characteristics can accommodate infiltration.

The following list contains the information needed to complete a full EEF analysis for constructing stormwater control facilities within a specific highway right of way. It should be noted that, in many cases, not all of the information listed below is needed to make a feasibility determination. Once a fatal flaw is identified in the checklist that makes it infeasible to construct in-ROW stormwater control facilities, then the EEF analysis is

effectively completed, thus negating the need for additional information to evaluate in-ROW feasibility.

- Conceptual-level stormwater design: Is infiltration possible based on soil characteristics?
- Amount of right of way currently available or that can be reasonably acquired via purchase or condemnation.
- Location(s) of critical public infrastructure(s) relative to the established or acquirable right of way.
- Location(s) of protected cultural resources, historic sites, parklands, or wildlife and waterfowl refuges (Department of Transportation Act of 1966 §4[f] properties) relative to the established or acquirable right of way.
- Location(s) on or adjacent to the established or acquirable right of way that are designated as sensitive by a federal, state, local, or tribal government. These areas include, but are not limited to:
 - Water bodies designated as “impaired” under the provision of Section 303(d) of the federal Clean Water Act enacted by Public Law 92-500.
 - Designated “critical water resources” as defined in 33 CFR Part 330, Nationwide Permit Program.
 - Sole source aquifers as defined under the Safe Drinking Water Act, Public Law 93-523.
 - Wellhead protection zones as defined under WAC 246-290, Public Water Supplies.
 - “Critical habitat” as defined in Section 3 of the Endangered Species Act of 1973.
 - Areas identified in local critical area ordinances or in an approved basin plan.
- Location(s) of established structure(s) on or adjacent to the established or acquirable right of way.
- Slopes and location(s) of unstable slopes on or adjacent to the established or acquirable right of way.
- Available hydraulic head.
- Depth of the mean annual high groundwater table and information on local groundwater flooding.
- Presence and location of hazardous or dangerous materials on or adjacent to the established or acquirable right of way.

- Existence and location(s) of well-established riparian tree canopies or vegetative buffers on the established or acquirable right of way.
- Presence and distribution of 100-year floodplains on or adjacent to the established or acquirable right of way.
- For bridge projects: Can the bridge structure be drained to land by gravity feed?
- Estimated cost for constructing and maintaining the conceptual stormwater control facilities for the drainage area.

2A-2.2 Infrastructure Limitations to Construction Feasibility

The density of the built environment adjacent to the established right of way may limit the amount of land available for acquisition to construct stormwater treatment and control systems. Once project limits, right of way, and stormwater runoff treatment and flow control needs are defined, a determination on whether it is feasible to construct stormwater management systems on-site can be made. Generally, wet vaults should be avoided when other BMP options are viable because of high construction and maintenance costs.

The following questions should be considered when determining whether infrastructure or right of way limits the feasibility of designing and constructing stormwater BMPs within or adjacent to the right of way (in-ROW treatment). Each element evaluates potential fatal flaws that would preclude the feasibility of constructing stormwater management facilities within the anticipated right of way of the project being scoped.

- 2A-2.2.1. Can a multipurpose runoff treatment system, such as an extended wet/detention pond or pond/constructed wetland or floodplain restoration project be constructed within the anticipated right of way to treat the estimated water quality and flow impacts of the project? (YES/NO)

*EEF implications: This is to reinforce that facilities designed and constructed to treat larger areas result in lower unit volume treatment costs, which will affect the benefit/ cost ratio, which can affect overall feasibility. If **YES**, go to Section 2A-2.3. If **NO**, proceed to Section 2A-2.2.2.*

- 2A-2.2.2. Can runoff treatment BMPs be designed to fit within the anticipated right of way? (YES/NO)

Consider these BMPs (in order of preference):

- Infiltration or exfiltration via ponds, trenches, depressions, groundwater contactors, or drain fields
- Compost-amended vegetated filter strips
- Ecology embankments
- Wet/detention ponds

- Biofiltration swales and filter strips
- Constructed wetlands
- Vaults and tanks (use requires preauthorization; see Section 5-3.6.1)

EEF implications: If YES, proceed to Section 2A-2.2.3. If NO, go to Section 2A-2.2.4. In many instances, it may be possible to fit in-ROW BMPs for runoff treatment only, since some runoff treatment BMPs can be engineered to fit within highly constrained land parcels (such as compost-amended filter strips and ecology embankments), whereas flow control BMPs tend to require more land.

2A-2.2.3. Can flow control BMPs be designed to fit within the anticipated right of way? (YES/NO)

Consider these BMPs (in order of preference):

- Low-impact development (LID) methods such as minimizing clearing and compaction; retaining mature stands of vegetation and soil horizons; soil enhancements; routing runoff to closed vegetated depressions (bioretention); compost-amended vegetated buffer strips; porous pavement shoulders and gore areas; and dispersion
- Floodplain restoration projects designed to increase stormwater storage
- Infiltration or exfiltration
- Dispersion BMPs
- Wet/detention ponds
- Extended detention (dry) ponds
- Vaults and tanks (use requires preauthorization; see Section 5-3.6.1).

EEF implications: If YES, go to Section 2A-2.3; it has been established that there is enough land area within the anticipated right of way to construct BMPs. Other constraining factors, such as geotechnical, geographic, and environmental, may also limit the feasibility of constructing in-ROW BMPs and need to be examined to complete the EEF analysis. If NO, proceed to Section 2A-2.2.4.

2A-2.2.4. If BMPs cannot be accommodated on-site, is it feasible to purchase adjoining properties to allow the construction of one of the above BMP designs?

In order to answer this question, the following associated questions need to be answered.

2A-2.2.4.1 Are there critical publicly owned infrastructure(s) or facilities, such as schools, fire stations, police facilities, or major utility lines, that would need to be

relocated to facilitate construction of in-ROW stormwater control facilities?
(YES/NO)

EEF implications: If YES, it is generally not feasible to construct in-ROW stormwater control facilities due to the existence of critical public infrastructure(s). Identification of the location and nature of the critical public infrastructure(s) needs to be well documented to regulatory agencies, to justify not constructing in-ROW stormwater control facilities. Consider using off-site or watershed-based options (see Sections 1-1.3 and 2-7.3) to create additional capacity in the receiving water so that the project will meet water quality standards. If NO, proceed to Section 2A-2.2.4.2.

| 2A-2.2.4.2 Will the designated stormwater management area for constructing a stormwater management facility trespass on or disturb designated historic building sites, structures, archaeological sites, or other significant cultural resources? (YES/NO)

Note: Any projects involving disturbance of ground surfaces not previously disturbed should be reviewed for cultural resource study needs (such as site file searches at the Washington State Office of Archaeology and Historic Preservation, on-site surveys, and subsurface testing). Federal involvement (such as funding, permits, and lands) requires compliance with Section 106 of the National Historic Preservation Act and implementation of regulations in 36 CFR 800.

EEF implications: If YES, it is not feasible to construct in-ROW stormwater control facilities due to the existence of statutorily protected cultural resources at the site. At this point, the EEF analysis is complete. Identification of the location and nature of the critical public infrastructure(s) needs to be well documented to resource agencies, to justify not constructing in-ROW stormwater control facilities. Other options to create capacity should be identified to maintain or restore the water quality, eliminate the hydrology impacts of the project, and comply with the antidegradation clause of the federal Clean Water Act. Consider using off-site or watershed-based options (see Sections 1-1.3 and 2-7.3) to create additional capacity in the receiving water so that the project will meet water quality standards. If NO, proceed to Section 2A-2.2.4.3.

| 2A-2.2.4.3 Is the land needed to site and construct the stormwater management facility available at a reasonable cost without significant displacement or other impacts? In other words, is the needed additional land available for purchase from a willing seller at market value, at a cost acceptable to the project budget, or by eminent domain condemnation procedures? (If the required land lies within an area with expensive privately owned structures and buildings, the cost of acquisition and relocation may greatly exceed market rates for the land itself.) (YES/NO)

EEF implications: This query evaluates whether it is feasible to purchase additional right of way to accommodate construction of in-ROW stormwater control facilities. If YES, proceed to Section 2A-2.3, since additional land can be practicably purchased, and project offices should continue with the EEF analysis to investigate whether there are other factors limiting feasibility. If NO, it is not feasible to construct stormwater control facilities within the right of way, and other options to create capacity should be identified to meet regulatory requirements. Consider using off-site or watershed-based options (see Sections 1-1.3 and 2-7.3) to create additional capacity in the receiving water so that the project will meet water quality standards.

2A-2.3 Geographic and Geotechnical Limitations to Construction Feasibility

A project's topography and/or proximity to wetlands, sensitive water bodies, shorelines, riverfront areas, or steep slopes may physically or structurally preclude construction of BMPs on-site within required engineering standards. In situ geotechnical conditions can also limit the feasibility of constructing BMPs within the right of way (for example, the project is on unstable slopes, high shrink/swell soils, or karst topography). The following questions should be considered when determining whether geography or geotechnical limits affect the feasibility of designing stormwater BMPs on-site:

- 2A-2.3.1 Is the project located adjacent to or on a water body, wetland, riparian buffer, or other natural aquatic feature that would physically preclude the construction of any in-ROW BMP? Examples of water bodies that could geographically limit a WSDOT project include lakes, rivers, streams (including intermittent streams), wetlands, sloughs, wet meadows, natural ponds, sounds, and seas. (YES/NO)

EEF implications: If YES, it is not feasible to construct in-ROW stormwater control facilities because of geographic limitations. Project offices should review project plans to evaluate whether it is feasible to reconfigure drainage and BMP designs to accommodate as much stormwater treatment/control as can practicably fit within the right of way. Other options to create capacity should be identified to maintain or restore the water quality and hydrology baselines impacted by the project and to comply with the antidegradation clause of the federal Clean Water Act and Washington State Water Pollution Law (RCW 90.48). Consider using off-site or watershed-based options (see Sections 1-1.3 and 2-7.3) to create additional capacity in the receiving water so that the project will meet water quality standards. If NO, proceed to Section 2A-2.3.2.

- 2A-2.3.2 Do extremely steep slopes (steeper than 2H:1V) exist at the proposed BMP location?

EEF implications: If YES, it is not feasible to construct in-ROW stormwater control facilities because of geographic limitations. Project offices should review project plans to evaluate whether or not it is feasible to reconfigure drainage and BMP

*designs to accommodate as much stormwater treatment/control as can practicably fit within the right of way. Other options to create capacity should be identified to maintain or restore the water quality and hydrology baselines impacted by the project and to comply with the antidegradation clause of the federal Clean Water Act and Washington State Water Pollution Law (RCW 90.48). Consider using off-site or watershed-based options (see Sections 1-1.3 and 2-7.3) to create additional capacity in the receiving water so that the project will meet water quality standards. If **NO**, proceed to Section 2A-2.3.3.*

- 2A-2.3.3 Does the land needed for construction of runoff treatment or flow control facilities lie within 50 feet of any slope greater than 15%? (YES/NO)

*EEF implications: This is a setback specification encoded in Ecology's new stormwater manuals and reflected in the Highway Runoff Manual. If **NO**, proceed to Section 2A-2.4.1. If **YES**, consult with a geotechnical engineer to determine whether there is a risk of slope failure because of slope and soil characteristics. If there is an unacceptable risk of slope failure, it is not feasible to construct in-ROW stormwater control facilities on the designated BMP site. Other options to create capacity should be identified to maintain or restore the water quality and hydrology baselines impacted by the project and to comply with the antidegradation clause of the federal Clean Water Act and State Water Pollution Law (RCW 90.48). Consider using off-site or watershed-based options (see Sections 1-1.3 and 2-7.3) to create additional capacity in the receiving water so that the project will meet water quality standards.*

2A-2.4 Hydraulic Limitations to Construction Feasibility

Hydraulic limitations can include the lack of hydraulic head necessary to effectively operate stormwater control facilities or areas with very shallow water tables such as floodplains or seasonal wetlands. Alternatives such as spill control devices and frequent cleaning of road or bridge surfaces with high-efficiency vacuum sweepers should be considered in these areas in lieu of standard treatment facilities.

- 2A-2.4.1 Will BMP construction involve excavating to below annual high groundwater levels? (YES/NO)

*EEF implications: If **YES**, consideration should be given to altering the stormwater system design to use other BMP options. If other BMP options are also found not to be feasible, it is not feasible to construct in-ROW BMPs and the EEF analysis is complete. If **NO**, proceed to Section 2A-2.4.2.*

- 2A-2.4.2 Will construction of an infiltration BMP result in localized groundwater flooding (such as basement inundation) or will it be located less than 20 feet from any upslope foundation or less than 100 feet from any downslope foundation? (YES/NO)

EEF implications: If YES, consider other BMPs or use impermeable barriers to protect existing foundations if found to be feasible. If NO, proceed to Section 2A-2.4.3.

- 2A-2.4.3 Is there adequate hydraulic head (dependent on the type of BMP, but generally greater than 3 feet) available to effectively operate the BMP? (YES/NO)

EEF implications: If NO, consideration should be given to altering the design to use other BMP options. If other BMP options are also found not to be feasible, it is not feasible to construct in-ROW stormwater control systems. If YES, proceed to Section 2A-2.4.4.

- 2A-2.4.4 Specifically for bridge projects, is it feasible from an engineering perspective to convey stormwater to on-land stormwater control facilities by gravity feed and have a flowpath of less than 2,000 feet to shore? (YES/NO)

EEF implications: If NO, the inability to drain bridge structures by gravity feed, whether because of expansion joints, grated sections, or the lack of grade, makes it not feasible to convey stormwater to land for treatment. Project offices should evaluate whether it is possible to alter project design to accommodate gravity drainage to land. If not, other options to create capacity should be identified to maintain or restore the water quality and hydrology baselines impacted by the project and to comply with the antidegradation clause of the federal Clean Water Act and State Water Pollution Law (RCW 90.48). Consider using off-site or watershed-based options (see Sections 1-1.3 and 2-7.3) to create additional capacity in the receiving water so that the project will meet water quality standards. If YES, proceed to Section 2A-2.5.

2A-2.5 Environmental or Health Risk Limitations to Construction Feasibility

Areas with intensive historic levels of industrial or commercial activity may have significant levels of soil, water, or fill contamination, which would prevent highway construction work from being conducted in a safe manner (as specified in the Washington Industrial Safety and Health Act or federal Occupational Safety and Health Administration regulations), or may be the subject of overriding Resource Conservation and Recovery Act (RCRA), state Model Toxics Control Act (MTCA), or Comprehensive Environmental Response, Compensation, and Liability Act (CERCLA) regulations. Such significant safety, health, and environmental limitations would generally preclude construction of stormwater facilities on a particular site.

- 2A-2.5.1 Does the proposed stormwater management area contain significant quantities of contaminated soils or materials to designate it as a hazardous or dangerous waste area or require a cleanup action as defined by RCRA or MTCA regulations? (YES/NO)

EEF implications: If YES, go to Section 2A-2.6 to evaluate benefit-to-cost ratios, incorporating estimated costs for remediation of hazardous or dangerous materials into the analysis. Construction of stormwater facilities in areas with hazardous or dangerous wastes is generally not feasible without putting a worker's health in jeopardy and may result in releases of acutely toxic substances to surface waters during the construction phase and impacts to groundwater in the operations phase. If NO, proceed to Section 2A-2.5.2.

- 2A-2.5.2 Will the construction of stormwater control facilities require the removal of well-established riparian tree canopies (generally trees over 100 feet tall) or vegetative buffers? (YES/NO)

EEF implications: If YES, the benefit/cost (B/C) analysis will determine feasibility if no other limiting factors are found, so go to Section 2A-2.6. Well-established tree canopies can sequester significant amounts of air and water pollutants, provide long-term water storage, and provide shading that buffers temporal in-stream temperature increases. Project offices should reevaluate drainage and BMP designs to investigate whether stormwater control facilities can be reconfigured or moved to avoid or minimize the removal of established tree canopies.

If avoidance and minimization are not possible, other options to create capacity should be identified to maintain or restore the water quality and hydrology baselines affected by the project and to comply with the antidegradation clause of the federal Clean Water Act and State Water Pollution Law (RCW 90.48). Consider using off-site or watershed-based options (see Sections 1-1.3 and 2-7.3) to create additional capacity in the receiving water so that the project will meet water quality standards. If NO, proceed to Section 2A-2.5.3.

- 2A-2.5.3 Will the construction of stormwater control facilities require the removal of critical habitat for listed endangered and threatened species? (YES/NO)

EEF implications: If YES, it is not feasible to construct in-ROW stormwater control facilities due to environmental limitations. Removal of critical habitat would (at a minimum) result in a Section 7 consultation for the project or would likely result in a take of an endangered or threatened species, making it not feasible to construct in-ROW stormwater control facilities. Project offices should reevaluate drainage and BMP designs to investigate whether stormwater control facilities could be reconfigured or moved to avoid or minimize the removal of critical habitat. If avoidance and minimization are not possible, other options to create capacity should be identified to maintain or restore the water quality and hydrology baselines impacted by the project and to comply with the antidegradation clause of the federal Clean Water Act and State Water Pollution Law (RCW 90.48). Consider using off-site or watershed-based options (see Sections 1-1.3 and 2-7.3) to create additional capacity in the receiving water so

that the project will meet water quality standards. If **NO**, proceed to Section 2A-2.5.4.

- 2A-2.5.4 Is the established or acquirable right of way for stormwater control facilities located within a 100-year floodplain? (YES/NO)

*EEF implications: If **YES**, the established or available land is within a 100-year floodplain and it is not feasible to construct functional stormwater control facilities within the right of way. Project offices should reevaluate drainage and BMP designs to investigate whether stormwater control facilities could be reconfigured or moved to avoid or minimize the 100-year floodplain. If avoidance and minimization are not possible, other options to create capacity should be identified to maintain or restore the water quality and hydrology baselines impacted by the project and to comply with the antidegradation clause of the federal Clean Water Act and State Water Pollution Law (RCW 90.48). Consider using off-site or watershed-based options (see Sections 1-1.3 and 2-7.3) to create additional capacity in the receiving water so that the project will meet water quality standards. If **NO**, proceed to Section 2A-2.6.*

2A-2.6 Cost Limitations to Construction Feasibility

In 2003 WSDOT performed an environmental mitigation cost analysis. Critical factors found to affect stormwater management costs included the location and setting of the specific projects relative to neighborhoods, streams, and wetlands. In addition, projects with poor soil conditions or high water tables generally had considerably higher costs for treating stormwater within the right of way. In discussions with the authors of the cost analysis, it was determined that project delivery would be impeded when stormwater costs exceeded a range of \$5 to \$7 per square foot of contributing impervious surface. Using a range of values allows project offices some flexibility to determine cost/benefit feasibility based on the project's setting.

- 2A-2.6.1 Within individual drainages, will the incremental cost for constructing in-ROW stormwater control facilities be more than \$5 to \$7 per square foot of contributing impervious surface? (YES/NO)

*EEF implications: If **YES**, it is generally not feasible to construct in-ROW stormwater control facilities. Project offices should investigate how project designs can be altered to accommodate more cost-efficient BMPs. Projects within highly urbanized areas or those that may impact significant areas of wetlands or floodplains should generally use the \$7 per square foot criterion, while those projects in more rural areas should generally use the \$5 per square foot criterion for evaluating benefit/cost feasibility. If **NO**, it is feasible to construct stormwater control facilities within or adjacent to the highway right of way.*

Minimum Requirements

Chapter 3. Table of Contents

Chapter 3.	Minimum Requirements.....	3-1
3-1	Introduction	3-1
3-2	Applicability of the Minimum Requirements	3-2
3-2.1	Project Thresholds.....	3-2
3-2.2	Exemptions.....	3-3
3-3	Minimum Requirements.....	3-7
3-3.1	Minimum Requirement 1 – Stormwater Planning	3-7
3-3.1.1	Objective.....	3-7
3-3.1.2	Applicability	3-7
3-3.1.3	Guidelines.....	3-8
3-3.2	Minimum Requirement 2 – Construction Stormwater Pollution Prevention	3-8
3-3.2.1	Objective.....	3-9
3-3.2.2	Applicability	3-10
3-3.2.3	Guidelines.....	3-10
3-3.3	Minimum Requirement 3 – Source Control of Pollutants	3-10
3-3.3.1	Objective.....	3-10
3-3.3.2	Applicability	3-10
3-3.3.3	Guidelines.....	3-11
3-3.4	Minimum Requirement 4 – Maintaining the Natural Drainage System.....	3-11
3-3.4.1	Objective.....	3-11
3-3.4.2	Applicability	3-11
3-3.4.3	Guidelines.....	3-12
3-3.5	Minimum Requirement 5 – Runoff Treatment	3-12
3-3.5.1	Objective.....	3-12
3-3.5.2	Runoff Treatment Exemptions	3-12
3-3.5.3	Applicability	3-13
3-3.5.4	Guidelines.....	3-13
3-3.6	Minimum Requirement 6 – Flow Control.....	3-18
3-3.6.1	Objective.....	3-18
3-3.6.2	Flow Control Exemptions.....	3-18
3-3.6.3	Applicability	3-23
3-3.6.4	Guidelines.....	3-24
3-3.7	Minimum Requirement 7 – Wetlands Protection	3-28
3-3.7.1	Objective.....	3-28
3-3.7.2	Applicability	3-28
3-3.7.3	Guidelines.....	3-28
3-3.8	Minimum Requirement 8 – Incorporating Watershed/Basin Planning Into Stormwater Management	3-29
3-3.8.1	Objective.....	3-29
3-3.8.2	Applicability	3-29

3-3.8.3	Guidelines.....	3-30
3-3.9	Minimum Requirement 9 – Operation and Maintenance.....	3-30
3-3.9.1	Objective.....	3-30
3-3.9.2	Applicability.....	3-31
3-3.9.3	Guidelines.....	3-31
3-4	Stormwater Retrofit Guidelines.....	3-31
3-4.1	Retrofitting Existing Impervious Surfaces and Stand-Alone Priority Stormwater Retrofit Projects	3-33
3-4.1.1	Existing Impervious Surfaces.....	3-33
3-4.1.2	I-4 Subprogram Environmental Retrofit Stormwater Projects.....	3-34
3-4.2	Effective Impervious Surface in Western Washington.....	3-34
3-4.3	Replaced Impervious Surface	3-35
3-4.4	Replaced PGIS	3-35

List of Tables

Table 3-1.	Runoff treatment targets and applications for roadway projects.	3-15
Table 3-2.	Basic Treatment receiving water bodies.	3-16
Table 3-3.	Criteria for sizing runoff treatment facilities in western Washington.	3-17
Table 3-4.	Criteria for sizing runoff treatment facilities in eastern Washington.	3-17
Table 3-5.	Flow control exempt surface waters list.	3-21
Table 3-6.	Western Washington flow control criteria.	3-26

List of Figures

Figure 3.1	Minimum requirement applicability at project level.	3-4
Figure 3.2	Minimum requirement applicability at project level (continued).	3-5
Figure 3.3	Minimum requirement applicability at TDA level.	3-6
Figure 3.4	Stormwater Retrofit Analysis for WSDOT projects.	3-32

Chapter 3. Minimum Requirements

3-1 Introduction

Note to the designer: It is extremely important to take the time to thoroughly understand the minimum requirements presented in this chapter when making stormwater design decisions. A firm grasp of the chapter's terminology is essential; consult the manual's Glossary to clarify the intent and appropriate use of these terms. Direct your questions regarding the minimum requirements and terminology to the region hydraulics representative, the Headquarters (HQ) Hydraulics Office, or the HQ Environmental Services Office.

This chapter describes the nine minimum requirements that apply to the planning and design of stormwater management facilities and best management practices (BMPs) for existing and new Washington State highways, rest areas, park-and-ride lots, ferry terminals, and highway maintenance facilities. In order to plan and design stormwater management systems appropriately, the designer must determine specific parameters related to the project, such as new impervious area created, converted pervious area, area of land disturbance, presence of wetlands, and applicability of basin and watershed plans. Projects that follow the stormwater management practices in this manual achieve compliance with federal and state water quality regulations through the *presumptive approach*. As an alternative, see Sections 1-1.3, 2-7.4, and 5-3.5.3 for a description of using the *demonstrative approach* to protect water resources in lieu of following the stormwater management practices in this manual.

This chapter provides information on applying the following minimum requirements to various types and sizes of projects:

1. Stormwater Planning
2. Construction Stormwater Pollution Prevention
3. Source Control of Pollutants
4. Maintaining the Natural Drainage
5. Runoff Treatment
6. Flow Control
7. Wetlands Protection
8. Watershed/Basin Planning
9. Operation and Maintenance

Not all of the minimum requirements apply to every project. The flowcharts in Figures 3.1, [3.2](#), and [3.3](#) are provided to assist in determining which requirements **may** apply.

Consulting the flowcharts is the initial step in the process. The next critical step

involves reviewing Section 3-2 for the detailed information provided for each minimum requirement in terms of its objective, applicability (and potential exemptions), and guidelines for application. Consult the Glossary to ensure complete understanding of the minimum requirements. Additional guidelines for retrofits are provided in Section 3-4.

Note: For the purposes of this manual, the boundary between eastern and western Washington is the Cascade Crest, except in Klickitat County, where the boundary line is the 16-inch mean annual precipitation contour (isopleth).

3-2 Applicability of the Minimum Requirements

3-2.1 Project Thresholds

Unless otherwise noted, all minimum requirements apply throughout the state. However, in some instances, design criteria, thresholds, and exemptions for eastern and western Washington differ due to different climatic, geologic, and hydrogeologic conditions. Regional differences for each minimum requirement are presented in Section 3-3 under the *Applicability* sections. Additional controls may be required, regardless of project type or size, as a result of adopted basin plans or to address special water quality concerns via a critical area ordinance or a requirement related to the total maximum daily load (TMDL).

All nonexempt projects are required to comply with Minimum Requirement 2. In addition, projects that exceed certain thresholds are required to comply with additional minimum requirements. Use Figures 3.1, 3.2, and 3.3 as the **initial step** in determining which requirements might apply. The **next critical step** involves reviewing the detailed information provided for each applicable minimum requirement in Section 3-3. Consult the Glossary to gain a clear understanding of the following terms, which are essential for correctly assessing minimum requirement applicability.

- New impervious surface
- Converted pervious surface
- Pollution-generating impervious surface (PGIS)
- Pollution-generating pervious surface (PGPS)
- Land-disturbing activity
- Native vegetation
- Non-road-related projects
- Existing roadway prism
- Project limits
- Replaced impervious surface
- Effective impervious surface

- Noneffective impervious surface
- Effective PGIS
- Noneffective PGIS
- Threshold discharge area (TDA)
- Net-new impervious surface

Upgrading by resurfacing state facilities from gravel to bituminous surface treatment (BST or “chip seal”), asphalt concrete pavement (ACP), or Portland cement concrete pavement (PCCP) is considered to be adding new impervious surfaces and is subject to the minimum requirements that are triggered when the thresholds are met.

Basin planning is encouraged and may be used to tailor applicable minimum requirements to a specific basin (see Minimum Requirement 8).

3-2.2 Exemptions

Some types of activities are fully or partially exempt from the minimum requirements. These include some road maintenance/preservation practices and some underground utility projects. The road maintenance and preservation practices that are exempt from all the minimum requirements are:

- Pothole and square cut patching.
- Overlaying existing bituminous surface treatment (BST or “chip seal”), asphalt concrete pavement (ACP), or Portland cement concrete pavement (PCCP) with BST, ACP, or PCCP without expanding the area of coverage.
- Shoulder grading.
- Reshaping/regrading drainage systems.
- Crack sealing.
- Resurfacing with in-kind material without expanding the road prism.
- Vegetation maintenance.
- Upgrading by resurfacing Washington State Department of Transportation (WSDOT) facilities from BST to ACP or PCCP without expanding the area of coverage.¹

¹ This exemption is applicable only to WSDOT projects; whereas, the “gravel-to-BST” exemption in Ecology’s stormwater management manuals is available to local governments. For local governments, upgrades that involve resurfacing from BST to ACP or PCCP are considered new impervious surfaces and are not categorically exempt.

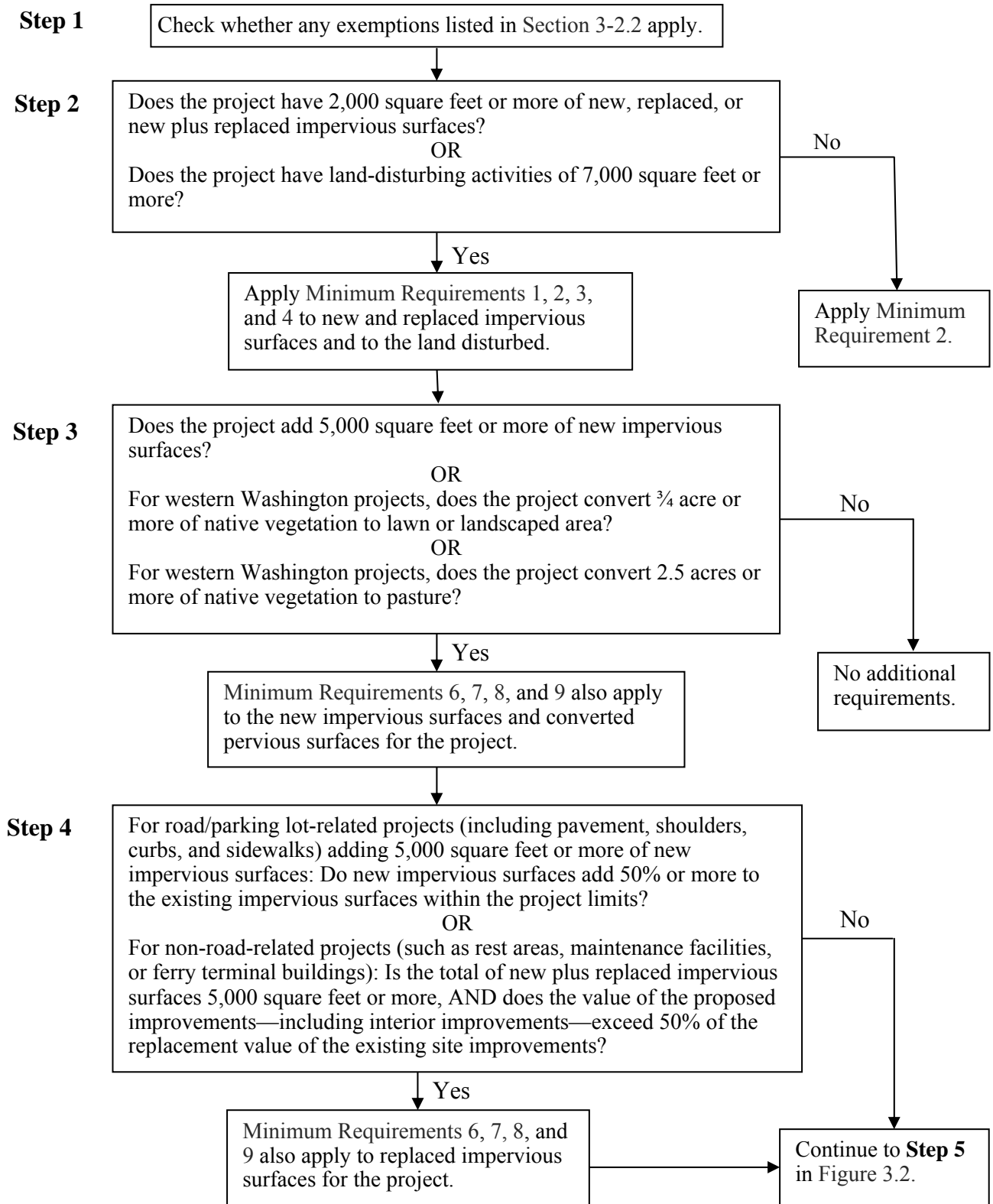

Figure 3.1 Minimum requirement applicability at project level.

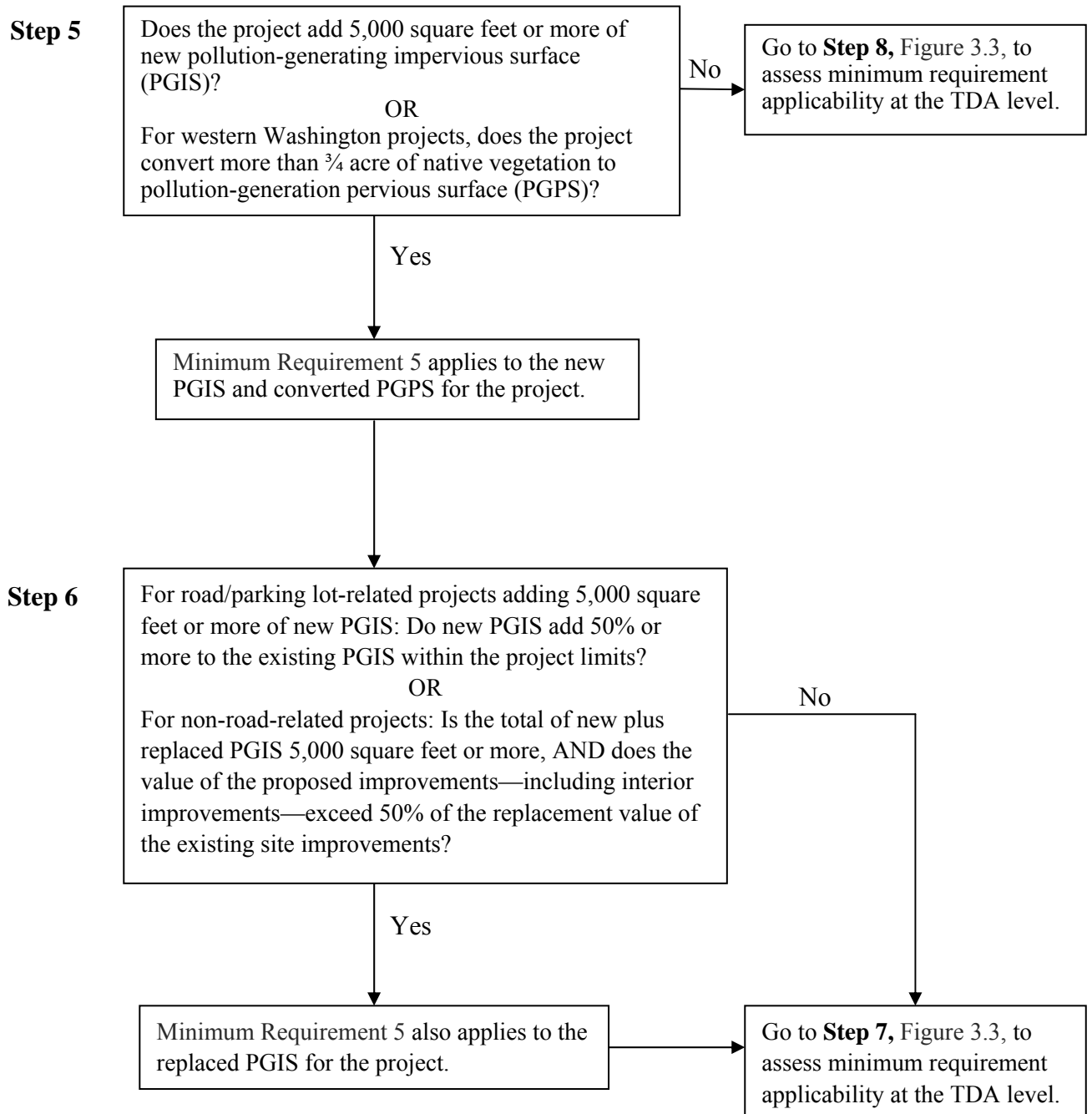

Figure 3.2 Minimum requirement applicability at project level (continued).

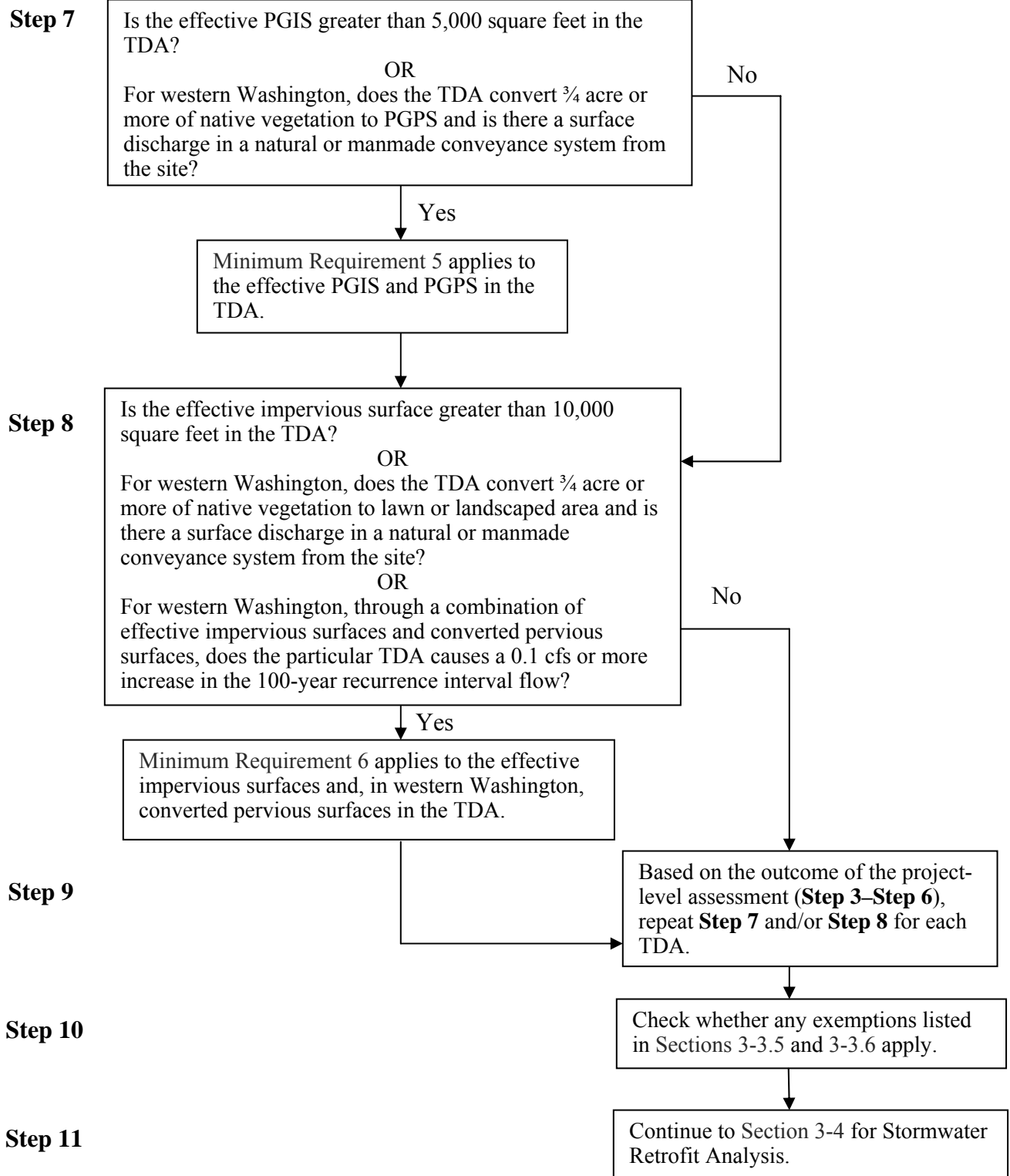

Figure 3.3 Minimum requirement applicability at TDA level.

The following practices are subject only to Minimum Requirement 2, Construction Stormwater Pollution Prevention:

- Underground utility projects that replace the ground surface with in-kind material or materials with similar runoff characteristics
- Removing and replacing a concrete or asphalt roadway to base course, or subgrade or lower, without expanding or upgrading the impervious surfaces
- Repairing the roadway base or subgrade

3-3 Minimum Requirements

This section describes the minimum requirements for stormwater management at project sites. Consult Section 3-2 to determine which requirements apply to any given project. (See Chapter 5 for BMPs to use in meeting Minimum Requirements 3, 5, 6, 7, and 9, and Chapter 6 for BMPs to use in meeting Minimum Requirement 2.)

3-3.1 Minimum Requirement 1 – Stormwater Planning

The two main stormwater planning components of Minimum Requirement 1 are: (1) Construction Stormwater Pollution Prevention Planning, and (2) Permanent Stormwater Control Planning.

Multiple documents are used to fulfill the objective of this requirement, since addressing stormwater management needs is thoroughly integrated into WSDOT's design, construction, and maintenance programs. WSDOT's construction stormwater pollution prevention planning components consist of Spill Prevention, Control, and Countermeasures (SPCC) plans and Temporary Erosion and Sediment Control (TESC) plans. WSDOT's permanent stormwater control planning components include Hydraulic Reports and aspects of the *Maintenance Manual*.

3-3.1.1 Objective

The stormwater planning components collectively demonstrate how stormwater management will be accomplished, both during project construction and in the final, developed condition.

3-3.1.2 Applicability

Minimum Requirement 1 applies to all nonexempt projects that meet the thresholds described in Figure 3.1. Contractors are required to prepare SPCC plans for all projects, since all projects have the potential to spill hazardous materials. All projects that disturb soil must comply with the 12 TESC elements (see Section 6-2.1.2) and must apply the appropriate best management practices (BMPs) presented in Chapter 6. WSDOT prepares a TESC plan if a construction project adds or replaces (removes existing road surface down to base course)

more than 2,000 square feet of impervious surface or disturbs more than 7,000 square feet of soil. Projects that disturb fewer than 7,000 square feet of soil must address erosion control and the 12 TESC elements; however, a stand-alone TESC plan is optional and plan sheets are not required. Both the SPCC and TESC plans must be kept on-site or within reasonable access of the site during construction and may require updates with changing site conditions.

To meet the objectives of the permanent stormwater control planning requirements, WSDOT prepares Hydraulic Reports and follows guidelines in the *Maintenance Manual*. The Hydraulic Report provides a complete record of the engineering justification for all drainage modifications and is prepared for all major and minor hydraulic projects based on guidelines in this manual as well as the *Hydraulics Manual*. As noted in the *Hydraulics Manual*, the Hydraulic Report must contain detailed descriptions of the following items:

- Existing and developed site hydrology
- Flow control and runoff treatment systems
- Conveyance system analysis and design
- Wetland hydrology analysis, if applicable
- Downstream analysis, if applicable

3-3.1.3 Guidelines

Instructions on how to prepare SPCC and TESC plans are provided in Minimum Requirement 2 and in Chapter 6.

Stormwater runoff treatment and flow control BMP maintenance criteria for each BMP in Chapter 5 are included in Section 5-5. Additional standards for maintaining stormwater BMPs are found in the *Regional Road Maintenance/Endangered Species Act Program Guidelines* (www.wsdot.wa.gov/maintenance/roadside/esa.htm). The criteria and guidelines are designed to ensure all BMPs function at design performance levels and that the maintenance activities themselves are protective of water quality and its beneficial uses.

3-3.2 Minimum Requirement 2 – Construction Stormwater Pollution Prevention

The two components of construction stormwater pollution prevention are as follows:

- Temporary Erosion and Sediment Control (TESC) planning
- Spill Prevention, Control, and Countermeasures (SPCC) planning

Erosion control is required to prevent erosion from damaging project sites, adjacent properties, and the environment. The emphasis of erosion control is to prevent the erosion process from starting by preserving native vegetation, limiting the amount of bare ground, and protecting slopes. A TESC plan must address the following elements:

- Element 1: Mark clearing limits
- Element 2: Establish construction access
- Element 3: Control flow rates
- Element 4: Install sediment controls
- Element 5: Stabilize soils
- Element 6: Protect slopes
- Element 7: Protect drain inlets
- Element 8: Stabilize channels and outlets
- Element 9: Control pollutants
- Element 10: Control dewatering
- Element 11: Maintain BMPs
- Element 12: Manage the project

All projects that involve mechanized equipment or construction materials that could potentially contaminate stormwater or soils require SPCC plans. The SPCC plan is a stand-alone document prepared by the contractor and contains the following:

- Site information and project description
- Spill prevention and containment
- Spill response
- Material and equipment requirements
- Reporting information
- Program management
- Plans to contain preexisting contamination, if necessary

Detailed requirements for each of these elements are provided in Sections 6-2 and 6-3. The TESC and SPCC plans must (1) demonstrate compliance with all of those detailed requirements, or (2) when site conditions warrant the exemption of an element(s), clearly document in the narrative why a requirement does not apply to the project.

3-3.2.1 Objective

The objective of construction stormwater pollution prevention is to ensure construction projects do not impair water quality by allowing sediment to discharge from the site or allowing pollutant spills.

3-3.2.2 Applicability

All nonexempt projects must address Construction Stormwater Pollution Prevention per Standard Specification 1.07.15(1). All projects that disturb 7,000 square feet or more of land or add 2,000 square feet or more of new, replaced, or new plus replaced impervious surface must prepare a TESC plan in addition to an SPCC plan.

3-3.2.3 Guidelines

Instructions on how to prepare SPCC and TESC plans are provided in Sections 6-2 and 6-3.

3-3.3 Minimum Requirement 3 – Source Control of Pollutants

All known, available, and reasonable source control BMPs must be applied and must be selected, designed, and maintained in accordance with this manual.

3-3.3.1 Objective

The intention of source control is to prevent pollutants from coming into contact and mixing with stormwater. In many cases, it is more cost-effective to apply source control than to remove pollutants after they have mixed with runoff. This is certainly the case for erosion control and spill prevention during the construction phase.

3-3.3.2 Applicability

Minimum Requirement 3 applies to all nonexempt projects that meet the thresholds described in Figure 3.1. Source control (erosion control and spill prevention) applies to all projects during the construction phase per Minimum Requirement 2. Postconstruction source controls are employed programmatically via WSDOT's maintenance program. Thus, in instances where structural BMPs may not be sufficient, consult with the environmental support staff of the HQ Maintenance and Operations Office to explore operational source control options that may be available to meet regulatory requirements.

Certain types of activities and facilities may require source control BMPs. Determine whether there are pollutant-generating activities or facilities in the project that warrant source controls. Source control BMPs for the activities listed in Section 5-2.1 must be specified to reduce pollutants. For detailed descriptions of the source control BMPs, see Chapter 2 of Volume IV of Ecology's *Stormwater Management Manual for Western Washington* (SMMWW) or Chapter 8 of the *Stormwater Management Manual for Eastern Washington* (SMMEW). Any deviations from the source control BMPs listed in either the SMMWW or the SMMEW must provide equivalent pollution source control benefits. The Project File must include documentation for why the deviation is considered equivalent. Section 5-3.5.3 describes the process for seeking approval of such deviations. The project may have additional source control responsibilities as a result of area-specific pollution control plans (such as watershed/basin plans, water cleanup plans, groundwater management plans, or lake management plans), ordinances, and regulations.

3-3.3.3 Guidelines

Source control BMPs include operational and structural BMPs.

- Operational BMPs are nonstructural practices that prevent (or reduce) pollutants from entering stormwater. Examples include preventative maintenance procedures; spill prevention and cleanup; and inspection of potential pollutant sources.
- Structural BMPs are physical, structural, or mechanical devices or facilities intended to prevent pollutants from entering stormwater. Examples include installation of vegetation for temporary and permanent erosion control; putting roofs over outside storage areas; and putting berms around potential pollutant source areas to prevent both stormwater run-on and pollutant run-off.

Many source control BMPs combine operational and structural characteristics. A construction phase example is slope protection using various types of covers: temporary covers (structural) and the active inspection and maintenance needed for effective use of the covers (operational). A postconstruction phase example is street sweeping: a sweeper (mechanical) and the sweeping schedule and procedures for its use (operational) collectively support the BMP.

For criteria on the design of construction-related source control BMPs, see Chapter 6 and Appendix 6A. For criteria on the design of source control BMPs for the postconstruction phase, see Section 5-2.1.

3-3.4 Minimum Requirement 4 – Maintaining the Natural Drainage System

To the maximum extent practicable, natural drainage patterns must be maintained and discharges from the site must occur at the natural outfall locations. The manner by which runoff is discharged must not cause downstream erosion in receiving waters and downgradient properties. Outfalls require dispersal systems and/or energy-dissipation BMPs per *Hydraulics Manual* guidelines.

3-3.4.1 Objective

The intent of maintaining the natural drainage system is to (1) preserve and utilize natural drainage systems to the fullest extent because of the multiple benefits such systems provide, and (2) prevent erosion at, and downstream of, the discharge location.

3-3.4.2 Applicability

Minimum Requirement 4 applies to all nonexempt projects that meet the thresholds described in Figure 3.1, to the maximum extent practicable.

3-3.4.3 Guidelines

When projects affect subsurface and/or surface water drainage, use strategies that minimize impacts and maintain hydrologic continuity. For example, road cuts on hill slopes or roads bisecting wetlands or ephemeral streams can affect subsurface water drainage. Ditching, channel straightening, channel lining, channel obliteration, and roads that bisect wetlands or perennial streams change surface water drainage and stream channel processes. The designer must use the best available design practices to maintain hydrologic function and drainage patterns based on site geology, hydrology, and topography.

If flows for a given outfall are not channeled in the preproject condition, runoff concentrated by the proposed project must be discharged overland through a dispersal system or to surface water through an energy dissipater BMP before leaving the project outfall. Typical *dispersal systems* are rock pads, dispersal trenches, level spreaders, and diffuser pipes. Typical *energy dissipaters* are rock pads and drop structures. These systems are listed in Sections 5-4.3.5 and 5-4.3.6.

In some instances, a diversion of flow from the existing (preproject) discharge location may be beneficial to the downstream properties or receiving water bodies. Examples of where the diversion of flows may be warranted include (1) areas where preproject drainage conditions are contributing to active erosion of a stream channel in a heavily impervious basin, and (2) areas where preproject drainage patterns are exacerbating flooding of downstream properties. If it is determined that a diversion of flow from the natural discharge location may be warranted, contact region or Headquarters hydraulics staff.

3-3.5 Minimum Requirement 5 – Runoff Treatment

Runoff treatment must be provided for all nonexempt projects that meet the threshold described in Figures 3.1, [3.2](#), and [3.3](#).

3-3.5.1 Objective

The purpose of runoff treatment is to reduce pollutant loads and concentrations in stormwater runoff using physical, biological, and chemical removal mechanisms to maintain or enhance beneficial uses of receiving waters. When site conditions are appropriate, infiltration can potentially be the most effective BMP for runoff treatment. Meeting runoff treatment requirements may also be achieved through regional stormwater facilities.

3-3.5.2 Runoff Treatment Exemptions

Any of the runoff treatment exemptions below may be negated by requirements set forth in a Total Maximum Daily Load (TMDL) or a TMDL-related water cleanup plan.

- Runoff treatment is not required where no new pollution-generating impervious surface (PGIS) is added. These include:

- Projects where the only work involved is the addition of paved surfaces not intended for use by motor vehicles (such as sidewalks or bike/pedestrian trails) and that are separated from adjacent roadways.
- Projects where the only work involved is an overlay or upgrade of existing bituminous surface treatment (BST or “chip seal”), asphalt concrete pavement (ACP), or Portland cement concrete pavement (PCCP) without an increase in impervious area. Note: Upgrading a facility from gravel surface to BST, ACP, or PCCP is considered an addition of new impervious surface and is subject to runoff treatment if the thresholds are met.
- Discharges to underground injection control (UIC) facilities may be exempt from basic runoff treatment requirements if the vadose zone matrix between the bottom of the facility and the water table provides adequate treatment capacity (see Section 4-5.4).

3-3.5.3 Applicability²

Minimum Requirement 5 applies to all nonexempt projects that meet the thresholds described in Figures 3.1, 3.2, and 3.3. Even if the threshold is not triggered, runoff from the applicable pollution-generating impervious surfaces (PGIS) and pollution-generating pervious surfaces (PGPS) must be dispersed and infiltrated to adjacent pervious areas when practicable. The extension of the roadway edge and the paving of gravel shoulders and lanes are new PGIS.

Projects not triggering the runoff treatment minimum requirement may still require treatment if a specific deficiency within the project limits is identified through the I-4 Stormwater Retrofit program. The decision to retrofit is made by the project office in collaboration with region and Headquarters program management and environmental services staff.

Natural dispersion areas meeting the requirements of BMP FC.01 must be identified along the project as a part of determining whether the particular TDA exceeds thresholds in Figure 3.3, Step 7. Those effective PGIS areas that are flowing to an existing (preproject) dispersion area can be subtracted as noneffective PGIS.

Equivalent area treatment is allowable for PGIS areas that drain to the same receiving waters and have the same pollutant loading characteristics. While the equivalent area will receive treatment, the new or expanded discharge must not cause a violation of surface water quality standards. Additional information on equivalent area treatment is provided in Section 4-3.6.1.

3-3.5.4 Guidelines

Runoff treatment design involves the following three steps:

² Consult the Glossary for the following key terms: *converted pervious surface*, *impervious surface*, *new PGIS*, *PGPS*, *project limits*, *replaced impervious surface*, *effective PGIS*, *noneffective PGIS*, and *threshold discharge area (TDA)*.

1. Determine the specific runoff treatment requirements (basic treatment, enhanced treatment, oil control, and/or phosphorus control). Refer to *Treatment Targets* below.
2. Choose the method(s) of runoff treatment that will best meet the treatment requirements, taking into account the constraints/opportunities presented by the project's context and operation and maintenance. Refer to Sections 2-5, 2-6, 2-7.4, 4-3.1, 5-3.5, and 5-5.
3. Design runoff treatment facilities based on the sizing criteria. Refer to *Criteria for Sizing Runoff Treatment Facilities* below and Section 5-4.1.

WSDOT's stormwater management design philosophy (see Section 2-5.2) seeks to mimic natural hydrology, where feasible, through the dispersal and infiltration of runoff. The extent to which runoff flow rates and volumes can be (or remain) dispersed and then infiltrated determines the types and sizing of runoff treatment options available. This aspect of runoff treatment planning and design is discussed in detail in Sections 2-3.2, 4-3.6.1, 5-2, and 5-3.

Stormwater facilities are not allowed within a jurisdictional wetland or its natural vegetated buffer, except for conveyance systems allowed by applicable permit(s) or as allowed in a wetland mitigation plan. Wetlands may be considered for runoff treatment if the wetland meets the criteria for hydrologic modification (see Minimum Requirement 6 and Section 4-6 on wetland hydroperiods) and Minimum Requirement 7.

Sections 4-3 (western Washington) and 4-4 (eastern Washington) provide design criteria for sizing runoff treatment facilities, including a description on how to conduct the hydrological analysis to derive treatment volumes and flow rates for treatment facilities. Section 5-4 provides direction on how to design the treatment facilities chosen for the project.

Treatment Targets

There are four runoff treatment targets: *Basic Treatment* (total suspended solids removal), *Enhanced Treatment* (dissolved metals removal), *Oil Control*, and *Phosphorus Control*. Table 3-1 describes applicable treatment targets and performance goals for roadway projects. For nonroadway applications, refer to Ecology's SMMEW or SMMWW. Table 3-2 identifies receiving waters that do not require *Enhanced Treatment* for direct discharges.

Section 5-3.5 provides information on alternative options available to meet each of the four treatment targets. Per Figure 5-3.2, the designer must exhaust all approved runoff treatment BMP options before using a BMP from Section 5-3.5. Treatment facilities, designed in accordance with the design criteria presented in this manual, are presumed to meet the applicable performance goals.

An adopted and implemented Basin Plan, Total Maximum Daily Load (TMDL), or Water Cleanup Plan may also be used to set runoff treatment requirements that are tailored to a

specific basin. However, treatment requirements must not be less than those achieved by facilities designed for Basic Treatment.

Table 3-1. Runoff treatment targets and applications for roadway projects.

Treatment Target	Application	Performance Goal
Basic Treatment	All project threshold discharge areas (TDAs) where runoff treatment threshold is met.	80% removal of total suspended solids (TSS)
Enhanced Treatment (dissolved metals)	Same as for Basic Treatment <u>and does not discharge to Basic Treatment receiving water body AND</u> Roadways within <i>Urban Growth Areas</i> (UGAs) with ADT ¹ <u>≥ 7,500 OR</u> Roadways outside of UGAs with ADT <u>≥ 15,000 OR</u> Required by an adopted basin plan or water cleanup plan/TMDL. (See Table 3-2 for <u>Basic Treatment</u> receiving water <u>bodies</u> .)	Provide a higher rate of removal of dissolved metals than Basic Treatment facilities for influent concentrations ranging from 0.003 to 0.02 mg/L for dissolved copper and 0.02-0.3 mg/L for dissolved zinc
Oil Control	Same as for Basic Treatment AND There is an intersection where either <u>≥15,000 vehicles (ADT) must stop to cross a roadway with ≥25,000 vehicles (ADT) or vice versa² OR</u> Rest areas with an expected <u>trip end count greater than or equal to 300 vehicles per day OR</u> Maintenance facilities that park, store, or maintain 25 or more vehicles (trucks or heavy equipment) that exceed 10 tons gross weight each <u>OR</u> <u>Eastern Washington roadways with ADT >30,000.</u>	No ongoing or recurring visible sheen and 24-hr average total petroleum hydrocarbon concentration of not greater than 10 mg/L with a maximum of 15 mg/L for a discrete (grab) sample
Phosphorus Control	Same as for Basic Treatment AND The project is located in a designated area requiring phosphorus control as prescribed through an adopted basin plan or water cleanup plan/TMDL. ³	50% removal of total phosphorus (TP) for influent concentrations ranging from 0.1 to 0.5 mg/L TP

¹Average daily traffic (ADT) is generally the design year ADT and not the current ADT. A possible exception to this rule is where road ADT would likely never reach levels that would exceed its design capacity (such as with rural portions of the state). Contact region hydraulics staff for more information.

²Treatment is required for these high-use intersections for lanes where vehicles accumulate during the signal cycle, including left- and right-turn lanes from the beginning of the left-turn pocket. If no left-turn pocket exists, the treatable area must begin at a distance equal to three car lengths from the stop line. If runoff from the intersection drains to more than two collection areas that do not combine within the intersection, treatment may be limited to any two of the collection areas where the cars stop.

³Contact region hydraulics or environmental staff to determine whether phosphorus control is required for a project.

Table 3-2. Basic Treatment receiving water bodies.¹

1. All saltwater bodies	
2. Rivers (only Basic Treatment applies below the location)	
Baker (Anderson Creek)	Quillayute (Bogachiel River)
Bogachiel (Bear Creek)	Quinault (Lake Quinault)
Cascade (Marblemount)	Sauk (Clear Creek)
Chehalis (Bunker Creek)	Satsop (Middle and East Fork confluence)
Clearwater (Town of Clearwater)	Similkameen
Columbia (Canadian Border)	Skagit (Cascade River)
Cowlitz (Skate Creek)	Skokomish (Vance Creek)
Elwha (Lake Mills)	Skykomish (Beckler River)
Green (Howard Hanson Dam)	Snake
Grand Ronde	Snohomish (Snoqualmie River)
Hoh (South Fork Hoh River)	Snoqualmie (Middle and North Fork confluence)
Humptulips (West and East Fork confluence)	Sol Duc (Beaver Creek)
Kalama (Italian Creek)	Spokane
Kettle	Stillaguamish (North and South Fork confluence)
Klickitat	North Fork Stillaguamish (Boulder River)
Lewis (Swift Reservoir)	South Fork Stillaguamish (Canyon Creek)
Methow	Suiattle (Darrington)
Moses	Tilton (Bear Canyon Creek)
Muddy (Clear Creek)	Toutle (North and South Fork confluence)
Naches	North Fork Toutle (Green River)
Nisqually (Alder Lake)	Washougal (Washougal)
Nooksack (Glacier Creek)	White (Greenwater River)
South Fork Nooksack (Hutchinson Creek)	Wenatchee
Okanogan	Wind (Carson)
Pend Oreille	Wynoochee (Wishkah River Road Bridge)
Puyallup (Carbon River)	Yakima
Queets (Clearwater River)	
3. Streams with a Strahler order of 4 or higher (as determined using 1:24,000 scale maps to delineate stream order) receiving discharges from roadway outside UGAs with ADT <30,000	
4. Non-fish-bearing streams tributary to Basic Treatment receiving waters	
5. Lakes (county location)	
Banks (Grant)	Silver (Cowlitz)
Chelan (Chelan)	Whatcom (Whatcom)
Moses (Grant)	Washington (King)
Potholes Reservoir (Grant)	Union (King)
Sammamish (King)	
6. Discharges to groundwater via rule-authorized UIC facilities or surface infiltration²	

¹ Receiving waters not requiring Enhanced Treatment for direct discharges (or, indirectly through a municipal storm sewer system). The initial criteria for this list are rivers whose mean annual flow exceeds 1,000 cubic feet per second and lakes whose surface area exceeds 300 acres. Local governments may petition Ecology for the addition of waters to this list, but waters should have sufficient background dilution capacity to accommodate dissolved metals additions from build-out conditions in the watershed under the latest Comprehensive Land Use Plan and zoning regulations.

² Contact region hydraulics or environmental staff to determine whether an underground injection control (UIC) facility is authorized by the rules under the UIC program (WAC 173-218). In western Washington, surface infiltration must meet the soil suitability criteria (SSC-7) when within ¼ mile of surface waters that require the application of Enhanced Treatment. In certain situations, Ecology may approve surface infiltration that would not need enhanced runoff treatment on a case-by-case basis.

Criteria for Sizing Runoff Treatment Facilities

Two sets of criteria exist for sizing runoff treatment facilities—one for western Washington (Table 3-3) and one for eastern Washington (Table 3-4). (See Sections 4-3.1 and 4-4.1 for a detailed discussion of on-line and off-line BMPs.)

Table 3-3. Criteria for sizing runoff treatment facilities in western Washington.

Facility Type	Criteria	Model
Flow-based: upstream of flow control facility (on-line and off-line)	Size treatment facility so that 91% of the annual average runoff will receive treatment at or below the design loading criteria, under postdeveloped conditions for each TDA. If the flow rate is split upstream of the treatment facility, use the off-line flow rates.	Approved continuous simulation model using 15-minute time steps
Flow-based: downstream of flow control facility	Size treatment facility using the full 2-year release rate from the detention facility, under postdeveloped conditions for each TDA.	Approved continuous simulation model using 1-hour time steps
Volume-based (on-line)	<u>Wetpool</u> – Size the wetpool to store the 91 st percentile, 24-hour runoff volume. <u>Other volume based infiltration and filtration facilities</u> – Size the facility to treat 91% of the estimated runoff file for the postdeveloped condition.	Approved continuous simulation model with 1-hour time steps

Table 3-4. Criteria for sizing runoff treatment facilities in eastern Washington.

Facility Type	Criteria	Model
Volume-based	Size facility using the runoff volume predicted for the 6-month, <u>long-duration*</u> storm event under postdeveloped conditions for each TDA.	Single-event model (SCS or SBUH) Climatic Regions 1–4 Regional Storm; OR Type 1A for Climatic Regions 2 & 3 (<u>10-minute time step</u>)
Flow-based: upstream of detention/retention facility	Size facility using the peak flow rate predicted for the 6-month, short-duration storm under postdeveloped conditions for each TDA.	Single-event model (SCS or SBUH) Short-duration storm (<u>5-minute time step</u>)
Flow-based: downstream of detention facility	Size facility using the full 2-year release rate from the detention facility, under postdeveloped conditions for each TDA.	Single-event model (SCS or SBUH) Short-duration storm <u>OR</u> the <u>appropriate long-duration storm</u> depending on the Climate Region, whichever produces the greatest flow

* For more information on long-duration and short-duration storms, see Section 4-4.7.

If runoff from areas other than the total new PGIS and that portion of any replaced PGIS that requires treatment cannot be separated from the total new PGIS runoff, treatment facilities must be sized to treat this additional runoff.

3-3.6 Minimum Requirement 6 – Flow Control

This requirement applies to all nonexempt projects that discharge stormwater directly or indirectly through a conveyance system to a surface freshwater body.

3-3.6.1 Objective

The objective of flow control is to prevent increases in the stream channel erosion rates beyond those characteristic of natural or reestablished conditions. The intent is to prevent cumulative future impacts from increased stormwater runoff volumes and flow rates on streams. Wherever possible, infiltration is the preferred method of flow control. Meeting flow control requirements may also be achieved through regional stormwater facilities.

3-3.6.2 Flow Control Exemptions

Flow control is not required for all discharges to surface waters, because it is not always needed to protect stream morphology. Regardless of whether an exemption applies, projects need to take advantage of on-site opportunities to infiltrate storm runoff to the greatest extent feasible.

The following projects and discharges are exempt from flow control requirements; however, runoff treatment may still be required per Minimum Requirement 5:

1. A project able to disperse stormwater without discharging runoff either directly or indirectly through a conveyance system to surface waters per guidelines in Section 5-2.2.2.
2. Projects discharging stormwater directly or indirectly through a conveyance system into any of the exempt water bodies shown in Table 3-5.
3. Projects discharging stormwater from over-the-water structures such as bridges, docks, and piers in or over fresh water are exempt up to the 2-year flood plain elevation; OR that portion of an over-the-water structure that is over the ordinary high water mark.
4. Portions of a roadway that cut through the 2-year flood plain elevation.
5. Projects discharging stormwater directly or indirectly through a conveyance system into a wetland. However, flow control may still be required to maintain wetland hydrology (depth/duration of inundation) per Minimum Requirement 7. (See other applicable wetland protection criteria under Minimum Requirement 4.)

Any of the exempted areas must meet the following requirements:

- Direct discharge to the exempt receiving water does not result in the diversion of drainage area from perennial streams classified as Types 1, 2, 3, or 4 in the

- State of Washington Interim Water Typing System; or Types “S,” “F,” or “Np” in the Permanent Water Typing System; or from any Category I, II, or III wetland; AND
- Flow-splitting devices or drainage BMPs are applied to route natural runoff volumes from the project site to any downstream Type 5 stream or Category IV wetland:
 - Design of flow-splitting devices or drainage BMPs will be based on continuous hydrologic modeling analysis. The design will assure that flows delivered to Type 5 stream reaches will approximate, but in no case exceed, durations ranging from 50% of the 2-year to the 50-year peak flow.
 - Flow-splitting devices or drainage BMPs that deliver flow to category IV wetlands will also be designed using continuous hydrologic modeling to preserve preproject wetland hydrologic conditions unless specifically waived or exempted by regulatory agencies with permitting jurisdiction; AND
 - The project site must be drained by a conveyance system that is comprised entirely of constructed conveyance elements (such as pipes, ditches, or drainage channels) and that extends to the ordinary high water mark of the exempt receiving water, unless, in order to avoid construction activities in sensitive areas, flows are properly dispersed before reaching the buffer zone of the sensitive or critical area; AND
 - The conveyance system between the project site and the exempt receiving water must have a hydraulic capacity sufficient to convey discharges under future build-out conditions from all project and nonproject areas, if applicable (see the *Utilities Manual*, Section 1-18, for storm drainage requirements), from which runoff is collected; AND
 - Any erodible elements of the constructed conveyance system for the area must be adequately stabilized to prevent erosion under future build-out conditions from areas that contribute flow to the system; AND
 - If the discharge is to a stream that leads to a wetland, or to a wetland that has an outflow to a stream, both this requirement and Minimum Requirement 7 apply.

The following **additional** exemptions (or partial exemptions) are available in eastern Washington:

1. A site with less than 10-inch average annual rainfall that discharges to a seasonal stream that is not connected via surface flow to a nonexempt surface water by runoff generated during the 2-year regional storm for Climatic

- Regions 1–4 OR during the 2-year Type 1A storm for Climatic Regions 2 and 3.
2. Discharges to a stream that flows only during runoff-producing events. The runoff carried by the stream following the 2-year regional storm in Climatic Regions 1–4 OR during the 2-year Type 1A storm for Climatic Regions 2 and 3, must not discharge via surface flow to a nonexempt surface water. The stream may carry runoff during an average annual snowmelt event, but must not have a period of base flow during a year of normal precipitation.
 3. Discharges to stream reaches consisting primarily of irrigation return flows and not providing habitat for fish spawning and rearing. Projects must match the predeveloped 2-year and 25-year peak runoff rates for these discharges. Local irrigation districts may impose other requirements.

Petitions to seek exemptions in additional geographic areas can be submitted to Ecology for consideration. Such a petition must justify the proposed exemption based on a hydrologic analysis demonstrating that the potential stormwater runoff from the exempted area will not significantly increase the erosion forces on the stream channel, nor have near-field impacts. Contact the Region Hydraulics Office to determine the feasibility of potential exemption candidates.

Diversions of flow from perennial streams and from wetlands can be considered if significant existing (preproject) flooding, stream stability, water quality, or aquatic habitat problems would be solved or significantly mitigated by bypassing stormwater runoff, rather than providing stormwater detention and discharge to natural drainage features. Bypassing is not an alternative to applicable flow control or treatment if the flooding, stream stability, water quality, or habitat problem to be solved would be caused by the project. In addition, the proposal must not exacerbate other water quality/quantity problems such as inadequate low flows or inadequate wetland water elevations.

A stormwater engineer or scientist must document the existing problems and their solutions or mitigation as a result of the direct discharge after review of any available drainage reports, basin plans, or other relevant literature. The restrictions in this minimum requirement on conveyance systems that transfer water to exempt receiving waters are applicable in these situations. Approvals by all regulatory authorities with permitting jurisdiction are necessary.

Additional streams in eastern Washington may be exempt by applying the following criteria:

- Any river or stream that is fifth order or greater as determined from a 1:24,000 scale map; OR
- Any river or stream that is fourth order or greater as determined from a 1:100,000 or larger scale map.

Table 3-5. Flow control exempt surface waters list.

Water Body	Upstream Point/Reach for Exemption (if applicable)
Alder Lake	
Asotin Creek	Downstream of confluence with George Creek
Baker Lake	
Baker River	Baker River/Baker Lake downstream of confluence with Noisy Creek
Banks Lake	
Bogachiel River	0.4 miles downstream of Dowans Creek
Bumping Lake	
Bumping River	Downstream of confluence with American River
Calawah River	Downstream of confluence with South Fork Calawah River
Carbon River	Downstream of confluence with South Prairie Creek
Cascade River	Downstream of Found Creek
Cedar River	Downstream of confluence with Taylor Creek
Chehalis River	1,500 feet downstream of confluence with Stowe Creek
Chehalis River, South Fork	1,000 feet upstream of confluence with Lake Creek
Cispus River	Downstream of confluence with Cat Creek
Clearwater River	Downstream of confluence with Christmas Creek
Cle Elum River	Downstream of Cle Elum Lake
Columbia River	Downstream of Canadian border
Columbia River Reservoirs	
Colville River	Downstream of confluence with Chewelah Creek
Conconully Reservoir	
Coweman River	Downstream of confluence with Gobble Creek
Cowlitz River	Downstream of confluence of Ohanapecosh River and Clear Fork Cowlitz River
Crescent Lake	
Dickey River	Downstream of confluence with Coal Creek
Dosewallips River	Downstream of confluence with Rocky Brook
Dungeness River, main channels	Downstream of confluence with Gray Wolf River
Elwha River	Downstream of confluence with Goldie River
Grande Ronde River	Entire reach from the Oregon to Idaho border
Grays River	Downstream of confluence with Hull Creek
Green River (WRIA 26 – Cowlitz)	3.5 miles upstream of Devils Creek
Hoh River	1.2 miles downstream of Jackson Creek
Humptulips River	Downstream of confluence with West and East Forks
Kalama River	2.0 miles downstream of Jacks Creek
Kettle River	Downstream of confluence with Boulder Creek
Klickitat River	Downstream of confluence with West Fork
Latah Creek (formerly Hangman Creek)	Downstream of confluence with Rock Creek (in Spokane County)
Lake Chelan	
Lake Cle Elum	
Lake Cushman	
Lake Kachess	
Lake Keechelus	
Lake Quinault	
Lake Shannon	
Lake Sammamish	
Lake Union	King County

Water Body	Upstream Point/Reach for Exemption (if applicable)
Lake Wenatchee	
Lake Washington	
Lake Whatcom	
Lewis River	Downstream of confluence with Quartz Creek
Lewis River, East Fork	Downstream of confluence with Big Tree Creek
Lightning Creek	Downstream of confluence with Three Fools Creek
Little Spokane River	Downstream of confluence with Deadman Creek
Little White Salmon River	Downstream of confluence with Lava Creek
Lower Crab Creek	Entire reach
Mayfield Lake	
Methow River	Downstream of confluence with Early Winters Creek
Moses Lake	
Muddy River	Downstream of confluence with Clear Creek
Naches River	Downstream of confluence with Bumping River
Naselle River	Downstream of confluence with Johnson Creek
Newaukum River	Downstream of confluence with South Fork Newaukum River
Nisqually River	Downstream of confluence with Big Creek
Nooksack River	Downstream of confluence of North and Middle Forks
Nooksack River, North Fork	Downstream of confluence with Glacier Creek, at USGS gage 12205000
Nooksack River, South Fork	0.1 miles upstream of confluence with Skookum Creek
North River	Downstream of confluence with Vesta Creek
Ohanapecosh River	Downstream of confluence with Summit Creek
Okanogan River	Downstream of Canadian border
Osoyoos Lake	
Pacific Ocean	
Palouse River	Downstream of confluence with South Fork Palouse River
Pend Oreille River	Idaho to Canadian border
Pend Oreille River Reservoirs	
Pothole Reservoir	
Puget Sound	
Puyallup River	Half-mile downstream of confluence with Kellog Creek
Queets River	Downstream of confluence with Tshletshy Creek
Quillayute River	Downstream of Bogachiel River
Quinalt River	Downstream of confluence with North Fork Quinalt River
Riffe Lake	
Rimrock Lake	
Rock Creek	In Whitman County, downstream of confluence with Cottonwood Creek
Ruby Creek	Ruby Creek at State Route 20 crossing downstream of Granite and Canyon Creeks
Sammamish River	Downstream of Lake Sammamish
Sauk River	Downstream of confluence of North and South Forks
Satsop River	Downstream of confluence of Middle and East Forks
Satsop River, East Fork	Downstream of confluence with Decker Creek
Silver Lake	Cowlitz County
Similkameen River	Downstream of Canadian border
Skagit River	Downstream of Canadian border
Skokomish River	Downstream of confluence of North and South Forks
Skokomish River, South Fork	Downstream of confluence with Vance Creek

Water Body	Upstream Point/Reach for Exemption (if applicable)
Skokomish River, North Fork	Downstream of confluence with McTaggart Creek
Skookumchuck River	1 mile upstream of Bucoda at State Route 507, milepost 11.0
Skykomish River	Downstream of South Fork
Skykomish River, South Fork	Downstream of confluence of Tye and Foss Rivers
Snake River	Entire reach along Idaho boarder to the Columbia River
Snake River Reservoirs	
Snohomish River	Downstream of confluence of Snoqualmie and Skykomish Rivers
Snoqualmie River	Downstream of confluence of the Middle Fork
Snoqualmie River, Middle Fork	Downstream of confluence with Rainy Creek
Sol Duc River	Downstream of confluence of North and South Fork Soleduck River
Spokane River	Downstream of Idaho border
Spokane River Reservoirs	
Stillaguamish River	Downstream of confluence of North and South Forks
Stillaguamish River, North Fork	7.7 highway miles west of Darrington on State Route 530, downstream of confluence with French Creek
Stillaguamish River, South Fork	Downstream of confluence of Cranberry Creek and South Fork
Suiattle River	Downstream of confluence with Milk Creek
Sultan River	0.4 miles upstream of State Route 2
Swift Creek Reservoir	
Teanaway River	Downstream of confluence of North and West Forks
Thunder Creek	Downstream of confluence with Neve Creek
Tieton River	Downstream of Rimrock Lake
Tilton River	Downstream of confluence with North Fork Tilton River
Toppenish Creek	Downstream of confluence with Wanity Slough
Touchet River	Downstream of confluence with Patit Creek
Toutle River	North and South Fork confluence
Toutle River, North Fork	Downstream of confluence with Hoffstadt Creek
Toutle River, South Fork	Downstream of confluence with Thirteen Creek
Tucannon River	Downstream of confluence with Pataha Creek
Walla Walla River	Downstream of confluence with Mill Creek
Wenatchee River	Downstream of confluence with Icicle Creek
White River	Downstream of confluence with Huckleberry Creek
White Salmon River	0.15 miles upstream of confluence with Trout Lake Creek
Willapa River	Downstream of confluence with Mill Creek
Wind River	Downstream of confluence with Cold Creek
Wynoochee Lake	
Wynoochee River	Downstream of confluence with Schafer Creek
Yakima River	Downstream of Lake Easton

3-3.6.3 Applicability³

Minimum Requirement 6 applies to all nonexempt projects that meet the thresholds described in Figures 3.1, 3.2, and 3.3. The threshold for triggering the flow control requirement takes into account the project's effective impervious surfaces and converted pervious surfaces.

³ Consult the Glossary for the following key terms: *converted pervious surface*, *new impervious surface*, *effective impervious surface*, *net-new impervious surface*, *project limits*, *replaced impervious surface*, and *threshold discharge area (TDA)*.

Application of the “net-new impervious surface” concept only applies to Minimum Requirement 6 at the TDA level (Figure 3.3, Step 8). Application of the concept does not extend to any other minimum requirement. When applying the net-new impervious approach, the pavement permanently removed by the project needs to be reverted to a pervious condition per the guidelines in Section 4-3.6.1.

Natural dispersion areas meeting the requirements of BMP FC.01 must be identified within the project limits as a part of determining whether the particular TDA exceeds thresholds in Figure 3.3, Step 8. Those effective impervious surface areas that are flowing to an existing (preproject) dispersion area can be subtracted as noneffective impervious surfaces.

The analysis for Step 8 in Figure 3.3 is based on preproject (what is currently seen at the project site) land cover conditions for the predeveloped modeling condition and the postconstruction (after the project is completed) land cover conditions for the developed modeling conditions. When using the Single Scaling Factor Approach (called “Station Data” option in MGSFlood) to perform this analysis, contact the HQ Hydraulics Office, since the data station may not be able to produce the 100-year flow due to insufficient rainfall data. Refer to Section 4 of the MGSFlood User’s Manual for additional information on the Single Scaling Factor Approach: www.wsdot.wa.gov/Design/Hydraulics/Training.htm

3-3.6.4 Guidelines

Infiltration is the preferred method to control flow. If infiltration cannot be achieved at the project site, refer to the appropriate design criteria listed below and in Chapter 4.

Flow control BMPs or the live storage portion of a combination flow control/runoff treatment BMP must not be placed below the seasonal high water table. As an alternative, first look for equivalent areas within the same threshold discharge area (TDA) to provide the necessary flow control. If a feasible location cannot be found within the TDA, seek out equivalent areas—within WSDOT right of way—upstream of the TDA that discharges to the same receiving water body to provide the necessary flow control. Lastly, if a feasible location cannot be found upstream of the TDA, seek out equivalent areas—within WSDOT right of way—downstream of the TDA that discharges to the same receiving water body to provide the necessary flow control. Document these constraints using the Engineering and Economic Feasibility (EEF) Evaluation Checklist (Appendix 2A).

If none of the above options is feasible within the project site, then explore alternative flow control mitigation in the watershed (for example, purchasing land and converting it back to a forested condition or restoring wetlands in close proximity to the project site). Refer to Section 2-7.3 for more information on watershed-based approaches.

Avoid placing BMPs in wetlands, 100-year floodplains, and intertidal areas. These natural systems have a higher net environmental benefit than engineered stormwater management systems. If the placement of a required flow control BMP would impact such a sensitive area, consult the Region Hydraulics Office as early as possible for aid in properly analyzing

the effects of various flow control options. The Region Hydraulics and Environmental offices will also coordinate with the appropriate state, local, tribal, and federal agencies to ensure adequate protection of all natural resources.

Design specifications for conveyance and flood prevention are reviewed with the assistance of the Region or HQ Hydraulics Office.

Western Washington Design Criteria

Stormwater discharges must match developed discharge durations to predeveloped durations for the range of predeveloped discharge rates from 50% of the 2-year peak flow up to the full 50-year peak flow. Also, check the 100-year peak flow rate for downstream flooding and property damage using an approved continuous simulation model.

Refer to Section 4-3.6.1 for the appropriate modeling process. Also, reference the same section for the modeling process to address mitigated and nonmitigated areas on projects in on-site and off-site flow bypass situations.

Predeveloped Condition for Stormwater Hydrology Modeling

The project site's predeveloped conditions are to assume "forested" land cover conditions unless one of the following conditions applies:

- Reasonable, historic information is provided that indicates the site was prairie prior to settlement (modeled as "pasture" in MGSFlood).
- The drainage area of the immediate stream and all subsequent downstream basins has had at least 40% total impervious area since 1985. In this case the predeveloped condition to be matched must be the existing land cover condition. Where basin-specific studies determine a stream channel to be unstable, even though the above criterion is met, the predeveloped condition assumption must be the "historic" land cover condition or a land cover condition commensurate with achieving a target flow regime identified by an approved basin study. More information on qualifying basins is available at: www.ecy.wa.gov/programs/wq/stormwater/flow_control.html

For WSDOT projects, the designer can assume an existing land cover condition if following the Stormwater Retrofit Analysis procedure outlined in Section 3-4 and Figure 3-4. This process was created through an agreement between WSDOT and DOE for WSDOT projects.

Table 3-6 summarizes flow control criteria for western Washington. The duration standard does not apply to infiltration facilities that will reliably infiltrate all the runoff from impervious surfaces and converted pervious surfaces.

Table 3-6. Western Washington flow control criteria.

Facility Type	Criteria	Model
Detention/combination treatment and detention facilities	Provide storage volume required to match the duration of predeveloped peak flows from 50% of the 2-year up to the 50-year storm flow, using a flow restrictor (such as an orifice or weir), and check the 100-year peak flow for property damage.	Continuous simulation model using 1-hour time steps
Infiltration facilities	Size facility to infiltrate sufficient volumes so that the overflow matches the duration standard, and check the 100-year peak flow <u>to estimate the potential for downstream property damage, or infiltrate the entire runoff file.</u>	Continuous simulation model using 1-hour time steps

An alternative flow control standard may be established through applying watershed-scale hydrologic modeling and supporting field observations. Possible justifications for an alternative flow control standard include:

1. Establishment of a stream-specific threshold of significant bedload movement other than the assumed 50% of the 2-year peak flow; OR
2. Zoning and Land Clearing Ordinance restrictions that, in combination with an alternative flow control standard, maintain or reduce the naturally occurring erosive forces on the stream channel, with local jurisdiction approval; OR
3. A duration control standard is not necessary for protection, maintenance, or restoration of designated beneficial uses or Clean Water Act compliance.

Eastern Washington Design Criteria

Using a single-event model, flow control design requirements for projects must limit the peak release rate of the postdeveloped 2-year runoff volume to 50% of the predeveloped 2-year peak and maintain the predeveloped 25-year peak runoff rate. The 100-year event must be checked for downstream flooding and property damage.

Predeveloped Condition for Stormwater Hydrology Modeling

The project site's predeveloped conditions are to assume an existing land cover. Table 3-7 summarizes flow control criteria for eastern Washington. The peak flow matching standard does not apply to infiltration facilities that will reliably infiltrate all the runoff from impervious surfaces and converted pervious surfaces.

Table 3-7. Eastern Washington flow control criteria.

Facility Type	Criteria	Model
Detention/combination treatment and detention facilities	Provide storage volume required to match ½ of the 2-year predeveloped peak flow rate, match the predeveloped 25-year peak flow rate, and check the 100-year peak flow for property damage.	Single-event model (SCS or SBUH) Climatic Regions 1–4 Regional Storm; OR Type 1A Storm for Climatic Regions 2 & 3 only
Infiltration facilities	Size facility to infiltrate <u>sufficient runoff</u> volumes that <u>the overflow does not exceed the 25-year peak flow requirement</u> . Check the 100-year peak flow <u>to estimate the potential for downstream property damage</u> , or infiltrate <u>the entire runoff file</u> .	Single-event model (SCS or SBUH) Climatic Regions 1–4 Regional Storm; OR Type 1A Storm for Climatic Regions 2 & 3 only

Predevelopment and postdevelopment runoff volumes and flow rates must be estimated in accordance with Table 3-7 and Section 4-4.2 using the Regional Storm for Climatic Regions 1–4; OR Type 1A Storm for Climatic Regions 2 and 3.

In some instances, the 2-year predeveloped flow rate is zero cubic feet per second or the flow rate is so small that it is impracticable to design a pond to release at the prescribed flow rate from an engineered outlet structure. In these cases, the total postdeveloped 2-year storm runoff volume must be infiltrated (preferred) or stored in a retention pond for evaporation and the detention pond designed to release the predeveloped 10- and 25-year flow rates. (See BMP FC.03, Detention Pond, in Section 5-4.2.3 for pond and release structure design information.)

Infiltration facilities for flow control must be designed based on postdeveloped runoff volumes, and must be designed to infiltrate the entire volume of the criteria noted in Table 3-7. If full infiltration is not possible, all surface discharges must match the following criteria:

- If the 2-year postdeveloped outflow volume discharged to a surface water and is less than or equal to the 2-year predeveloped outflow volume, then the postdeveloped 2-year flow rate must be less than or equal to the 2-year predeveloped flow rates. The flows for the 25- and 100-year events must meet the criteria in Table 3-7, row 1.
- If the 2-year postdeveloped outflow volume is greater than the 2-year predeveloped outflow volume, then all surface water discharges must match the flow rate standards in Table 3-7, row 1.

The justification from Ecology for matching one-half the preexisting flow rate is the added work done on the natural channel by the excess volume released in a typical “detention/retention” pond system. If infiltration disposes of the extra volume produced by the added

impervious areas, then releasing flow at the preexisting 2-year rate mimics the existing hydrologic conditions.

3-3.7 Minimum Requirement 7 – Wetlands Protection

Stormwater discharges to wetlands must maintain the wetland's hydrologic conditions (particularly hydroperiod), hydrophytic vegetation, and substrate characteristics that are necessary to maintain existing wetland functions and values.

3-3.7.1 Objective

The objective of wetlands protection is to ensure wetlands receive the same level of protection as any other waters of the state.

3-3.7.2 Applicability

Minimum Requirement 7 applies to all nonexempt projects that meet the thresholds described in Figure 3.1 and where stormwater discharges into a wetland, either directly or indirectly, through a conveyance system.

All stormwater discharges to wetlands must comply with this manual's runoff treatment requirements.

3-3.7.3 Guidelines

Steps must be taken during design to maximize natural water storage and infiltration opportunities within the project site and outside existing wetlands. Natural wetlands may not be used as pollution control facilities in lieu of runoff treatment BMPs.

Building stormwater runoff treatment and flow control facilities within a wetland or its natural vegetated buffer is discouraged, except for:

- Necessary conveyance systems as allowed by applicable permit(s); OR
- As allowed in wetlands approved for hydrologic modification or treatment in accordance with Ecology guidance. For western Washington projects, refer to *Guide Sheet 1B* in Appendix I-D of Ecology's SMMWW. For eastern Washington projects, refer to *Use of Existing Wetlands to Provide Runoff Treatment* (in Section 2.2.5) and *Application to Wetlands and Lakes* (in Section 2.2.6) in Ecology's SMMEW, and the *Eastern Washington Wetland Rating Form*: www.wsdot.wa.gov/NR/rdonlyres/41520679-F96D-47A9-9B70-3EE8BBEC391F/0/WetlandRatingForm_EasternWA.doc; OR
- Projects with approved permits from the appropriate resource agencies.

An adopted and implemented basin plan (see Minimum Requirement 8), or a Total Maximum Daily Load (TMDL) Water Cleanup Plan may be used to develop requirements for wetlands that are tailored to a specific basin.

The thresholds identified in Minimum Requirement 5 (Runoff Treatment) and Minimum Requirement 6 (Flow Control) must also be applied for discharges to wetlands. In addition, a hydroperiod analysis must be performed and must show that the discharge will not adversely affect the wetland hydroperiod.

When considering constructing new wetlands or using existing wetlands for flow control or runoff treatment, or when looking for guidelines on protecting wetlands from stormwater impacts, seek input from the appropriate in-house experts in the environmental, biological, wetlands, and landscape architectural disciplines. For projects in the Puget Sound basin, refer to *Guide Sheet 2B* in Appendix I-D of Ecology's SMMWW. Refer to Section 2-6.1.1 regarding special wetland design considerations, Section 4-6 for additional information on wetland hydroperiod analysis, and Section 5-4.1.4 for additional information on the Constructed Stormwater Treatment Wetland (see BMP RT.13).

3-3.8 Minimum Requirement 8 – Incorporating Watershed/Basin Planning Into Stormwater Management

Watershed/basin plans may subject projects to different minimum requirements for erosion control; source control; runoff treatment; and operation and maintenance; and to alternative requirements for flow control and wetlands hydrologic control. Watershed/basin plans must evaluate and include, as necessary, retrofitting urban stormwater BMPs into existing development or redevelopment in order to achieve watershed-wide pollutant reduction and flow control goals consistent with the requirements of the federal Clean Water Act. Standards developed from basin plans cannot modify any of the above minimum requirements until the basin plan is formally adopted and implemented by the local governments within the basin and has received approval or concurrence from Ecology.

3-3.8.1 Objective

The objective of incorporating watershed-based/basin planning into stormwater management is to promote the development of watershed-based resource plans as a means to develop and implement comprehensive water resource protection measures. The primary objective of basin planning is to reduce pollutant loads and hydrologic impacts to surface waters and groundwaters in order to protect water resources.

3-3.8.2 Applicability

Minimum Requirement 8 applies where watershed and basin plans are in effect for all nonexempt projects that meet the thresholds described in Figure 3.1.

3-3.8.3 Guidelines

While Minimum Requirements 1 through 7 establish general standards for individual sites, they do not evaluate the overall pollution impacts and protection opportunities that could exist at a watershed scale. For a basin plan to serve as a means of modifying the minimum requirements, the following conditions must be met:

- The plan must be formally adopted by all jurisdictions with implementation responsibilities under the plan; AND
- All ordinances or regulations called for by the plan must be in effect.

Basin planning provides a mechanism by which the minimum requirements and implementing BMPs can be evaluated and refined based on an analysis of an entire watershed. Basin plans are especially well suited for developing control strategies to address impacts from future development and to correct specific problems whose sources are known or suspected. Basin plans can be effective in addressing both long-term and cumulative impacts of pollutant loads; short-term acute impacts of pollutant concentrations; and hydrologic impacts to streams, wetlands, and groundwater resources. (See Section 2-7.3 for further guidelines on basin/watershed planning.) Refer to Appendix I-A of Ecology's SMMWW for examples of how basin planning can alter the minimum requirements of this manual.

3-3.9 Minimum Requirement 9 – Operation and Maintenance

An operation and maintenance manual that is consistent with the criteria in Section 5-5 will be provided for all proposed stormwater facilities and BMPs. The party (or parties) responsible for such maintenance and operation must be identified and a record of maintenance activities kept.

3-3.9.1 Objective

The objective of operation and maintenance is to achieve appropriate preventive maintenance and performance checks to ensure stormwater control facilities are adequately maintained and properly operated to:

- Remove pollutants and/or control flows as designed.
- Permit the maximum use of the roadway.
- Prevent damage to the highway structure.
- Protect natural resources.
- Protect abutting property from physical damage.

3-3.9.2 Applicability

Minimum Requirement 9 applies to all projects that require stormwater control facilities or BMPs and is accomplished programmatically via WSDOT's maintenance program.

3-3.9.3 Guidelines

Inadequate maintenance is a common cause of stormwater management facility degraded performance or failure. Section 5-5 provides criteria for BMP maintenance. The *Maintenance Manual* provides further guidelines on stormwater management-related operation and maintenance activities.

3-4 Stormwater Retrofit Guidelines

This section provides guidelines to assess (1) whether project-driven stormwater retrofit obligations can be met off-site by retrofitting an equivalent area of state highway in targeted environmental priority locations (see Figure 3.4 for Stormwater Retrofit Analysis for projects), and (2) whether it is cost-effective to provide stormwater management retrofits beyond what are called for under these requirements. This section also provides guidelines for the documentation and recording of any project-related stormwater retrofit activity. Following are the five general cases where a stormwater retrofit might occur:

1. Where WSDOT can retrofit existing impervious surfaces
2. Where a stand-alone high-priority stormwater retrofit project is already scoped and funded and is within the project limits
3. Where a TDA does not provide all the required flow control for replaced impervious surfaces after providing as much flow control as possible on the project site
4. Where a TDA does not provide all the required runoff treatment for replaced pollution-generating impervious surfaces (PGIS) after providing as much runoff treatment as possible on the project site
5. Where the project provides flow control to predeveloped "existing land cover" conditions

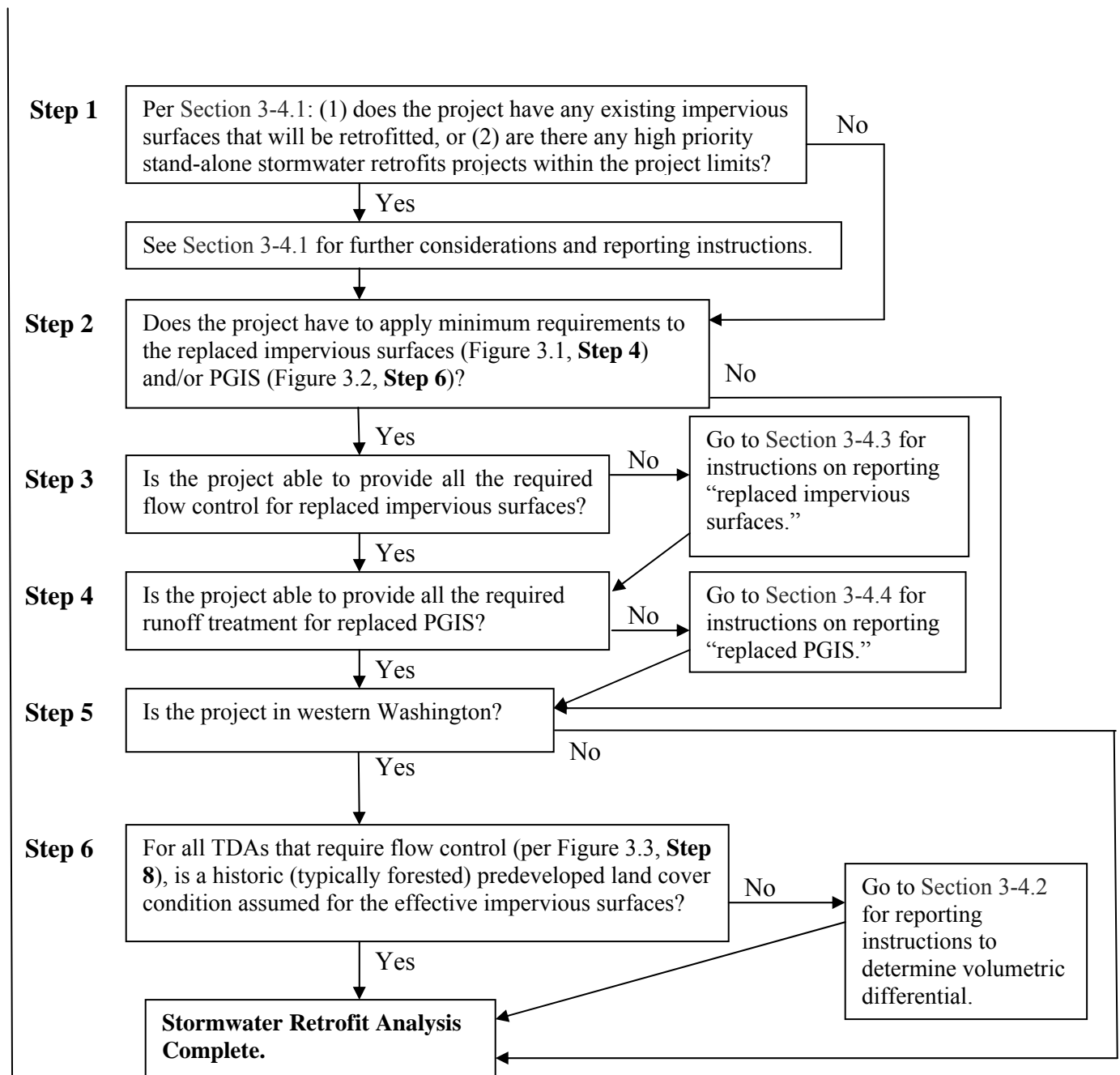

Figure 3.4 Stormwater Retrofit Analysis for WSDOT projects.

3-4.1 Retrofitting Existing Impervious Surfaces and Stand-Alone Priority Stormwater Retrofit Projects

3-4.1.1 Existing Impervious Surfaces

As described in Section 1-2.3, the ultimate goal is to provide practicable stormwater management for runoff from existing impervious surfaces that do not have treatment or flow control or for which treatment or flow control is substandard. As designers scope (or revise the scope of) affected projects, they will need to determine whether it is cost-effective to provide stormwater management retrofits beyond what is called for under the HRM's minimum requirements. In making this decision, WSDOT needs to follow an approach that ensures it does not circumvent the Legislature's authority to determine where to invest financial resources. At the same time, the department's goal is to retrofit existing impervious surfaces where a significant amount of pavement is added on a project.

WSDOT has adopted a departmental budget structure with a specific category for retrofitting existing impervious surfaces in order to meet one of the requirements of WAC 173-270-060. This budget structure allows the department to include the work from one project category in another category if it does not add significant cost to the project. In accordance with this guideline, the HQ Strategic Planning and Programming Office has established the following guidelines when making decisions about adding stormwater retrofits of existing impervious surfaces into new improvement and preservation projects:

1. Mobility projects (I-1 subprogram) can always consider including the cost of retrofitting existing impervious surfaces.
2. Safety projects (I-2 subprogram) can include the retrofitting of existing impervious surfaces only if the cost to retrofit all existing impervious surfaces does not exceed an additional 20% of the cost of treating new impervious surfaces. The region may request a variance from this limit for extenuating circumstances.
3. Economic Initiatives (I-3 subprogram, *except for* Four-Lane Trunk projects) can include the retrofitting of existing impervious surfaces only if the cost to retrofit all existing impervious surfaces does not exceed an additional 20% of the cost of treating new impervious surfaces. The region may request a variance from this limit for extenuating circumstances.
4. Four-Lane Trunk projects in the I-3 subprogram can always consider including the retrofitting of existing impervious surfaces.
5. Environmental Retrofit projects (I-4 subprogram, *except for* the Stormwater Retrofit category) do not add new impervious surfaces and cannot retrofit existing impervious surfaces. The region may request a variance from this limit for extenuating circumstances.

6. For those safety and economic initiative projects that exceed the 20% limit, and where the HQ Project Control and Reporting Office and region concur, the region can submit a request for funding from the I-4 Stormwater Retrofit category. These requests will be prioritized with the other stormwater retrofit needs already identified for funding by the Legislature.
7. Paving projects (P-1 subprogram) can only consider retrofitting existing impervious surfaces for projects involving the total replacement of existing concrete lanes. On projects that only replace the existing asphalt shoulder with concrete, retrofitting is not required.

Questions on applying the above guidelines should be directed through the Region Program Management Office, with backup (if needed) to the HQ Strategic Planning and Programming Systems' Analysis and Program Development Office. Finally, budget implications and Ecology-approved basin plan status must be considered prior to including retrofit as part of a project's scope.

Associated costs for providing flow control for all the runoff from new, replaced, and existing impervious areas must be recorded in the project's Hydraulic Report. The extent and type of any stormwater retrofit activity needs to be documented in the Hydraulic Report and the Stormwater Design Documentation Spreadsheet at:

www.wsdot.wa.gov/Environment/WaterQuality/Runoff/HighwayRunoffManual.htm

3-4.1.2 I-4 Subprogram Environmental Retrofit Stormwater Projects

I-4 subprogram environmental retrofit stormwater projects located within the project limits must be evaluated for incorporation by the project office.

3-4.2 Effective Impervious Surface in Western Washington

For every TDA that requires flow control per Figure 3.3, Step 8, the predeveloped conditions for the effective impervious surfaces need to be examined. Where the predeveloped condition for the effective impervious surfaces is considered to be an "existing land cover" (usually pasture or grass) and not assumed to be a "historic land cover," a flow control volumetric difference needs to be determined and documented between the two conditions.

Using MGSFlood or other Ecology-approved continuous simulation model, the designer should perform two analyses to determine the required flow control volumes for the two different predeveloped conditions in the TDA. Subtracting the two volumes will give the volumetric difference between using "existing land cover" conditions and "historic land cover" conditions for the TDA. This number needs to be recorded as part of the Stormwater Retrofit Analysis. The designer must record the quantity in cubic feet on the Stormwater Design Documentation Spreadsheet at:

www.wsdot.wa.gov/Environment/WaterQuality/Runoff/HighwayRunoffManual.htm

3-4.3 Replaced Impervious Surface

If thresholds in Figure 3.1, Step 4, are exceeded and for each TDA that exceeds thresholds in Figure 3.3, Step 8, after providing as much flow control as possible on the project site, the designer must record the amount of replaced impervious surface that does not receive flow control. The designer must record quantities by using the Stormwater Design Documentation Spreadsheet at:

www.wsdot.wa.gov/Environment/WaterQuality/Runoff/HighwayRunoffManual.htm. The area must be recorded to the nearest tenth of an acre.

3-4.4 Replaced PGIS

If thresholds in Figure 3.2, Step 6, are exceeded and for each TDA that exceeds thresholds in Figure 3.3, Step 7, after providing as much runoff treatment as possible on the project site, the designer must record the amount of replaced PGIS that does not receive runoff treatment. Designers must record quantities using the Stormwater Design Documentation Spreadsheet at: www.wsdot.wa.gov/Environment/WaterQuality/Runoff/HighwayRunoffManual.htm. The area must be recorded to the nearest tenth of an acre. The type of treatment needed in the TDA must also be recorded along with the TDA's projected ADT and other information supporting the required runoff treatment type (basic, enhanced, phosphorous control, and/or oil control).

The extent and type of any stormwater retrofit activity needs to be documented in the Hydraulic Report and the Stormwater Design Documentation Spreadsheet at:

www.wsdot.wa.gov/Environment/WaterQuality/Runoff/HighwayRunoffManual.htm

CHAPTER 4

Hydrologic Analysis

Chapter 4. Table of Contents

Chapter 4.	Hydrologic Analysis.....	4-1
4-1	Introduction	4-1
4-2	Project Considerations.....	4-2
4-2.1	Estimating Stormwater Management Areas	4-2
4-2.2	Local and State Requirements.....	4-2
4-2.3	Soils.....	4-3
4-2.4	Determining Existing Conditions.....	4-3
4-2.5	Mapping Threshold Discharge Areas	4-3
4-2.6	Conclusions.....	4-6
4-3	Western Washington Design Criteria.....	4-9
4-3.1	Runoff Treatment Flow-Based and Volume-Based BMPs.....	4-9
4-3.1.1	Flow-Based Runoff Treatment	4-9
4-3.1.2	Volume-Based Runoff Treatment	4-11
4-3.2	Flow Control Volume and Flow Duration-Based BMPs	4-12
4-3.3	Temporary Construction Site Erosion and Sediment Control	4-12
4-3.4	Exemptions for Flow Control	4-12
4-3.5	Hydrologic Analysis Methods for Designing BMPs in Western Washington: HSPF versus SBUH.....	4-13
4-3.5.1	Hydrologic Analysis for Runoff Treatment.....	4-13
4-3.5.2	Hydrologic Analysis for Flow Control.....	4-13
4-3.6	Hydrologic Analysis Methods for Flow Control and Runoff Treatment Facility Design.....	4-15
4-3.6.1	Continuous Simulation Method.....	4-15
4-4	Eastern Washington Design Criteria	4-29
4-4.1	Runoff Treatment Flow-Based and Volume-Based BMPs.....	4-30
4-4.1.1	Flow-Based Runoff Treatment	4-30
4-4.1.2	Volume-Based Runoff Treatment	4-30
4-4.2	Flow Control BMPs	4-31
4-4.3	Temporary Construction Site Erosion and Sediment Control	4-31
4-4.4	Exemptions for Flow Control	4-31
4-4.5	Hydrologic Analysis Methods for Flow Control and Runoff Treatment Facility Design.....	4-31
4-4.6	Single-Event Hydrograph Method	4-34
4-4.6.1	Design Storm Hyetograph	4-35
4-4.6.2	Runoff Parameters	4-35
4-4.6.3	Hydrograph Synthesis.....	4-39
4-4.6.4	Level Pool Routing.....	4-40
4-4.6.5	Hydrograph Summation	4-41
4-4.7	Eastern Washington Design Storm Events	4-41
4-4.8	Modeling Using Low-Impact Development Techniques in Eastern Washington	4-42

4-5	Infiltration Design Criteria	4-44
4-5.1	Site Suitability Criteria (SSC).....	4-45
4-5.2	Saturated Hydraulic Conductivity.....	4-49
4-5.2.1	Detailed Approach to Determine Saturated Hydraulic Conductivity	4-49
4-5.2.2	Determining Saturated Hydraulic Conductivity Using the Guelph Permeameter	4-52
4-5.3	Determination of Infiltration Rates	4-53
4-5.3.1	Detailed Approach for Determining Infiltration Rates.....	4-53
4-5.3.2	Simplified Approach to Determining Infiltration Rates.....	4-62
4-5.3.3	Determining Infiltration Rates for Soil Amendment BMPs.....	4-67
4-5.4	Underground Injection Facilities	4-70
4-5.4.1	Design Procedure for Infiltration Trenches	4-76
4-5.4.2	Design Procedure for Drywells	4-78
4-6	Wetland Hydroperiods	4-80
4-7	Closed Depression Analysis.....	4-80
4-7.1	Analysis and Design Criteria	4-80
4-7.2	Western Washington Method of Analysis	4-81
4-7.3	Eastern Washington Methods of Analysis.....	4-82
4-8	References	4-84

Appendix 4A. Web Links

Appendix 4B. TR55 Curve Number Tables

Appendix 4C. Eastern Washington Design Storm Events

List of Tables

Table 4-1. Pervious land cover/soil type combinations used with HSPF model parameters.	4-15
Table 4-2. Relationship between NRCS hydrologic soil group and HSPF soil group.	4-23
Table 4-3. Flow control modeling techniques based on land use.	4-25
Table 4-4. Flow control modeling techniques for the interim.	4-25
Table 4-5. Characteristics of detention and infiltration ponds sized using MGSFlood optimization routine.	4-28
Table 4-6. Total 5-day antecedent rainfall (inches).	4-38
Table 4-7. Infiltration rate reduction factors to account for biofouling and siltation effects for ponds (Massmann, 2003).	4-60
Table 4-8. Recommended infiltration rates based on ASTM Gradation Testing.	4-63
Table 4-9. Treatment capacity class based on vadose zone properties.	4-73
Table 4-10. Stormwater pollutant loading classifications for UIC facilities receiving stormwater runoff.	4-74
Table 4-11. Matrix for determining pretreatment requirements.	4-75
Table 4-12. Infiltration rate reduction factors to account for biofouling and siltation effects for trenches (Massmann, 2003).	4-78

List of Figures

Figure 4-1.	Drainage basin delineation example.....	4-4
Figure 4-2a.	Threshold discharge areas (plan – not to scale).	4-5
Figure 4-2b.	Threshold discharge areas (plan – not to scale).	4-5
Figure 4-3.	Threshold discharge areas (section and profile).....	4-6
Figure 4-4.	Hydrologic analysis flowchart for western Washington.	4-7
Figure 4-5.	Hydrologic analysis flowchart for eastern Washington.	4-8
Figure 4-6.	Typical on-line and off-line facility configurations.	4-9
Figure 4-7.	Example showing calculation of runoff treatment discharge for off-line treatment facilities—computed as 0.23cfs.	4-10
Figure 4-8.	Example showing calculation of runoff treatment discharge for on-line treatment facilities—computed as 0.28cfs.	4-11
Figure 4-9.	Extended precipitation timeseries regions.....	4-16
Figure 4-10.	Separation of on-site and off-site flows: Equivalent area option.	4-19
Figure 4-11.	Separation of on-site and off-site flows: Full area option.	4-20
Figure 4-12.	Separation of on-site and off-site flows: Bypass area option.	4-21
Figure 4-13.	Separation of on-site and off-site flows: Off-site area option.	4-22
Figure 4-14.	Engineering design steps for final design of infiltration facilities using the continuous hydrograph method (western Washington).....	4-55
Figure 4-15.	Engineering design steps for final design of infiltration facilities using the single hydrograph method (eastern Washington).....	4-56
Figure 4-16.	Engineering design steps for design of infiltration facilities: Simplified infiltration rate procedure.	4-64
Figure 4-17.	Infiltration rate as a function of the D_{10} size of the soil for ponds in western Washington.	4-66
Figure 4-18.	Determining infiltration rate of soil amendments.	4-68
Figure 4-19	CAVFS Detail.	4-69

Chapter 4. Hydrologic Analysis

4-1 Introduction

This chapter presents and defines the minimum computational standards for the types of hydrologic analyses required to design the various stormwater best management practices (BMPs) described in detail in Chapters 5 and 6. It also provides an explanation of the methods to be used for the modeling of stormwater facilities and the supporting data and assumptions that will be needed to complete the design. The computational standards, methods of analysis, and necessary supporting data and assumptions for designs in western Washington are different than those in eastern Washington. As a result, Section 4-3 includes design criteria and guidelines for western Washington, and Section 4-4 includes design criteria and guidelines for eastern Washington. The hydrologic analysis tools and methodologies presented in this chapter support the following tasks:

- Designing stormwater runoff treatment and flow control facilities
- Designing infiltration facilities
- Closed Depression Analyses
- Analyzing wetland hydroperiod effects

This manual makes numerous references to the *Hydraulics Manual*, where additional design guidelines can be found, including the minimum computational standards, methods of analysis, and necessary supporting data and assumptions for analysis and design of the following:

- General hydrology
- Culverts and other fish passage structures
- Open channel flow
- Storm sewer design
- Drainage from highway pavement (inlet spacing and curb and gutter)
- Hydraulics issues associated with bridge structure design
- Downstream analysis
- Pipe classification and materials

4-2 Project Considerations

Prior to conducting any detailed stormwater runoff calculations, the overall relationship between the proposed project site and the runoff it will create must be considered. This section provides guidelines regarding what parameters should be reviewed to adequately evaluate the project.

The general hydrologic characteristics of the project site dictate the amount of runoff that will occur and where stormwater facilities can be placed. Several sources of information will be useful in determining the information necessary for preliminary runoff analyses. Drainage patterns and contributing areas can be determined by consulting topographic contour maps generated from preliminary surveys of the area for the proposed project or by using contour maps from a previous project in the same area. For some projects, adequate information on soil characteristics can be found in soils surveys published by the Natural Resource Conservation Service (NRCS).

4-2.1 Estimating Stormwater Management Areas

Estimates of the area that will be required for stormwater management must be developed when the project layout is first being determined. These estimates of stormwater BMP sizes and areas may dictate changes to the roadway or other infrastructure design and support decisions to purchase additional right of way for the project. The following information is required to successfully estimate the approximate area required for stormwater treatment and flow control facilities:

- The basic requirements for the stormwater facility design
- The general hydrologic characteristics of the project site
- The basic footprint of the proposed roadway or other infrastructure improvement project

4-2.2 Local and State Requirements

In most cases, the basic requirements for stormwater facilities described in the *Highway Runoff Manual* (HRM) will be adequate to meet other state agency and local jurisdiction requirements. Section 1-1.5 explains to what extent a local jurisdiction's stormwater requirements apply to Washington State Department of Transportation (WSDOT) projects. The first part of any hydrologic analysis involves research to determine whether the project is located in an area where additional requirements prevail. This can typically be accomplished by consulting with region hydraulics or environmental staff. When stricter standards do apply, they are usually related to unique runoff treatment concerns: a need for flow control under more extreme storm conditions than is required by the HRM or a need for lower site discharge rates than are required by this manual. Either case is easily applied to the methods of analysis outlined in this chapter.

4-2.3 Soils

Quite often, additional sources of information are needed to adequately characterize on-site soils, particularly within existing highway rights of way and in other urban areas. The WSDOT Materials Lab can provide detailed information on soils and shallow groundwater characteristics in conjunction with geotechnical field data collection efforts. Typically, the Materials Lab must be informed of the need for gathering additional data for drainage analysis purposes early in the project design phase. This is very important for determining infiltration rates.

4-2.4 Determining Existing Conditions

Information on existing drainage facilities and conveyance system locations can be found in Hydraulic Reports from previous projects in the same vicinity or in as-built plans for the existing roadway. The local jurisdiction may have mapping and/or as-built information for storm drainage facilities near the WSDOT right of way and may know of other projects in the vicinity that documented drainage conditions. A site visit will help determine the basic hydrological characteristics of the proposed project site. Observations made during a field visit will serve to verify the information obtained through research and will show where that information may have been deficient. In nearly every instance, the information gained by visiting the site prior to designing the stormwater facilities will benefit the ensuing design effort.

4-2.5 Mapping Threshold Discharge Areas

The final part of determining the site's hydrologic characteristics is mapping the threshold discharge areas (TDAs). A TDA is defined as an on-site area draining to a single natural or constructed discharge location or multiple natural or constructed discharge locations that combine within $\frac{1}{4}$ mile downstream—as determined by the shortest flowpath. A TDA delineation begins at the first discharge location that exits WSDOT right of way and is based on preproject conditions. The purpose of this definition is to provide more flexibility in meeting the minimum requirements while still providing sufficient protection for the receiving water bodies. Note: All TDAs must be verified in the field.

To map a TDA, the designer must have an understanding of drainage basin delineation. A drainage basin includes all of the area that will contribute runoff to the point of interest. For example, in Figure 4-1, the designer must quantify off-site flow that discharges to the ditch, which is the point of interest. To determine the off-site area of land that contributes runoff to the ditch, topographic contours are needed. Where a contour forms a chevron (or the letter “V”) pointing in the direction of increasing elevation, that contour depicts a valley. Where the chevron points in the direction of decreasing elevation, that contour depicts a ridge. Ridges are the limits of a drainage basin, since precipitation falling on a ridge or peak will flow either to or away from the point of interest. Connecting the ridges and peaks on the contour map will form the boundary of the drainage basin.

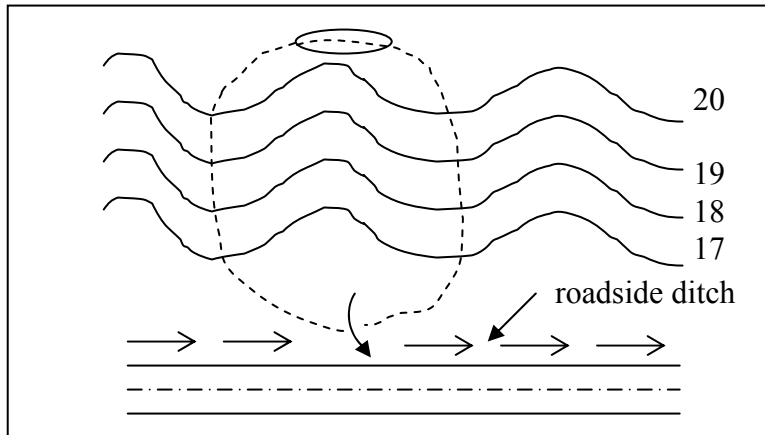

Figure 4-1. Drainage basin delineation example.

In pavement drainage, artificial ridges and peaks are formed by cross slopes and vertical curves. In Figures 4-2a, 4-2b, and 4-3, each drainage basin is delineated by the crown of the roadway to the top of the ditch backslope and between each vertical curve crest. If the discharges from both culverts join within $\frac{1}{4}$ mile downstream from the right of way, all four drainage basins would combine to make one TDA (as indicated in Figure 4-2a). If the discharges remain separate for at least $\frac{1}{4}$ mile downstream of the project site right of way, drainage basins A1 and A2 combine to make one TDA and drainage basins A3 and A4 combine to make a second TDA. Figure 4-2b and Step 3 below illustrate this situation, where the flow paths do not combine within $\frac{1}{4}$ mile and result in two separate TDAs. The new, replaced, and existing impervious areas must be estimated for each TDA. Minimum requirement thresholds are applied to each TDA. (See Chapter 3 for minimum requirement applicability.)

An example of how to determine whether the discharges join within $\frac{1}{4}$ mile is provided below with the use of Figures 4-2a and 4-2b.

Step 1

Measure $\frac{1}{4}$ mile along Flowpath A2.

Step 2

Measure $\frac{1}{4}$ mile along Flowpath A4. If the two flowpaths join within the shortest measured $\frac{1}{4}$ mile flowpath (Flowpath A2), the areas A1, A2, A3, and A4 are considered one TDA, as shown in Figure 4-2a.

An additional step is necessary if there is another flowpath in close proximity to the first discharge location, as shown in Figure 4-2b.

Step 3

Assuming areas A1, A2, A3, and A4 are within one TDA, measure $\frac{1}{4}$ mile along Flowpath A6. If Flowpath A2 (most upstream flowpath) and Flowpath A6 join within the shortest measured $\frac{1}{4}$ mile flowpath, all areas are considered one TDA. If the flowpaths do not

combine within the shortest measured ¼ mile flowpath, then the last discharge location is the beginning of a new TDA delineation and becomes the first discharge location for that downstream TDA. Figure 4-2b shows that Flowpath A2 and Flowpath A6 do not combine within the ¼ mile measured along the shortest flowpath, so areas A1, A2, A3, and A4 combine to form one TDA, while areas A5 and A6 combine to form a separate TDA.

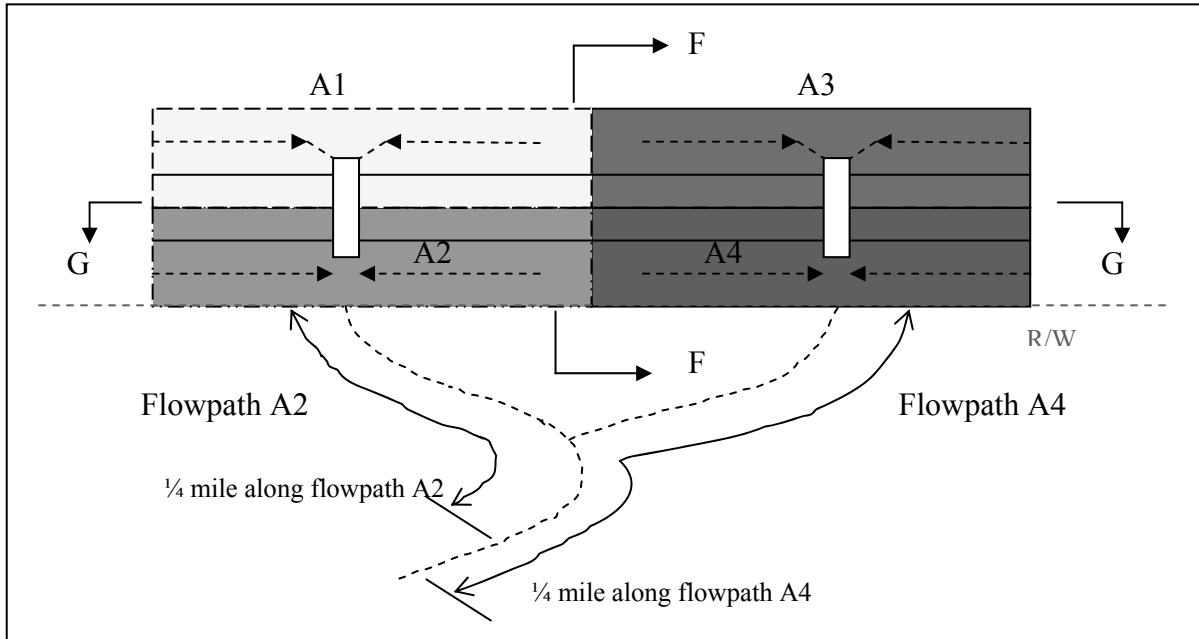

Figure 4-2a. Threshold discharge areas (plan – not to scale).

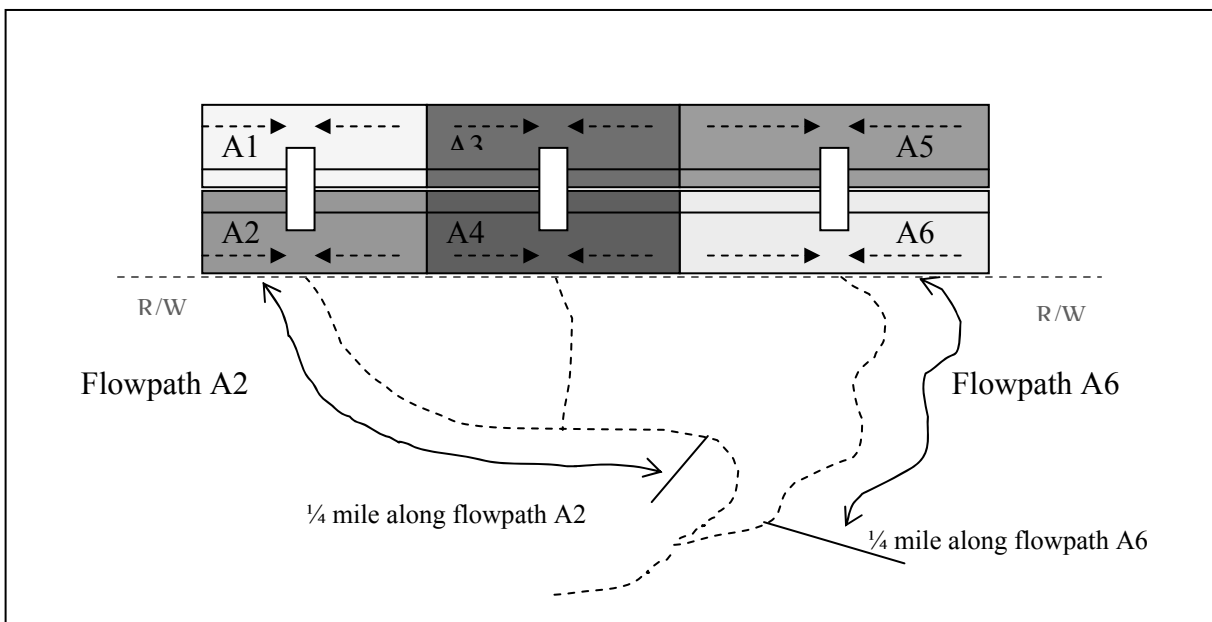

Figure 4-2b. Threshold discharge areas (plan – not to scale).

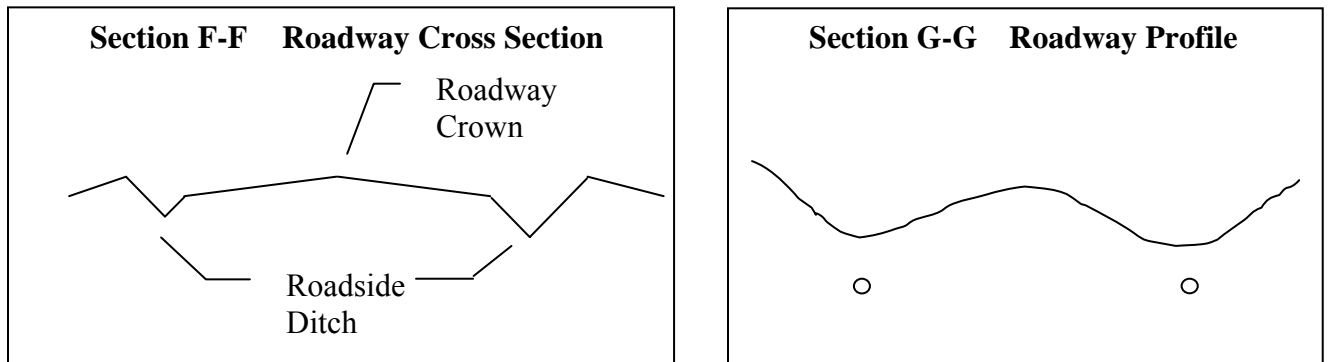

Figure 4-3. Threshold discharge areas (section and profile).

4-2.6 Conclusions

Once the basic stormwater requirements are understood and the general hydrologic characteristics of the site are known, the size of the area necessary for stormwater facilities can be estimated. This is done by examining the proposed project layout and determining the most suitable locations to place stormwater management facilities. With one or more such locations identified, the computation methods described later in this chapter can be applied using site data and an estimate of the required stormwater facility area(s) can be calculated. If this preliminary facility sizing is done early enough in the project design schedule, slight alterations can be made to the project alignment/footprint and adequate right of way can be purchased without causing undue cost or delay to the project. A final design of the stormwater facilities will have to be performed when the project layout is finalized.

The locations of new stormwater outfalls from WSDOT right of way should be provided to local agencies and added to WSDOT's outfall inventory to facilitate compliance with NPDES and Highway Runoff Rule requirements (WAC 173-270). For details on how to relay the outfall inventory information, contact a region hydraulics or water quality section representative.

Flow charts are presented in Figures 4-4 and 4-5 to help the designer navigate through the requirements of Chapter 4 and hydrologic analyses for typical projects.

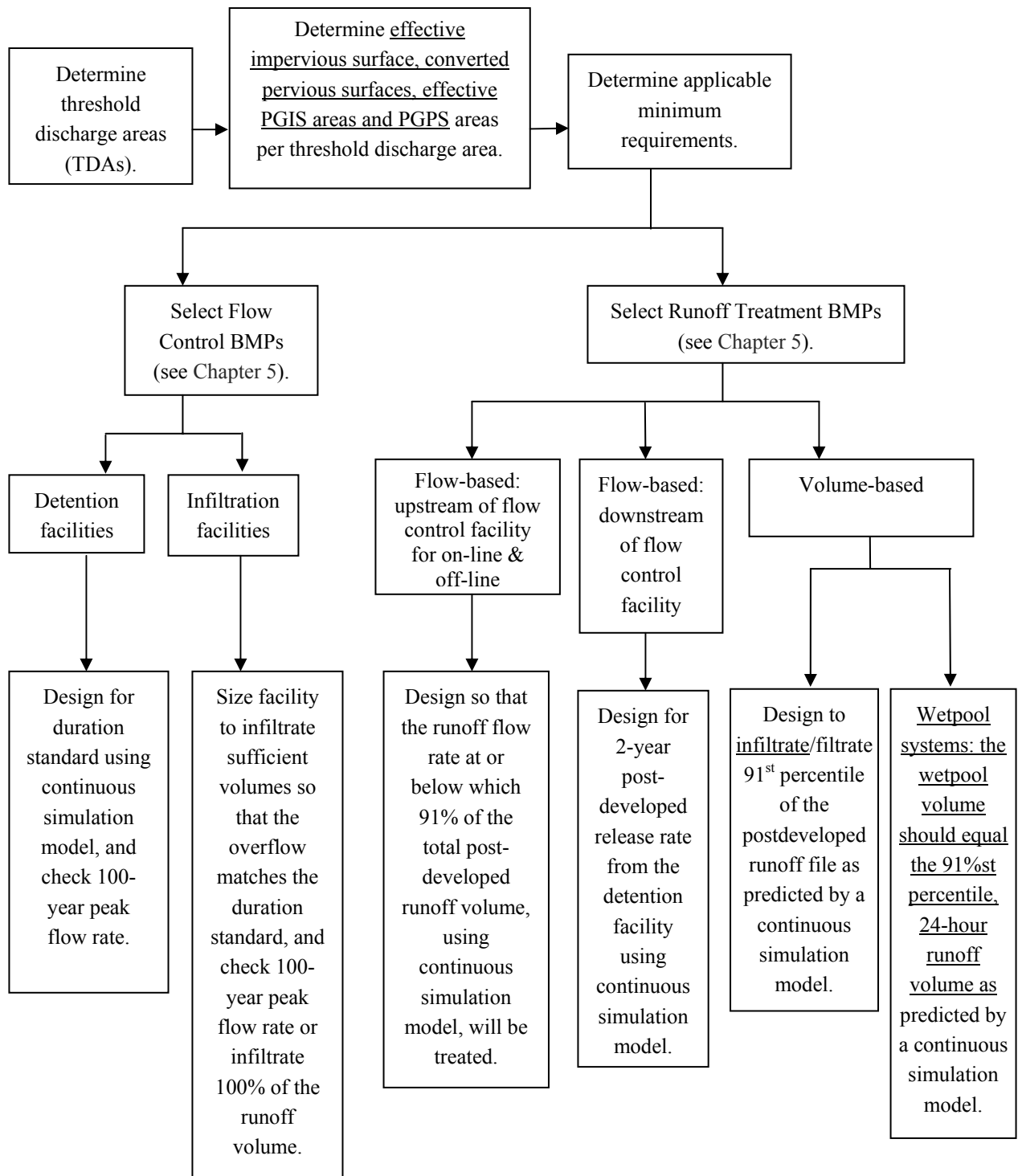

Figure 4-4. Hydrologic analysis flowchart for western Washington.

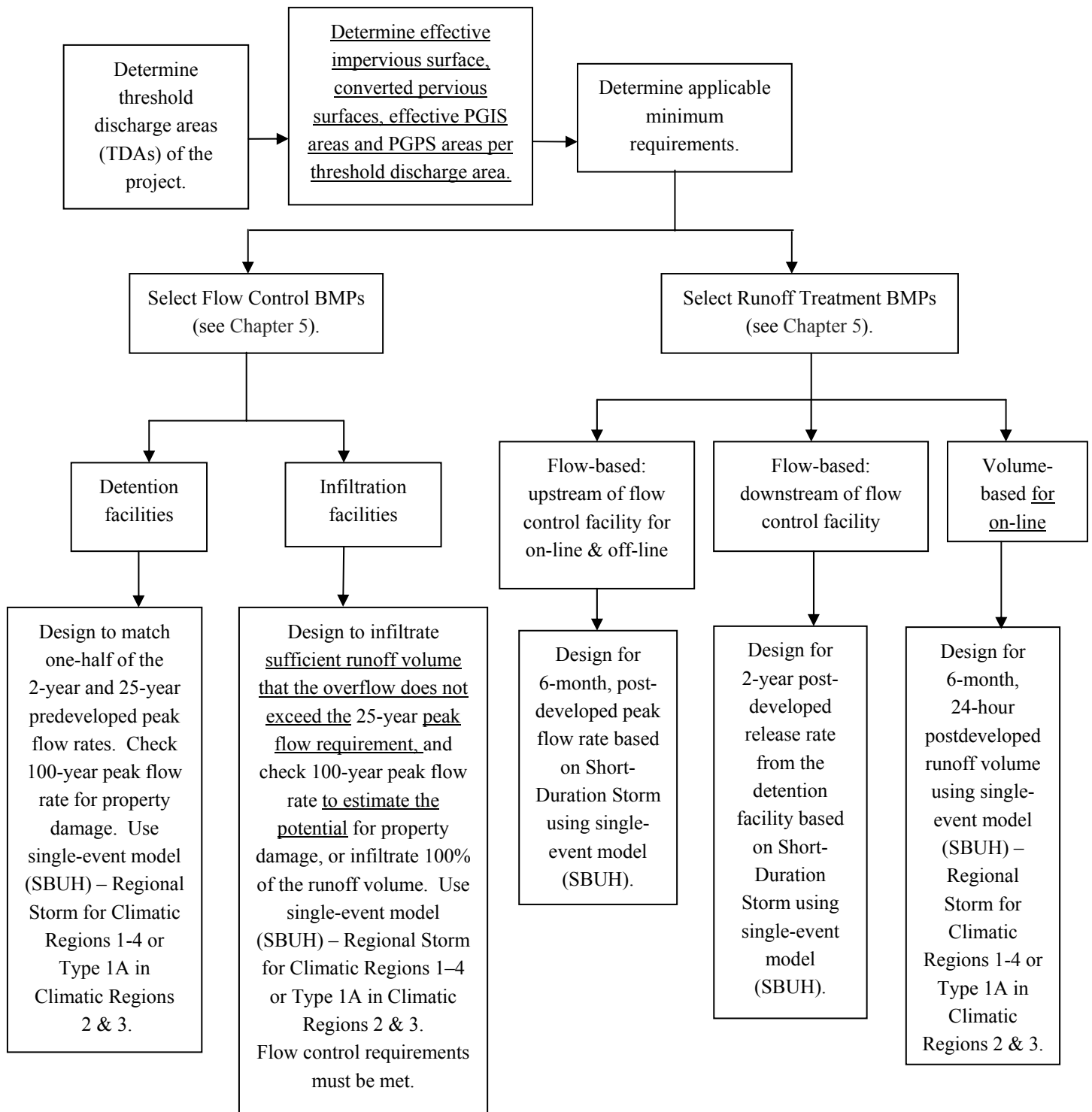

Figure 4-5. Hydrologic analysis flowchart for eastern Washington.

4-3 Western Washington Design Criteria

4-3.1 Runoff Treatment Flow-Based and Volume-Based BMPs

4-3.1.1 Flow-Based Runoff Treatment

An approved continuous simulation hydrologic model based on the U.S. Environmental Protection Agency's (U.S. EPA's) Hydrologic Simulation Program – Fortran (HSPF) is used when designing runoff treatment BMPs based on flow rate, in accordance with WSDOT Minimum Requirement 5 (see Section 3-3.5). WSDOT prefers that the program **MGSFlood** be used for designing flow-based runoff treatment BMPs in WSDOT right of way. The design flow rate for these types of facilities is dependent on whether the treatment facility is located upstream or downstream of a flow control facility and whether it is an *on-line* or *off-line* facility (see Figure 4-6).

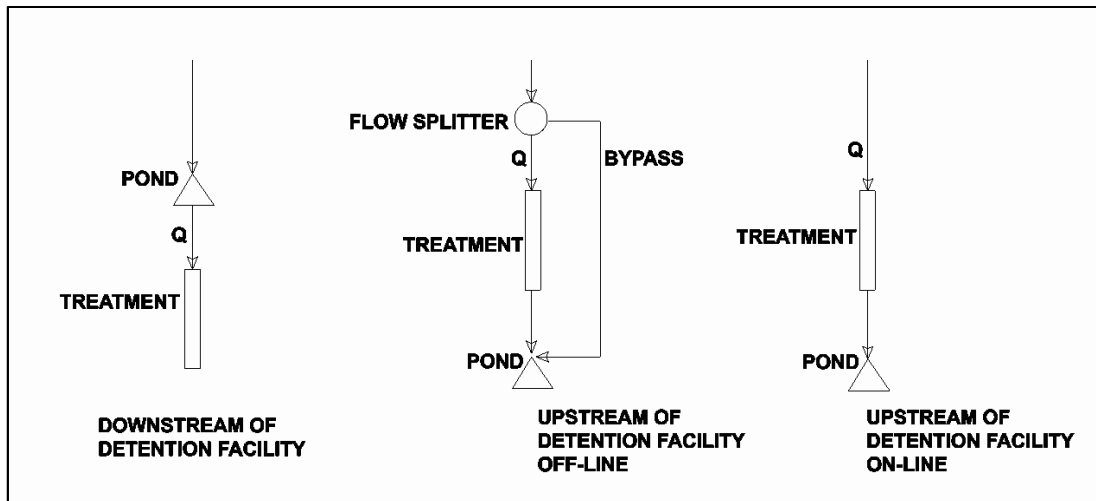

Figure 4-6. Typical on-line and off-line facility configurations.

Downstream of Flow Control Facilities

If the runoff treatment facility is located downstream of a stormwater flow control facility, the full 2-year recurrence interval release rate from the flow control facility, as estimated by an approved continuous simulation model, is used to design the treatment facility.

Upstream of Flow Control Facilities: Off-Line

The design flow rate for an off-line treatment facility located upstream of a flow control facility is the flow rate at or below which 91% of the runoff volume for the developed TDA will be treated, based on a 15-minute time step, as estimated by an approved continuous simulation model (see Figure 4-7). A high-flow bypass (flow splitter) is used to route the incremental flow in excess of the treatment design flow rate around the treatment facility.

(See Section 5-4.3, for more details on flow splitters.) It is assumed that flows from the bypass enter the conveyance system downstream of the treatment facility but upstream of the flow control facility. The bold horizontal line in Figure 4-7 is an example that shows the 91% runoff volume flow rate. All flows below that line will be treated, and the incremental portion of flow above that line will bypass the runoff treatment facility.

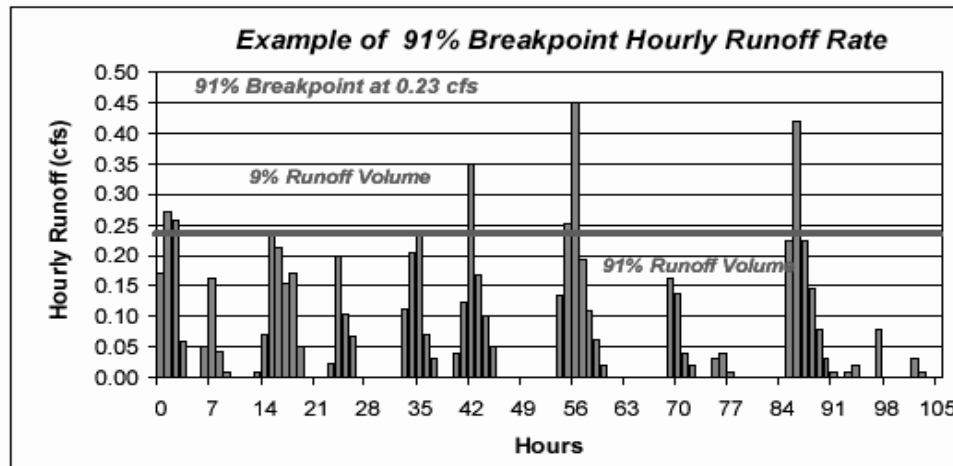

Figure 4-7. Example showing calculation of runoff treatment discharge for off-line treatment facilities—computed as 0.23cfs.

Upstream of Flow Control Facilities: On-Line

On-line runoff treatment facilities do not include a high-flow bypass for flows in excess of the runoff treatment design flow rate, and all runoff is routed through the facility. The design flow rate for these types of on-line treatment facilities is the flow rate at or below which 91% of the runoff volume occurs, based on a 15-minute time step, as estimated by an approved continuous simulation model, to be in compliance with Minimum Requirement 5 (see Section 3-3.5). MGSFlood will determine the hourly runoff treatment design flow rate as the rate corresponding to the runoff volume that is greater than or equal to 91% of the hourly runoff volume entering the treatment facility. The simulation model automatically generates 15-minute time step flows based on hourly flows. Because on-line treatment facilities receive greater volumes of inflow than off-line facilities, the design flow rate corresponding to the 91% breakpoint is higher than for off-line facilities. The higher design flow rate will result in a slightly larger treatment facility. Figure 4-8 indicates that the facility will receive all the flow, but will be sized for only 91% runoff volume flow rates, minus the red bars in its calculations for the developed TDA.

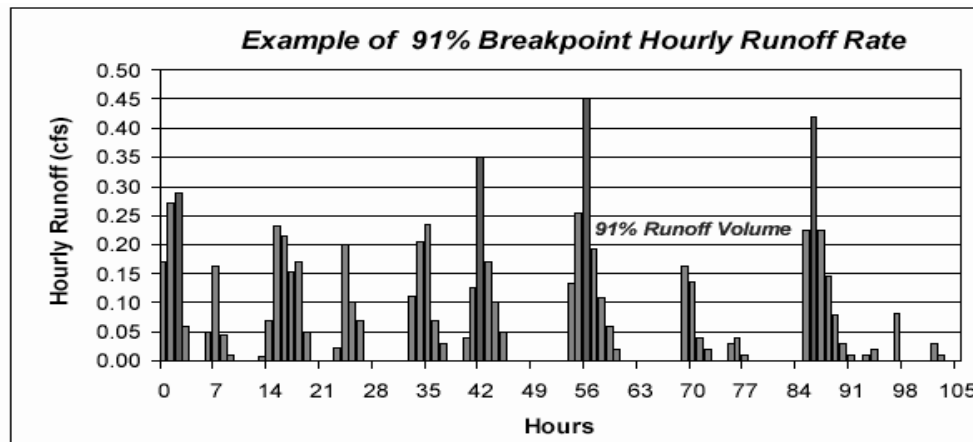

Figure 4-8. Example showing calculation of runoff treatment discharge for on-line treatment facilities—computed as 0.28cfs.

4-3.1.2 Volume-Based Runoff Treatment

For the purpose of designing runoff treatment BMPs based on volume (wetpool and infiltration treatment facilities), in accordance with Minimum Requirement 5 (see Section 3-3.5), the following methods can be used to derive the minimum required storage volume:

- Wetpool: An approved continuous simulation hydrologic model based on the U.S. EPA’s HSPF can be used. WSDOT prefers that the program MGSFlood be used. For wetpools, the required total wetpool volume is the 91st percentile, 24-hour runoff volume (no credit is given for infiltration losses) based on the long-term runoff record generated in the TDA of concern—as predicted based on a 1-hour time step.
- For other volume based systems such as infiltration and filtration BMPs, the minimum treatment needed is the storage volume that is necessary to achieve treatment of 91% of the influent runoff file as predicted using a continuous runoff model and a design infiltration/filtration rate.

If runoff from the new impervious surfaces and converted pervious surfaces is not separated from runoff from other surfaces on the project site and/or is combined with run-on from areas outside the right of way, volume-based runoff treatment facilities must be sized based on runoff from the entire drainage area. This is because runoff treatment effectiveness can be greatly reduced if inflows to the facility are greater than the design flows that the facility was designed to handle. For infiltration facilities, the 91st percentile, 24 hour runoff volume must be infiltrated within 36 hours. Under this premise, the storm/runoff ends 12 hours after the runoff period midpoint and combines with the 24-hour drain criteria. Therefore, the actual drawdown time is 36 hours. (See “Pond Design Using Routing Table” in Section 4-3.6.1, Continuous Simulation Method.)

For a summary of the flow rates and volumes needed for sizing runoff treatment facilities for various situations, see Table 3-3.

4-3.2 Flow Control Volume and Flow Duration-Based BMPs

An approved continuous simulation hydrologic model, based on HSPF, is used for designing flow control BMPs in accordance with Minimum Requirement 6 (see Section 3-3.6). WSDOT prefers that the program MGSFlood be used for designing flow control BMPs in WSDOT right of way. Stormwater discharges must match developed discharge durations to predeveloped durations for the range of predeveloped discharge rates from 50% of the 2-year peak flow up to the full 50-year peak flow. The 100-year peak flow must also be checked for flood control and prevention of property damage using the continuous simulation model.

Infiltration facilities for flow control must either infiltrate the entire runoff file, or provide sufficient infiltration so that the predicted overflows match the predeveloped durations for the range of predeveloped discharge rates from 50% of the 2-year peak flow up to the full 50-year peak. Table 3-6 summarizes the volumes needed for sizing flow control facilities for various situations.

4-3.3 Temporary Construction Site Erosion and Sediment Control

Interceptor dikes and swales, grass-lined channels, and pipe slope drains should be designed to be stable for the velocity generated by the 10-year, 15-minute flow rate predicted by MGSFlood. Sediment traps and temporary sediment ponds should be designed for the 2-year 15-minute flow rate predicted by MGSFlood for the developed site condition without flow control. The designer should consult the Headquarters Environmental Services Office or region hydraulics staff to determine if downstream conditions warrant that temporary erosion and sediment control (TESC) BMPs be designed to a higher level of protection beyond the 2-year, 15-minute event. The 10-year, 15-minute flow rate should be used if the project is expected to last several construction seasons. (See Appendix 6A for additional TESC BMP design criteria.) **Note: MGSFlood currently gives 1-hour flow rates. To convert from 1-hour to 15-minute flow rates, a correction factor of 1.3 (multiplied to 2-year, 1-hour flow rate) and 1.6 (multiplied to 10-year, 1-hour flow rate) must be applied.**

4-3.4 Exemptions for Flow Control

WSDOT has developed a standardized process to help the designer produce an acceptable hydraulic analysis for determining flow control exemptions. The process helps the designer determine how extensive an analysis needs to be for a particular project. (See Chapter 3 for a process that has been established for lakes and some river systems.) For further details on exemptions, flow dispersion, and flow control thresholds, see Minimum Requirement 6, Section 3-3.6.

4-3.5 Hydrologic Analysis Methods for Designing BMPs in Western Washington: HSPF versus SBUH

This section provides a brief description and in-depth discussion of the methodologies used for calculating stormwater runoff from a project site. It includes a discussion on estimating stormwater runoff with continuous simulation models versus single-event models such as Santa Barbara Urban Hydrograph (SBUH).

The Hydrologic Simulation Program – Fortran (HSPF) model is a U.S. EPA program for simulation of watershed hydrology and water quality for both conventional and toxic organic pollutants. The HSPF model uses information such as the time history of rainfall, temperature, and solar radiation, and land surface characteristics such as land use patterns and land management practices to simulate the hydrologic processes that occur in a watershed. The result of this simulation is a time history of the quantity and quality of runoff from an urban, forested, or agricultural watershed. Flow rate and sediment load, as well as nutrient and pesticide concentrations, can be predicted.

Unlike intensity-duration models, which are sensitive to the peak rainfall intensity, the SBUH method models runoff by analyzing a given time period of rainfall to generate a hydrograph sensitive to variations in the rainfall preceding and following the peak. It was specifically developed to model runoff from urbanized areas that have mostly impervious land usage.

4-3.5.1 Hydrologic Analysis for Runoff Treatment

A calibrated, approved continuous simulation hydrologic model based on HSPF is used when designing a flow rate-based runoff treatment BMP. This is because single-event models, such as SBUH, tend to underestimate the time of concentration, and the peak flow rate occurs too early. This affects treatment BMPs that are designed to achieve a specified flow residence time (the resulting designs are more conservative). Calculation of the flow residence time is sensitive to the shape of the inflow hydrograph. The inflow hydrograph is also of fundamental importance when designing an infiltration or filtration BMP, as these BMPs are sized based on a routing of the inflow hydrograph through the BMP.

When designing a volume-based runoff treatment BMP, a calibrated, approved continuous simulation hydrologic model based on HSPF such as MGSFlood or the Washington State Department of Ecology's (Ecology's) Western Washington Hydrology Model (WWHM) should be used.

4-3.5.2 Hydrologic Analysis for Flow Control

Because of single-event hydrologic model limitations, an approved continuous simulation model, rather than a single-event model such as SBUH, should be used to design flow control BMPs for WSDOT projects in western Washington. While SBUH may give acceptable estimates of total runoff volumes, it tends to overestimate peak flow rates from pervious areas, because it cannot adequately model subsurface flow (which is a dominant flow regime

for predevelopment conditions in western Washington basins). One reason SBUH overestimates the peak flow rate for a pervious area is that the actual time of concentration is typically greater than what is assumed. Better flow estimates could be made if a longer time of concentration was used. This would change both the peak flow rate (it would be lower) and the shape of the hydrograph (peak occurs somewhat later,) and the hydrograph would better reflect actual predeveloped conditions.

Another reason that SBUH overestimates the peak rates of runoff from undeveloped land is the curve numbers (CN) presented for single-event modeling in the 1995 *Highway Runoff Manual*. These curve numbers were developed by the U.S. Natural Resources Conservation Service (NRCS), formerly the Soil Conservation Service (SCS), and published as the Western Washington Supplemental Curve Numbers. These CN values are typically higher than the standard CN values published in NRCS Technical Release 55 (1986). In 1995, the NRCS recalled the use of the western Washington CNs for floodplain management and found that the standard CNs better describe the hydrologic conditions for rainfall events in western Washington. However, based on runoff comparisons with the King County Runoff Time Series (KCRTS), which is a continuous simulation model, better estimates of runoff are obtained when using the western Washington CNs for developed pervious areas such as parks, lawns, and other landscaped areas. Consequently, the CNs in this manual are changed to those in NRCS Technical Release 55, except for the open spaces category for the developed areas, which include lawns, parks, golf courses, cemeteries, and landscaped areas. For these areas, the western Washington CNs are used. Note: These changes are intended to provide better runoff estimates using the SBUH method. For CN values, see Appendix 4B.

When the SBUH is used to estimate runoff rates in a 24-hour storm event, it is not capable of simulating soil moisture characteristics that have a significant impact on generation of runoff. Sizing of stormwater BMPs based on 24-hour storms does not reflect the effects of longer-term storms in western Washington. The use of a longer-term (such as 3- or 7-day) storm is perhaps better suited for western Washington and could better capture the hydrologic effect of back-to-back storm events.

HSPF is a continuous simulation model capable of simulating a wider range of hydrologic responses than the single-event models like SBUH. For use in western Washington, WSDOT has developed the continuous simulation hydrologic model MGSFlood, based on HSPF. MGSFlood uses multiyear inputs of hourly precipitation and evaporation to compute a multiyear timeseries of runoff from the site. Use of precipitation input that is representative of the site under consideration is critical for the accurate computation of runoff and the design of stormwater facilities. Precipitation and evaporation timeseries have been assembled for most areas of western Washington and are stored in a database file accessed by the program.

Default HSPF model parameters that define rainfall interception, infiltration, and movement of moisture through the soil are based on work by the USGS and King County and have been included in MGSFlood. Pervious areas have been grouped into three land cover categories: forest, pasture, and lawn; and three soil/geologic categories: till, outwash, and

saturated/wetland soil—for a total of seven land cover/soil type combinations (as shown in Table 4-1). The combinations of soil type and land cover are called pervious land segments, or PERLNDS, in HSPF. Default runoff parameters for PERLNDS are loaded automatically by the program for each project and should not be changed. If the user changes these values, the changed values are noted in the project documentation report. If a basin or watershed has been calibrated, those PERLNDS values can be used, since they are site specific.

Table 4-1. Pervious land cover/soil type combinations used with HSPF model parameters.

Pervious Land Cover/Soil Type Combinations	
1.	Till/Forest
2.	Till/Pasture
3.	Till/Lawn
4.	Outwash/Forest
5.	Outwash/Pasture
6.	Outwash/Lawn
7.	Saturated Soil/All Cover Groups

4-3.6 Hydrologic Analysis Methods for Flow Control and Runoff Treatment Facility Design

This section presents a detailed discussion of the parameters necessary to design a stormwater flow control facility using an approved continuous simulation model.

4-3.6.1 Continuous Simulation Method

WSDOT's continuous simulation hydrologic model MGSFlood (see Section 4-3.5.2) uses the HSPF routines for computing runoff from rainfall on pervious and impervious land areas. Specifically, the program is intended to size stormwater detention and infiltration ponds, as well as calculate runoff treatment flow rates and volumes, to meet the requirements of Ecology's *Stormwater Management Manual for Western Washington* (SMMWW). It should not be used for conveyance design unless the conveyance system is downstream of a stormwater pond. (See Appendix 4A for a web link to a detailed example of this modeling approach and for information on how to obtain a copy of the public domain program.)

MGSFlood does not include routines for simulating the accumulation and melt of snow, and its use should be limited to lowland areas where snowmelt is typically not a major contributor to floods or to the annual runoff volume. In general, these conditions correspond to an elevation below approximately 1500 feet. MGSFlood can be used to model TDAs up to 320 acres (about one-half square mile). If a TDA falls outside the modeling guidelines above, contact region or HQ hydraulics staff for assistance.

Several factors must be considered in the design of a stormwater flow control facility. Based on the proposed project improvements, watershed and TDA can be determined and precipitation and runoff parameters can be applied to them. The continuous simulation model uses this information to simulate the hydrologic conditions at the site and estimate runoff. The flow control facility is then sized to detain the runoff in a way that closely mimics the runoff from the predeveloped site conditions. The designer must then verify that the flow control performance is in accordance with Minimum Requirement 6, (see Section 3-3.6). Key elements of continuous simulation modeling are presented below.

Precipitation Input

Two methods of transposing precipitation timeseries are available in the continuous simulation model: Extended Precipitation Timeseries Selection and Precipitation Station Selection.

Extended Precipitation Timeseries Selection

Extended Precipitation Timeseries uses a family of prescaled precipitation and evaporation timeseries. These timeseries were developed by combining and scaling precipitation records from widely separated stations, resulting in record lengths in excess of 100 years. Extended hourly precipitation and evaporation timeseries have been developed using this method for most of the lowland areas of western Washington where WSDOT projects are constructed. These timeseries should be used for stormwater facility design for project sites with a mean annual precipitation ranging from 24 to 60 inches and located in the region shown in Figure 4-9.

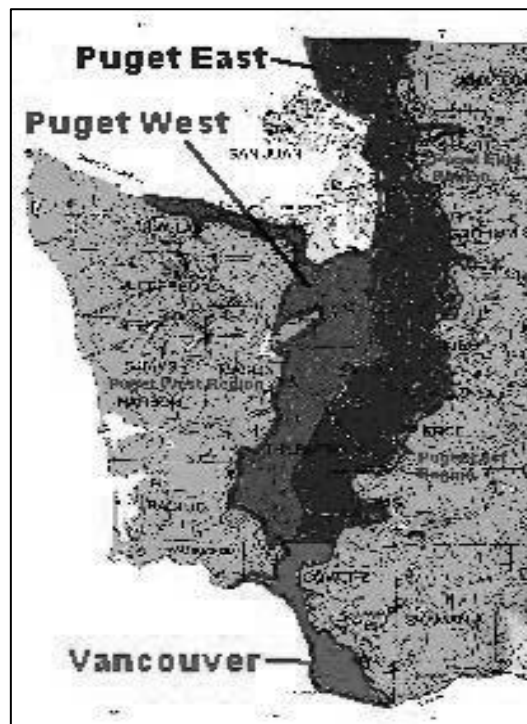

Figure 4-9. Extended precipitation timeseries regions.

Precipitation Station Selection

For project sites located outside the extended timeseries region, a second precipitation scaling method is used. A source gage is selected and a single scaling factor is applied to transpose the hourly record from the source gage to the site of interest (target site). The current approach for single factor scaling, as recommended in Ecology's SMMWW, is to compute the scaling factor as the ratio of the 25-year, 24-hour precipitation for the target and source sites. Contact region or Headquarters hydraulics staff if assistance is needed in selecting the appropriate gage. Updating areas with the extended precipitation timeseries will be done eventually for all of western Washington, based on available funding.

Watershed and Drainage TDA Characteristics

To facilitate rainfall-runoff modeling, project site drainage must be defined in terms of TDAs. Land cover and soil type can vary within a TDA; the continuous simulation model simulates the rainfall-runoff for each land cover/soil type combination separately. Nodes can be used to collect runoff from the tributary area for a given TDA and from the nodes of upstream TDAs. There is no attenuation of flow from TDA to TDA, as the hydrographs from the TDA are translated directly to the receiving node without hydraulic routing.

The hydroperiod of existing wetlands within a TDA should be evaluated to determine whether they are likely to be impacted by project runoff. This will make a difference when modeling for flow control. Please contact region or HQ hydraulics staff for additional guidance.

Predevelopment Land Cover

The first consideration when modeling project site runoff for flow control BMP sizing is the amount of pervious cover versus impervious surface in the overall basin. The hydrologic analysis for flow control to protect a receiving water is based on mitigating floods and erosion. The predeveloped land cover assumptions for modeling effective impervious surfaces for both eastern and western Washington can be found in Chapter 3, Minimum Requirement 6. Predeveloped condition information for stormwater retrofits can be found in Figure 3.4 and Section 3-4.

Reversion of Existing Impervious Surface Areas

Opportunities may emerge to remove an existing impervious surface due to roadway realignment, roadway abandonment, or other project condition rendering the existing impervious surface obsolete. Under these circumstances, reverting an impervious surface to a pervious surface may improve the hydrological functions of an area, thereby providing a proportional reduction in the amount of runoff generated. Note: At this time, when determining minimum requirement applicability, the concept of reversion of existing impervious surfaces only applies to flow control thresholds; it does not apply to runoff treatment thresholds.

The following *two-step approach* must be followed to analyze reversion of existing impervious surface areas in lieu of conventional surface water flow control. Only one of

these two steps can be applied, and they **cannot** be combined if a flow control facility is required.

Step 1

The first step involves evaluating the potential for stormwater impacts based on the concept and application of *net-new impervious surface*. Applying the net-new impervious surface concept requires removing existing impervious surface, incorporating soil amendments into the subsurface layers, and revegetating the area with evergreen trees—unless the predeveloped condition was prairie, which may be the case in some parts of eastern Washington. In this case, the net-new impervious surface concept is applied at the threshold discharge area (TDA) level when determining if triggers for flow control (see Minimum Requirement 6) have been exceeded, as specified in Section 3-3.6, and then only if the following criteria can be met:

- Existing impervious areas removed must be replaced with soils meeting the soil quality and depth requirements of the soil amendment criteria in Chapter 5.
- The new pervious area must be planted with native vegetation, including evergreen trees. For further guidelines, see the *Roadside Classification Plan* and the *Roadside Manual*.
- The new pervious area must be designated as a stormwater management area in the stormwater database (see Chapter 2), whether or not it receives runoff from adjacent areas.
- The new pervious area must be permanently protected from development. If the area is sited off state right of way, it must be protected with a conservation easement or some other legal covenant that allows it to remain in native vegetation.
- The outfall to which the new impervious surfaces—that are not provided with flow control as a result of being exempted by using a net approach—drain must be entered into the stormwater database (see Chapter 2) as a deficiency.

Step 2

If it is concluded that triggers for that particular TDA have been exceeded and any of the above criteria cannot be fully implemented (only low-lying native vegetation can be planted due to clear-zone restrictions), then application of the net-new impervious surface concept is not applicable and the reversion area must be evaluated strictly as a land use modification when modeling for flow control. In this case, if it is feasible and there is an opportunity within any TDA to rehabilitate an impervious area to a pervious area, it should be done, and techniques for flow control (as explained below in Modeling Best Management Practices) should be applied.

Separation of On-Site and Off-Site Flow

The following guidelines primarily apply to meeting flow control requirements and do not generally apply to meeting runoff treatment requirements unless otherwise noted.

On-site flows can be classified as mitigated and nonmitigated areas. For the purpose of discussing the requirement to separate on-site and off-site flows in this section, a *mitigated area* is that area representing the impervious surface that will receive flow control and/or runoff treatment. The *nonmitigated area* is that area representing the existing on-site impervious or pervious surface that will not receive flow control and/or runoff treatment. In general, runoff from on-site nonmitigated impervious and/or pervious surface areas greater than 50% of the mitigated area must bypass around the flow control facility. Three on-site options and one off-site option can be evaluated to deal with bypass systems.

1. **On-site, equivalent area option.** The *equivalent area* is an existing impervious surface area to which stormwater runoff treatment and/or flow control can be applied in place of providing treatment and/or flow control for an area of new impervious surface. *Equivalent* means equal in area, located within the same receiving water drainage basin (TDA), and having similar use characteristics (for example, similar ADT) to the impervious surface area being traded. The equivalent area should be upgradient of or in close proximity to the discharge from the new area. As exemplified in Figure 4-10, the flow control facility needs to be sized for 10 acres. Using the equivalent area option, runoff from existing impervious areas and new impervious areas would be routed to the facility so that 10 acres within the same TDA drains to the facility. This concept can also be applied to meeting the minimum requirement for runoff treatment. Note: Up to 5 acres of nonmitigated area is allowed to pass through the flow control facility. Figure 4-10 shows all nonmitigated area bypassing around the flow control facility.

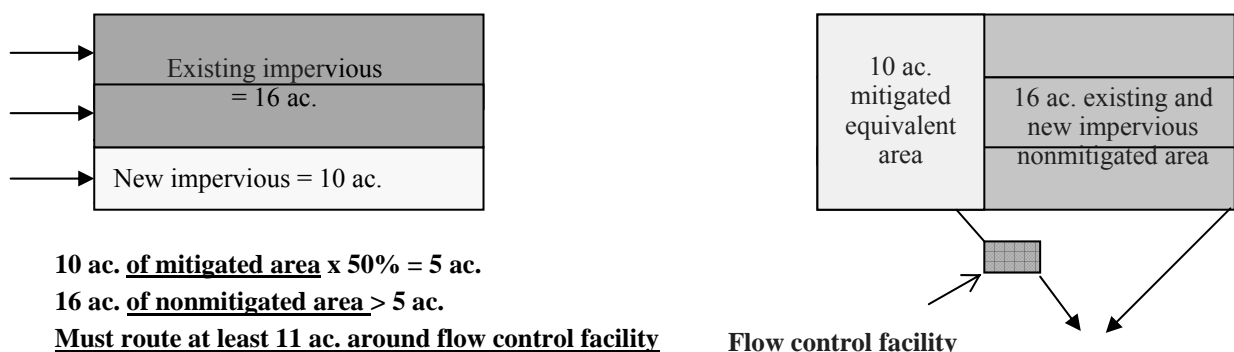

Figure 4-10. Separation of on-site and off-site flows: Equivalent area option.

2. **On-site, full area option.** The second option uses a detention pond with an orifice and riser release structure to represent the flow control facility for illustrative purposes. Other types of facilities can also be designed to meet flow control requirements for this scenario. Note: The 50% criteria for on-site nonmitigated area do not apply to this option.

The intent of this option is to size the detention facility for the mitigated area, but have both the mitigated and nonmitigated areas flow to the facility (see Figure 4-11). The detention facility and the outlet release structure initially should be sized using the drainage area for which flow control is required. A second modeling exercise is then conducted that routes flow from the mitigated area, plus any additional existing nonmitigated surface area—for which mitigation is not required—through the previously designed pond and outlet structure. Verify that the required criteria are still being met for the mitigated area and that the facility does not overflow.

If the flow can pass through the outlet structure without overtopping the pond (engaging the overflow structure), it is a successful design. If the pond does overtop, then the design is inadequate. There are two options the designer should consider for a successful design: (1) increase the distance between the design water surface elevation and the emergency overflow structure by raising the elevation of the emergency overflow structure and the pond embankment (note that a minimum of 1 foot of freeboard is required above the pond design water surface elevation), and (2) redesign the outlet structure. If option 2 is chosen, the most obvious change is to increase the diameter of the riser, while keeping the orifices the same, so that the higher flows can be discharged. However, the designer has to demonstrate that the new outlet structure design could meet the flow control duration requirement if the pond were only serving the mitigated area (the initial design condition). This option would provide flow control for all of the impervious surface draining to the stormwater facility, but the duration standards would be applied only to the mitigated area, even though there will be higher flows passing through the facility. This option does not meet a retrofit standard and is applicable for flow control facilities only. If the pond is also providing runoff treatment, the dead storage volume would be sized for the entire area flowing to the pond.

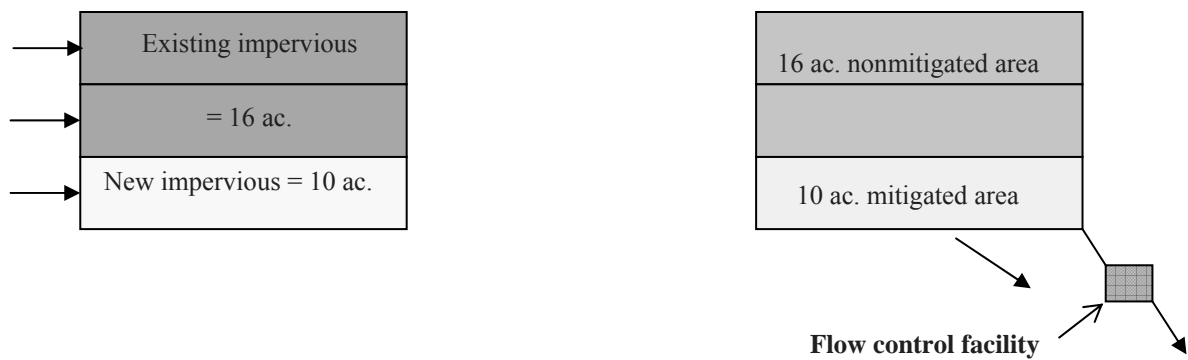

Figure 4-11. Separation of on-site and off-site flows: Full area option.

3. **On-site, bypass area option.** There may be instances when some of the area that must meet the flow control requirement cannot be separated from area that does not have to meet the requirement. The following bypass option, as depicted in Figure 4-12, provides a way to meet the overall intent of the flow control requirement for the total area that must be mitigated.
- Bypass: For this scenario, it is not possible to collect and convey a portion of the mitigated area to a stormwater facility. In this case, runoff from a portion of the area that must be mitigated may bypass the facility, provided **all** of the following conditions are met. These criteria apply only to that portion of the area that must be mitigated, but that is bypassed. (See Appendix 4A for a web link to an example that explains how a bypass area can be modeled using MGSFlood.)
 - Runoff from both the bypass area and the facility converges within $\frac{1}{4}$ mile downstream of the project site discharge point.
 - The facility is designed to compensate for the uncontrolled bypass area, so that the net effect at the point of compliance downstream is the same with or without bypass. Sometimes this is referred to as “overdetaining” the area that can be physically captured to make up for the area that could not be captured.
 - The 100-year developed peak flow rate from the bypass area will not exceed 0.4 cfs.
 - Runoff from the bypass area will not create a significant adverse impact to downstream drainage systems or properties.
 - Runoff treatment requirements applicable to the bypass area are met.

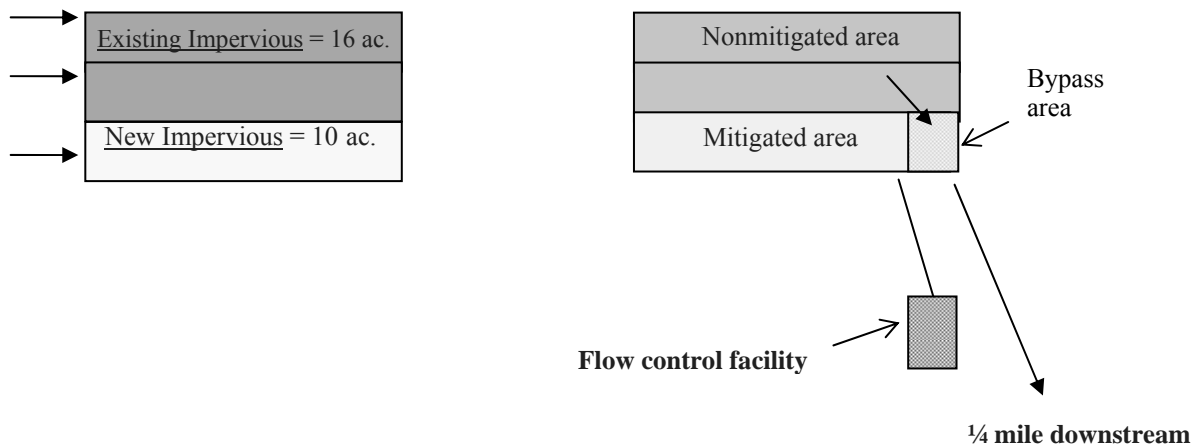

Figure 4-12. Separation of on-site and off-site flows: Bypass area option.

4. **Off-site, inflow area option.** Modeling guidelines are intended to avoid the mixing of off-site inflow with on-site runoff that flows through a flow control facility (see Figure 4-13). However, when it is not practicable to separate off-site and on-site flows, the following option will account for the additional off-site inflow in a way that meets the overall intent of mitigating the effects of increased runoff generated from the project site.
- Control of off-site inflow: With this option, flow control is provided for runoff from an upslope area outside the project limits, if the existing 100-year peak flow rate from the off-site inflow area is less than 50% of the 100-year peak flow rate of the on-site mitigated area—for post-developed conditions, without flow control—for the TDA. The control of off-site runoff must be designed to achieve the following:
 - Any existing contribution of flows to a wetland must be maintained.
 - Off-site flows that are naturally attenuated by the TDA under predeveloped conditions should remain attenuated, either by natural means or by implementing additional on-site flow control measures, so that peak flows do not increase.

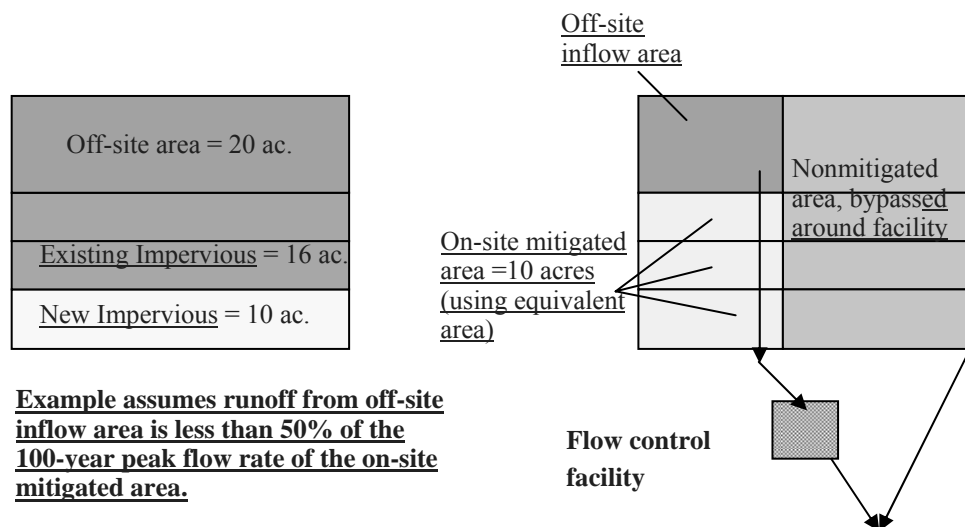

Figure 4-13. Separation of on-site and off-site flows: Off-site area option.

Existing ponds that were designed using the 1995 HRM method can now be modified to accept additional runoff from roadways that require widening. Please contact the HQ Hydraulics Office for current modeling guidance.

Hydrologic Soil Groups

For each TDA, land use is defined in units of acres for *predeveloped* and *developed* conditions. Soils at the project site must be classified into one of three default categories for use in the continuous simulation model: till, outwash, or saturated soil (as defined by the USGS). Mapping of soil types by the Soil Conservation Service (SCS), which is now the Natural Resource Conservation Service (NRCS), is the most common source of soil/geologic information used in hydrologic analyses for stormwater facility design. Each soil type defined by the NRCS has been classified into one of four hydrologic soil groups: A, B, C, and D. As is common in hydrologic modeling in western Washington, the soil groups used in the continuous simulation model generally correspond to the NRCS hydrologic soil groups shown in Table 4-2.

Table 4-2. Relationship between NRCS hydrologic soil group and HSPF soil group.

NRCS Group	HSPF Group
A	Outwash
B	Till or Outwash
C	Till
D	Wetland

NRCS Type B soils can be classified as either glacial till or outwash, depending on the type of soil under consideration. Type B soils underlain by glacial till or bedrock, or that have a seasonally high water table, are classified as till. Conversely, well-drained B-type soils should be classified as outwash. It is very important to work with the WSDOT Materials Lab or a licensed geotechnical engineer to make sure the soil properties and near-surface hydrogeology of the site are well understood, as they are significant factors in the final modeling results. Appendix 4B contains some soils classification information for preliminary work.

Wetland soils remain saturated throughout much of the year. The hydrologic response from wetlands is variable, depending on the underlying geology, the proximity of the wetland to the regional groundwater table, and the bathymetry of the wetland. Generally, wetlands provide some base flow to streams in the summer months and attenuate storm flows via temporary storage and slow release in the winter. Special design consideration must be taken into account when including wetlands in continuous simulation runoff modeling.

Modeling Best Management Practices (BMPs)

Flow control BMP design focuses on infiltrating, dispersing, and, as a last resort, detaining and discharging stormwater. In contrast to conventional BMPs that receive runoff at one location on the site, low-impact development (LID) BMP applications manage stormwater in small-scale, dispersed facilities located as close to the source of the runoff as possible. Due to the many different factors affecting both stormwater runoff treatment and flow control,

there is no one technique that will work in all situations. The following is a list of modeling strategies that must be considered when modeling BMPs:

1. **General modeling guidelines:** In determining the appropriate modeling approach, it is important to understand how stormwater infiltration, dispersion, and runoff occurred historically on the site. The site analysis (see Section 4-2) provides information on how the site and the surrounding areas currently process stormwater and how they processed stormwater before any land use changes had altered them. This information should aid the designer in determining the best site layout and deciding on appropriate BMPs that will either maintain or restore the natural predeveloped stormwater process. Use the following items from the site analysis to determine appropriate site layouts and BMPs:
 - Location and quantity of off-site drainage entering and on-site drainage leaving the site, if any
 - Slopes throughout the site
 - Locations of existing mature vegetation (trees and shrubs) that retain intact upper soil profiles for stormwater processing
 - Small depressions on-site that retain stormwater runoff
 - Depths and conditions of the upper soil profile (the A and B horizons), along with the identification of the lower soils
2. **Modeling and sizing in western Washington:** Modeling and sizing of multiple BMPs with a readily available continuous simulation model is possible with MGSFlood. In order to incorporate low impact development (LID) BMPs into the MGSFlood model, two tables have been created to spell out modeling techniques that can be assumed. Table 4-3 lists modeling techniques that can be assumed for site land uses in either outwash or till soils, where natural dispersion can be taken advantage of or where native vegetation can be reestablished by landscaping. Outwash soils would represent soils in Hydrologic Soil Group A and some uncompacted soils in Hydrologic Soil Group B. Till soils would represent some compacted soils in Hydrologic Soil Group B, as well as soils in Hydrologic Soil Groups C and D.

Table 4-3. Flow control modeling techniques based on land use.

BMP Type: Land Use	Assume the TDA is Composed of the Following:	
	Outwash Soil	Till Soil
Reversion of impervious surface ¹	100% Pasture	100% Grass
Landscaped with amended soils ²	25% Impervious, 75% Pasture, or Apply FC.02 Engineered Dispersion Criteria	50% Impervious, 50% Pasture, or Apply FC.02 Engineered Dispersion Criteria
Permeable pavement without perforated drain pipe ³	100% Grass	100% Grass
Permeable pavement with perforated drain pipe ³	100% Impervious	100% Impervious

¹ See Step 2 in preceding section titled “Reversion of Impervious Surface Areas” and Section 5-4.3.2, Soil Amendments.

² See Section 5-4.3.2, Soil Amendments.

³ See BMP IN.06, Permeable Pavement Surfaces, in Chapter 5.

Table 4-4 lists modeling technique procedures for specific LID systems in the form of modifications to model input parameters for pond and infiltration characteristics. Adjusting the pond and infiltration characteristics takes into account the water loss and avoids over-designing the flow control facility. MGSFlood has the routine for multiple structures BMP systems.

For sites with multiple types of BMPs, soil types, and/or land covers, modeling must incorporate multiple TDAs. Alternatively, a weighted average of the modeling techniques can be calculated for the combination of BMPs. The designer should note that these techniques are for flow control only, and must model the postproject conditions in order to determine the appropriate runoff treatment volume. Once this is complete, the designer can then apply these modeling techniques to land use to determine the appropriate flow control volume.

Table 4-4. Flow control modeling techniques for the interim.

BMP Type: Structural	Assume the Following Process for the Interim:	
	Outwash Soil	Till Soil
Drywells*	See Section 4-5.4.2.	See Section 4-5.4.2
Bioretention (Linear & Cell)*	Pond with a steady-state <u>saturated hydraulic conductivity</u> rate.	Pond with a steady-state <u>saturated hydraulic conductivity</u> rate.
Compost-Amended Soils*	Apply BMP FC.02, Engineered Dispersion Criteria, or Model as Pasture.	See Section 4-5.3.3.

* These BMPs can be modeled using MGSFlood. Please contact the Region Hydraulics Office first to obtain procedures, or see the web link: www.wsdot.wa.gov/Design/Hydraulics/Training.htm

Runoff Timeseries Generation

Precipitation and evaporation for the selected climate region are used in the continuous simulation model, and runoff is computed for predevelopment and postdevelopment conditions. The continuous simulation model stores this information as a runoff timeseries. The computed runoff timeseries' are not saved for each project when using MGSFlood; thus the runoff must be recomputed before performing any BMP design iterations to ensure the direct access file is up to date and contains runoff for the project currently under consideration.

Runoff computations are performed on a *water year* basis; that is, they begin on October 1 and end on September 30. This is because the soils are typically driest at the beginning of fall and a single set of antecedent conditions can be used for all regions of western Washington. A time period shorter than the full record can be used for runoff computations; however, the full period of record should be used in facility design to provide the most accurate flow computations.

Flow Control Facility Design

Flow control facility design can be completed in one of two ways: by defining the pond hydraulics in the *Pond Hydraulics Excel Spreadsheet* (www.wsdot.wa.gov/Design/Hydraulics/ProgramDownloads.htm) or by using an optimization routine available in a proprietary version of MGSFlood.

The flow control analysis for detention pond design should include the detention pond surface area as impervious surface. Regardless of the method used for sizing a flow control facility, detention pond design must take into account the effect that the actual pond will have as a land use change in the postdeveloped condition. Therefore, the flow control analysis should also include the pond surface area in the postdeveloped condition as an impervious surface since the precipitation falling on the detention pond surface will result in a runoff volume that will contribute directly to the flow control facility. In the predeveloped condition, the detention pond top surface area should be represented by its existing land cover condition. This will require at least two iterations using MGSFlood to properly size the facility. The water quality flow rates determined from this analysis should be used to size runoff treatment BMPs that are downstream of the flow control facility. A separate model without the pond area should be used for sizing runoff treatment BMPs that are upstream of the flow control facility, since the runoff volume from this pond area will not contribute to the runoff treatment BMP.

Pond Design Using Routing Table

Routing is performed using the information entered in the *Pond Hydraulics Excel Spreadsheet*. Information can be keyed into and copied from the spreadsheet and pasted into the hydrology program (MGSFlood or WHAM) using the Windows clipboard function. *Elevation* is the water surface elevation in the pond; *Area* is the pond surface area (acres); *Volume* is the pond volume (acre-feet); *Discharge* is the pond discharge (cfs); and *Infiltration* is the

infiltration rate (cfs) through the pond bottom. Water infiltrated through the pond bottom does not contribute to the computed pond outflow. (See Appendix 4A for a web link to example problems that will provide suggestions for manipulating the design to achieve matching predeveloped and postdeveloped durations.)

Pond Design Using Optimization

The proprietary version of MGSFlood includes routines for computing pond hydraulics and automatically sizing detention pond and outlet works to meet the duration-based flow control standard (see Table 3-6). Designing stormwater ponds to this standard is a laborious, iterative process, whereby the runoff timeseries (typically 40 years or more) is routed through the pond, and flow-duration statistics are computed and compared with predeveloped flow-duration statistics. The automatic pond-sizing routine in MGSFlood performs this pond design procedure.

The automatic pond-sizing optimization routine in the MGSFlood Hydraulic Structures add-in module will determine the pond size and outlet configuration for three pond types: (1) a detention pond with no infiltration, (2) a detention pond with minor infiltration, and (3) an infiltration pond. The characteristics of these pond types are listed in Table 4-5.

MGSFlood also has the following features:

1. Option for simulating multiple structures to allow the designer to account for infiltration that occurs upstream of a detention facility and to analyze sites with multiple treatment facilities.
2. Determines whether the runoff treatment volumes can be infiltrated in 36 hours. Under this premise, the storm/runoff ends 12 hours after the runoff period midpoint and combines with the 24-hour drain criteria; therefore, it would take 36 hours to drain the pond.
3. Subroutine that provides water surface elevation magnitude-frequency statistics and reports these in the project report.
4. Subroutine that computes varying infiltration rates as a function of pond depth using the Detailed Approach Method (Massmann's) equations.
5. Subroutine to compute the volume of stormwater treated by a sand filter.
6. Subroutine that states the percentage of runoff that infiltrates through the pond bottom relative to the total pond inflow.
7. Predevelopment, 100-year line on pond performance flow duration graph.
8. Subroutine for infiltration trench design on the embankment or in the ditch line.
9. Subroutines for compost-amended vegetated filter strips (CAVFS), filter strips, and flow splitters.

Table 4-5. Characteristics of detention and infiltration ponds sized using MGSFlood optimization routine.

Characteristic	Detention Pond	Infiltration Pond
Pond Configuration	Riser Structure With Low-Level Circular Orifice and Vertical Rectangular Upper Orifice	Overflow Riser Only
Valid Infiltration Rates	0.00–0.10 inches/hour	0.05–50 inches/hour
Optimization Levels	Quick or Full	Quick Only

Two levels of optimization are available for detention pond sizing: Quick Optimization and Full Optimization. Quick Optimization determines a “ballpark” solution in a relatively short time (usually less than one minute). Full Optimization does an exhaustive search of potential solutions, seeking a configuration for the minimum pond size required to meet the flow duration standard. The Full Optimization routine usually converges on a solution in less than ten minutes, depending on the speed and memory of the computer.

The pond-sizing optimization routine uses general input about the pond geometry, including:

- Pond length-to-width ratio
- Pond side slope
- Pond floor elevation
- Riser crest elevation
- Pond infiltration rate

The pond-sizing routine uses this information to establish the geometric relationships for the pond configuration. The program establishes a parameter space of possible solutions by varying the pond bottom area and the sizes and elevations of hydraulic devices for the outlet structure. The program then routes the developed runoff timeseries through the pond and seeks to find a solution that provides the minimum pond size to meet the discharge flow duration requirements.

Once the optimization has determined a pond size, it is still possible to go back to the first tab under Pond/Vault Geometry and manually manipulate the pond size under the Prismatic Pond Geometry or the Elevation Volume Table for irregularly shaped ponds.

The standard outlet configuration used for detention ponds consists of a circular low-level orifice and a vertical rectangular orifice (slot). If a different outlet configuration is desired, the volume-discharge characteristics of the desired configuration can be set to match the volume-discharge characteristics returned by the program for the orifice/slot weir configuration. The low-level circular orifice is assumed to be free of tailwater effects. If tailwater conditions are present, first use the optimization routine to determine the pond configuration without consideration of tailwater. Then, include the tailwater rating table and manually adjust the pond configuration to meet the flow duration design criteria.

There is a wide variety of combinations of hydraulic devices, device sizes and invert heights, and pond configurations that can be used to match the flow duration standard. However, it is difficult to find a pond configuration that minimizes the pond volume and meets the duration standard using a manual trial and error approach. The automatic pond-sizing routine searches the parameter space of possible solutions and seeks to find the minimum pond size to meet the flow duration standard.

In some situations, usually when there are “outliers” in the precipitation data or precipitation data of poor quality are used, the pond design may not meet all design criteria. In these cases, the pond design determined by the MGSFlood program is returned to the Hydraulic Structures and Pond/Vault Geometry tabs for manual refinement. The user can make modifications to the design, and flows can be routed through the pond using manual mode.

Flow Frequency and Duration Statistics Check

To analyze a stormwater pond’s effectiveness at reducing postdevelopment flows to predeveloped levels, flows are first routed through the pond. Statistics can be computed and graphs created to show the performance graphically. Pond performance can be assessed by comparing the flow frequency and duration statistics for the pond outflow with the statistics computed for the predeveloped condition. The designer must also check the 100-year peak flow for flood control and property damage. The designer should review the history file and verify that the postdeveloped 100-year peak is less than the predeveloped 100-year peak flow. If the postdeveloped peak flow is not less than the predeveloped 100-year peak flow, the designer should field verify that property damage will be prevented.

4-4 Eastern Washington Design Criteria

This section provides a discussion of the methodologies used for calculating stormwater runoff from project sites in eastern Washington. It includes a discussion on estimating stormwater runoff with single-event models, such as the Soil Conservation Service (SCS) unit hydrograph method and more information on the eastern Washington design storm events (see Appendix 4C).

The suggested hydrologic analysis method for most WSDOT project sites in eastern Washington is either the SCS or SBUH method. The input required for a single-event hydrograph method includes pervious and impervious TDAs; times of concentration; pervious and impervious curve numbers; design storm precipitation; and a design storm hyetograph. An approved single-event model, such as StormShed, should be used for calculating runoff characteristics. Single-event models are explained in more detail in Section 4-4.6. Runoff curve numbers and the precipitation data differ considerably in eastern and western Washington (see Appendix 4B).

Note: The threshold discharge area concept must also be applied to projects in eastern Washington (see Section 4-2.5).

After the existing and postdeveloped hydrographs are computed for the project site, the results are routed through a level pool reservoir. The level pool reservoir is a model of either a detention or an infiltration facility. If a detention facility is proposed, the design includes a flow control structure consisting of one or more orifices in a riser or baffle wall that slowly releases the outflows. If an infiltration facility is proposed, the model input includes the infiltration pond/trench area, design infiltration rate, and outlet control facility parameters—if only a portion of the design storm hydrographs will infiltrate and some flow will be released to a surface conveyance system. The level pool routing method is used to optimize the size of the facility with the space and depth available and meet the design criteria from Minimum Requirement 6 (see Section 3-3.6).

4-4.1 Runoff Treatment Flow-Based and Volume-Based BMPs

Runoff treatment BMPs are used to treat the stormwater runoff from pollutant-generating surfaces and should be designed in accordance with Minimum Requirement 5 (see Section 3-3.5). Some treatment BMPs are sized based on flow rate, while others are sized based on volume of runoff. For example, a bioswale or proprietary filtration BMP is sized based on flow rate, whereas an infiltration pond is sized based on runoff volume. Sizing is dependent on flow rates or volumes, as detailed in the following sections. The criteria for sizing runoff treatment facilities in eastern Washington are summarized in Table 3-4.

4-4.1.1 Flow-Based Runoff Treatment

The design flow rate for these types of facilities is dependent on whether the treatment facility is located upstream of a flow control facility and whether it is an *on-line* or *off-line* facility (see Section 4-3.1.1 for examples). Most treatment facilities can be designed as on-line systems, with flows greater than the runoff treatment design flow rate simply passing through the facility as overflow, with lesser or no pollutant removal. However, it is sometimes desirable to restrict flows to treatment facilities and bypass the remaining higher flows around them. These are called off-line systems.

4-4.1.2 Volume-Based Runoff Treatment

Runoff treatment facilities are designed based on volumes and must be sized for the entire flow volume that is directed to them. The following method can be used to derive the storage volume.

- **Wetpool and Infiltration:** The NRCS curve number equations (see Section 4-4.6.2) can be used to determine the runoff treatment design storm runoff volume. This is the volume of runoff from the storm noted in Table 3-4. WSDOT prefers that StormShed, an SBUH-based program, be used for this method to size volume-based runoff treatment BMPs. The size of the wetpool or infiltration storage volume is the same whether it is located upstream or downstream of a flow control facility or coupled with the flow control facility.

If the runoff from the new impervious surfaces and converted pervious surfaces is not separated from runoff from other surfaces on the project site, and/or is combined with run-on from areas outside the right of way, the runoff treatment facilities must be sized for the entire flow volume that is directed to them. Infiltration facilities must infiltrate 6-month, 24-hour total runoff volume within 72 hours after precipitation has ended.

4-4.2 Flow Control BMPs

An approved single-event model must be used when designing flow control BMPs, in accordance with Minimum Requirement 6 (see Section 3-3.6). WSDOT prefers that StormShed be used for designing flow control BMPs in WSDOT right of way. Stormwater discharges must match developed peak flows to predeveloped peak flows for the range of predeveloped discharge rates noted in Table 3-7.

4-4.3 Temporary Construction Site Erosion and Sediment Control

Interceptor dikes and swales, grass-lined channels, pipe slope drains, sediment traps, and temporary sediment ponds should be designed for peak flows or volumes from the 6-month, 3-hour storm using a single-event model. The designer should consult the HQ Environmental Services Office (ESO) or region hydraulics staff to determine whether a higher level of protection is needed beyond the 6-month, 3-hour storm due to the time of year for construction (freezing conditions and snowmelt); the downstream conditions; or the project is expected to last several construction seasons. (See Appendix 6A for additional TESC BMP design criteria.)

4-4.4 Exemptions for Flow Control

WSDOT has developed a standardized process to aid the designer in producing an acceptable hydraulic analysis for determining flow control exemptions. The process will help the designer determine how extensive an analysis must be for a particular project. (See Chapter 3 for a process that has been established for lakes and some river systems.) Please refer to Minimum Requirement 6 (see Section 3-3.6) for further details on exemptions, flow dispersion, and flow control thresholds.

4-4.5 Hydrologic Analysis Methods for Flow Control and Runoff Treatment Facility Design

This section presents the general process involved in conducting a hydrologic analysis using single-event hydrograph methods to (1) design retention/detention flow control facilities and (2) determine runoff treatment volumes. The exact step-by-step method for entering data into a computer model varies with the different models and is not described here (see the Documentation or Help modules of the computer program). Predeveloped and

postdeveloped site runoff conditions must be determined and documented in the Hydraulic Report.

The process for designing retention/detention flow control facilities in eastern Washington is presented below. Review Minimum Requirement 6 (see Section 3-3.6) to determine all the requirements that will apply to the proposed project.

1. Determine rainfall depths for the site (see Appendix 4A).
 - 2-year – 24-hour
 - 25-year – 24-hour
 - 100-year – 24-hour
2. Determine predeveloped soils type and hydrologic group (A, B, C, or D) from SCS maps (see Section 4-4.6.2).
3. Determine predeveloped and postdeveloped TDAs and the subsequent pervious and impervious area (in acres) for each condition (see Section 4-2.5 for more details).
4. Determine curve numbers for pervious and impervious area using hydrologic soil groups for both the predeveloped and postdeveloped conditions (see [Section 3-3.6.4](#), Appendix 4B, and Equations 4-10 and 4-11).
5. Determine predeveloped and postdeveloped time of concentration. StormShed will do this calculation if the designer enters length, slope, roughness, and flow type (see Section 4-4.6.2).
6. Select storm hyetograph and analysis time interval. Check that the analysis time interval is appropriate for use with storm hyetograph time increment (see [Appendix 4C](#)).
7. For each TDA, input the data obtained above into the computer model for each predeveloped and postdeveloped storm event.
8. Have the computer model compute the hydrographs.
9. Review the peak flow rate for the predeveloped conditions in the 2-year and 25-year storm events. The allowable release rate is listed in Table 3-7. Note: In some cases, the predeveloped 2-year peak flow rate may be 0 cfs, which means there is no discharge from the site. The 2-year postdeveloped flows in this situation must be retained as dead storage that will ultimately infiltrate or evaporate.
10. Review the peak flow rate for postdeveloped conditions in the 2-year and 25-year storms. Compare the increases in peak flow rates for 2-year and 25-year design storms to determine whether the project qualifies for an exemption.

11. Assume the size of the detention facility and input the data into the computer model. Refer to the volume of the design storm hydrograph computed in Step 8 for a good assumption of the detention volume required.
12. Assume the size of the orifice structure and input the data into the computer model. A single orifice at the bottom of the riser may suffice in some cases. In other projects, multiple orifices may result in decreased pond sizes. A good approximation would be to assume a 1-inch-diameter orifice per 0.05 cfs outflow for a typical pond.
13. Use the computer model to route the postdeveloped hydrographs through the detention facility and orifice structure. Compare the postdeveloped peak outflow rates to allowable release rates from Step 9.
14. If the postdeveloped peak outflow rates exceed the allowable release rates, adjust detention volume, orifice size, orifice height, or number of orifices. Keep running the computer model and adjusting the parameters until the postdeveloped outflow rates are less than or equal to the allowable release rates.
15. The flow control analysis for detention pond design should include the detention pond surface area as impervious surface. The detention pond design must take into account the effect that the actual pond will have as a land use change in the postdeveloped condition. Therefore, the flow control analysis should also include the pond surface area in the postdeveloped condition as an impervious surface since the precipitation falling on the detention pond surface will result in a runoff volume that will contribute directly to the flow control facility. In the predeveloped condition, the pond top surface area should be represented by its existing land cover condition. This will require at least two iterations using StormShed to properly size the detention facility. The water quality flow rates determined from this analysis should be used to size runoff treatment BMPs that are downstream of the flow control facility. A separate model without the pond area should be used for sizing runoff treatment BMPs that are upstream of the flow control facility since the runoff volume from this pond area will not contribute to the runoff treatment BMP.
16. Check the 100-year release rate and compare to predeveloped conditions, and check for potential property damage.
17. Calculations are complete.

Examples can be found through the web links, which are provided in Appendix 4A.

The following is the process for calculating runoff treatment design volumes or flow rates. Note that the data for many of the initial steps matches the data used in designing retention/detention flow control facilities described above.

1. Review Minimum Requirement 5 (see Section 3-3.5) to determine all requirements that will apply to the proposed project.
2. Determine the climatic region and Mean Annual Precipitation (MAP) (see Appendix 4A).
3. Determine the rainfall for the site depending on the treatment BMP (see Appendix 4A and Section 4-4.1).
4. Multiply the rainfall by the appropriate coefficient to determine the 6-month precipitation (see Appendix 4C).
5. Determine the existing soils type and hydrologic group (A, B, C, or D) from SCS maps (see Section 4-4.6.2).
6. Determine postdeveloped TDAs and the subsequent pervious and impervious area (in acres) requiring treatment that contributes flow to the treatment BMP (see Section 4-4.6.2).
7. Determine curve numbers for pervious and impervious area using the hydrologic soil group for the postdeveloped condition (see Appendix 4B).
8. Determine postdeveloped time of concentration; StormShed computes this when the designer inputs length, slope, roughness, and flow type (see Section 4-4.6.2).
9. If modeling the short-duration storm hyetographs, select the short-duration rainfall type in StormShed. Determine that the analysis time interval is appropriate for use with the storm hyetograph time increment (see Appendix 4C).
10. Input data obtained from above into StormShed for the postdeveloped storm event.
11. Have the model compute the hydrograph.
12. For the design of flow-based treatment BMPs, the computed peak flow from the 6-month, 3-hour hydrograph is the design flow.
13. For the design of volume-based treatment BMPs, the computed volume from the 6-month, 24-hour storm is the design volume.

Examples can be found through the web links, which are provided in Appendix 4A.

4-4.6 Single-Event Hydrograph Method

In eastern Washington, a single-event hydrograph method is typically used for calculation of runoff, with an integrated set of hydrology design tools developed to address the needs of conventional engineering practice. There are many single-event models based on the SCS (Soil Conservation Service) and SBUH methodologies that include level pool routing, pipe

and ditch conveyance system analysis, and backwater computation. Appendix 4A provides a link to the approved WSDOT single-event model.

An SBUH analysis requires that the designer understand certain characteristics of the project site, such as drainage patterns, predicted rainfall, soil type, area to be covered with impervious surfaces, method of drainage conveyance, and the flow control BMP that will be used. The physical characteristics of the site and the design storm determine the magnitude, volume, and duration of the runoff hydrograph. Other factors, such as the conveyance characteristics of channel or pipe, merging tributary flows, and type of BMP used, will alter the shape and magnitude of the hydrograph. The key elements of a single-event hydrograph analysis are listed below (and described in more detail in this section):

- Design storm hyetograph
- Runoff parameters
- Hydrograph synthesis
- Hydrograph routing
- Hydrograph summation

4-4.6.1 Design Storm Hyetograph

The SBUH method requires the input of a rainfall distribution or design storm hyetograph. The design storm hyetograph is rainfall depth versus time for a given design storm frequency and duration. For this application, it is presented as a dimensionless table of unit rainfall depth (incremental rainfall depth for each time interval divided by the total rainfall depth) versus time.

For projects in eastern Washington, the design storms are as noted in [Tables 3-4 and 3-7](#). (The design storms are discussed further in Appendix 4C.) The design storm precipitation depths for the city that is closest to the project site should be selected for use in the SBUH modeling (see Appendix 4A). Another method for obtaining rainfall depths for different storms is to use isopluvial maps (contours of precipitation for a particular storm duration and recurrence interval). The National Weather Service publishes isopluvial maps for different storm durations and recurrence intervals. This information is referenced in Appendix 4A and can also be obtained from the HQ Hydraulics Office.

4-4.6.2 Runoff Parameters

The SBUH method requires input of parameters that describe physical drainage basin characteristics. These parameters provide the basis from which the runoff hydrograph is developed. This section describes the three key parameters (TDA and contributing drainage basin areas; runoff curve number; and runoff time of concentration) that, when combined with the rainfall hyetograph in the SBUH method, develop the runoff hydrograph.

Threshold Discharge Area (TDA) and Contributing Drainage Basin Areas

The proper selection and delineation of the TDA and contributing drainage basin areas (within the TDA) to the BMP or structure of interest is required in the hydrograph analysis. The contributing basin area(s) used should be relatively homogeneous in land use and soil type. If the entire contributing basin is similar in these aspects, the basin can be analyzed as a single area. If significant differences exist within a given contributing drainage basin, it must be divided into subbasin areas of similar land use and soil characteristics. Hydrographs should then be computed for each subbasin area and summed to form the total runoff hydrograph for the basin. Contributing drainage basins larger than 100 acres should be divided into subbasins. By dividing large basins into smaller subbasins and then combining calculated flows, the timing aspect of the generated hydrograph is typically more accurate. For more details on delineation of TDAs, see Section 4-2.5, and for strategies on separating on-site and off-site flow, see Section 4-3.6.1.

Curve Numbers

The NRCS has conducted studies into the runoff characteristics of various land types. After gathering and analyzing extensive data, the NRCS developed relationships between land use, soil type, vegetation cover, interception, infiltration, surface storage, and runoff. The relationships have been characterized by a single runoff coefficient called a curve number (CN). CNs are chosen to depict average conditions—neither dry, nor saturated. The designer is referred to FHWA Ip-80-1 for more information on choosing appropriate curve numbers. Appendix 4B shows suggested CN values for various land covers and soil conditions.

The factors that contribute to the CN value are known as the soil-cover complex. The soil-cover complexes have been assigned to one of four hydrologic soil groups, according to their runoff characteristics. These soil groups are labeled Types A, B, C, and D; with Type A generating the least amount of runoff and Type D generating the greatest. Appendix 4B shows the hydrologic soil groups of most soils in Washington State. The different soil groups can be described as follows:

- **Type A** – Soils having high infiltration rates, even when thoroughly wetted, and consisting chiefly of deep, well-drained to excessively drained sands or gravels. These soils have a high rate of water transmission.
- **Type B** – Soils having moderate infiltration rates when thoroughly wetted and consisting chiefly of moderately fine to moderately coarse textures. These soils have a moderate rate of water transmission.
- **Type C** – Soils having slow infiltration rates when thoroughly wetted and consisting chiefly of soils with a layer that impedes downward movement of water or soils with moderately fine to fine textures. These soils have a slow rate of water transmission.

- **Type D** – Soils having very slow infiltration rates when thoroughly wetted and consisting chiefly of clay soils with a high swelling potential, soils with a permanent high water table, soils with a hardpan or clay layer at or near the surface, and shallow soils over bedrock or other nearly impervious material. These soils have a very slow rate of water transmission.

The NRCS (formerly the Soil Conservation Service, or SCS) has developed maps for Washington State that show the specific soil classification for any given location. These maps are compiled by county and are typically available from the regional NRCS office. To determine which soil group to use for an analysis, locate the project site on the SCS map and read the soil classification listed. (See Appendix 4B for a web link to data to convert from the specific soil classification to a hydrologic soil group.) The WSDOT Materials Lab can also perform a soil analysis to determine the soil group for the project site. This should be done only if an SCS soils map cannot be located for the county in which the site is located; the available SCS map does not characterize the soils at the site (many SCS maps show “urban land” in highway rights of way and other heavily urbanized areas where the soil properties are uncertain); or there is reason to doubt the accuracy of the information on the SCS map for the particular site.

When performing an SBUH analysis for a basin, it is common to encounter more than one soil type. If the soil types are fairly similar (within 20 CN points), a weighted average can be used. If the soil types are significantly different, the basin should be separated into smaller subbasins (previously described for different land uses).

Pervious ground cover and impervious ground cover should always be analyzed separately. If the computer program StormShed is used for the analysis, pervious and impervious land segments will automatically be separated, but the designer will have to combine and manually weight similar pervious soil types for a basin.

Antecedent Moisture Condition

The moisture condition in a soil at the onset of a storm event, referred to as the antecedent moisture condition (AMC), has a significant effect on both the volume and rate of runoff. Recognizing this, the SCS developed three antecedent soil moisture conditions: I, II, and III.

- AMC I:** Soils are dry, but not to the wilting point.
- AMC II:** Average conditions.
- AMC III:** Heavy rainfall, or light rainfall and low temperatures, has occurred within the last 5 days, near saturated or saturated soil.

Table 4-6 gives seasonal rainfall limits for the three antecedent soil moisture conditions.

Table 4-6. Total 5-day antecedent rainfall (inches).

AMC	Dormant Season	Growing Season
I	Less than 0.5	Less than 1.4
II	0.5 to 1.1	1.4 to 2.1
III	Over 1.1	Over 2.1

Varying antecedent moisture conditions are used in the design of evaporation ponds in Chapter 5. (Appendix 4C provides further information.) Refer to Appendix 4B for the curve number conversions for different antecedent moisture conditions for the case of $I_a = 0.2S$. For other conversions, see SCS National Engineering Handbook No. 4, 1985.

Time of Concentration

Travel time (T_t) is the time it takes water to travel from one location to another in a watershed. T_t is a component of time of concentration (T_C), which is the time it takes for runoff to travel from the hydraulically most distant point of the watershed. T_C is computed by summing all the travel times for consecutive components of the drainage flow path. T_C influences the shape and peak of the runoff hydrograph. Urbanization usually decreases T_C , thereby increasing peak discharge. Note: The analysis detailed in this section can be performed using StormShed.

Water moves through a watershed as sheet flow, shallow concentrated flow, open channel flow, or some combination of these. The type of flow that occurs is best determined by field inspection.

Sheet flow is flow over plane surfaces. It usually occurs in the headwater areas of streams and also for short distances on evenly graded slopes. With sheet flow, the friction value (n_s) (a modified Manning's roughness coefficient) is used. These n_s values are for very shallow flow depths of about 0.1 foot (3 cm) and are used only for travel lengths up to 300 feet (90 m). Appendix 4B gives Manning's n_s values for sheet flow for various surface conditions.

For sheet flow of up to 300 feet, use Manning's kinematic solution to directly compute T_t :

$$T_t = (0.42 (n_s L)^{0.8}) / ((P_2)^{0.527} (s_o)^{0.4}) \quad (4-1)$$

where: T_t = travel time (minutes)

n_s = sheet flow Manning's coefficient (dimensionless)

L = flow length (feet)

P_2 = 2-year, 24-hour rainfall (inches)

s_o = slope of hydraulic grade line (land slope, ft/ft)

After a maximum of 300 feet, sheet flow is assumed to become shallow concentrated flow. The average velocity for this flow can be calculated using the k_s values from Appendix 4B. Average velocity is a function of watercourse slope and type of channel. After computing the average velocity using the Velocity Equation (Equation 4-2), the travel time (T_t) for the shallow concentrated flow segment can be computed by dividing the length of the segment by the average velocity.

Open channels are assumed to begin where surveyed cross section information has been obtained, where channels are visible on aerial photographs, or where lines indicating streams appear on USGS Quadrangle maps. For developed drainage systems, the travel time of flow in a pipe is also represented as an open channel. The k_c values from Appendix 4B used in the Velocity Equation can be used to estimate average flow velocity. Average flow velocity is usually determined for bank full conditions. After average velocity is computed, the travel time (T_t) for the channel segment can be computed by dividing the length of the channel segment by the average velocity.

A commonly used method of computing average velocity of flow, once it has measurable depth, is the following Velocity Equation:

$$V = (k)(s_o)^{0.5} \quad (4-2)$$

where: V = velocity (ft/s)

k = time of concentration velocity factor (ft/s)

s_o = slope of flow path (ft/ft)

When estimating travel time (T_t), the following limitations apply:

- Manning's kinematic solution should not be used for sheet flow longer than 300 feet.
- The equations given here to calculate velocity were developed by empirical means; therefore, English Units (such as inches) must be used for all input variables for the equation to yield a correct answer. Once the velocity is calculated, it can be converted to metric units to finish the travel time calculations in the case of shallow concentrated flow and channel flow.

Appendix 4B shows suggested “ n ” and “ k ” values for various land covers to be used in travel time calculations.

4-4.6.3 Hydrograph Synthesis

The SBUH method applies the selected CNs to SCS equations to compute soil absorption and precipitation excess from the rainfall hyetograph. Each time step of this process generates one increment of an instantaneous hydrograph with the same duration. The instantaneous hydrograph is then routed through an imaginary reservoir, with a time delay equal to the basin time of concentration. The end product is the runoff hydrograph for that land segment.

Abstractions (including rainfall interception and storage in small depressions in the ground surface) are also accounted for in the SBUH method. The abstraction of runoff, S , is computed from the CN as follows:

$$S = (1000/CN) - 10 \quad (4-3)$$

Using the abstraction value and precipitation for the given time step, the runoff depth, D , per unit area is calculated as follows:

$$D(t) = \frac{((p(t) - 0.2(S))^2)/(p(t) + 0.8(S))}{2} \quad (4-4)$$

where: $p(t)$ = precipitation for the time increment (in)

The total runoff, $R(t)$, for the time increment is computed as follows:

$$R(t) = D(t) - D(t-1) \quad (4-5)$$

The instantaneous hydrograph, $I(t)$, in cubic feet per second (cfs) at each time step, dt , is computed as follows:

$$I(t) = 60.5 R(t) A/dt \quad (4-6)$$

where: A = area (acres)

dt = time interval (min)

Note: A time interval of 10 minutes or 5 minutes can be used for the Type 1A storm or the Regional Long-Duration Storm, and 5 minutes can be used for the Short-Duration Storm.

The runoff hydrograph, $Q(t)$, is then obtained by routing the instantaneous hydrograph $I(t)$ through an imaginary reservoir with a time delay equal to the time of concentration of the drainage basin. The following equation estimates the routed flow, $Q(t)$:

$$Q(t+1) = Q(t) + w[I(t) + I(t+1) - 2Q(t)] \quad (4-7)$$

where: $w = dt/(2Tc + dt)$

Tc = Time of concentration for the TDA or contributing drainage basin area

4-4.6.4 Level Pool Routing

This section presents the methodology for routing a hydrograph through a stormwater facility using hydrograph analysis. Level pool routing is done the same way regardless of the method used to generate the hydrograph; therefore, this part of the analysis is not unique to the SBUH method. The level pool routing technique presented here is one of the simplest and most commonly used hydrograph routing methods and is the method used in StormShed. It is based on the following continuity equation:

$$\begin{aligned} \text{Inflow} - \text{Outflow} &= \text{Change in Storage} \\ ((I_1 + I_2)/2) - ((O_1 + O_2)/2) &= S_2 - S_1 \end{aligned} \quad (4-8)$$

where: I_1, I_2 = Inflow at time 1 and time 2
 O_1, O_2 = Outflow at time 1 and time 2
 S_1, S_2 = Storage at time 1 and time 2

The time interval for the routing analysis must be consistent with the time interval used in developing the inflow hydrograph. The time interval used for a 24-hour storm is 10 minutes. The variables can be rearranged to obtain the following equation:

$$I_1 + I_2 + 2S_1 - O_1 = O_2 + 2S_2 \quad (4-9)$$

If the time interval is in minutes, the unit of storage (S) is now cubic feet per minute (cf/min), which can be converted to cfs by multiplying by 1 min/60 sec.

The terms on the left-hand side of the equation are known from the inflow hydrograph and from the storage and outflow values of the previous time step. The unknowns O and S can be solved interactively from the given stage-storage and stage-discharge curves. As with the synthesis of a hydrograph, the computations are fairly simple, but very voluminous. The best way to route a hydrograph through a stormwater facility is to use a computer program. Many hydrologic analysis software programs include features that make hydrograph routing an easy process.

4-4.6.5 Hydrograph Summation

One of the key advantages of hydrograph analysis is the ability to accurately describe the cumulative effect of runoff from several contributing drainage basin areas (within one TDA) having different runoff characteristics and travel times. This cumulative effect is best characterized by a single hydrograph, which is obtained by summing the individual hydrographs from tributary basins at a particular discharge point of interest.

The general procedure for performing a hydrograph summation begins with selecting a discharge point of interest where it is important to know the effects of the runoff generated on the project site. Next, route each individual hydrograph through a conveyance system that carries it to the point of interest. The final step is to sum the flow values for each hydrograph for all of the time intervals. This will yield a single discharge hydrograph.

4-4.7 Eastern Washington Design Storm Events

When rainfall patterns during storms were analyzed in eastern Washington, it was concluded that the SCS Type II rainfall does not match the historical records. Two types of storms were found to be prominent on the east side of the state: short-duration thunder storms (later spring through early fall seasons) and long-duration winter storms (any time of year, but most common in the late fall through winter period and the late spring and early summer period). The short-duration storm generates the greatest peak discharges and should be used to design flow-based BMPs. The long duration storm occurs over several days, generating the greatest volume, and should be used to design volume-based BMPs.

When using the long-duration storm, it should be noted that the state has been divided into the following four climatic regions:

1. East Slope Cascades
2. Central Basin
3. Okanogan, Spokane, Palouse
4. NE and Blue Mountains

The long-duration storms in Regions 2 and 3 are similar to the SCS Type 1A storm. Designers in those regions can choose to use either the long-duration storm or the SCS Type 1A storm. Eastern Washington design storm events are further discussed in Appendix 4C.

4-4.8 Modeling Using Low-Impact Development Techniques in Eastern Washington

Low-impact development (LID) is a BMP application that manages stormwater on a small scale and disperses it into a facility as close as possible to the source of runoff. This is in contrast to conventional BMP applications that manage stormwater at one location on the project site.

Design of low-impact development BMP drainage features in eastern Washington requires a different approach than in western Washington, since the sizing of these systems is based on a single-event hydrologic model. Adjustments to site runoff parameters are based on the SCS Curve Numbers (CNs) applicable to the site ground cover and soil conditions. Appendix 4B presents the adjusted runoff CNs for selected soil and ground cover combinations, reflecting the reduced values for situations where pervious areas drain to low-impact BMPs. (See Section 4-4.6.2 for soil type definitions and more discussion on CN values.) Note: The analysis described in this section generally uses StormShed.

Composite custom CN values are calculated using a weighted approach based on individual land covers, without considering disconnectivity of the site's impervious surfaces. This approach is appropriate because it places increased emphasis on minimal disturbance to, and retention of, site areas that have potential for runoff storage and infiltration. This approach also provides an incentive to save more trees and shrubs and maximize the use of Type A and B soils for recharge.

If the impervious surface coverage on the site is less than 30% of the site area, the percentage of unconnected impervious areas within the watershed influences the calculation of the CN value. For linear transportation systems, the percentage of impervious surface should be evaluated based on a "unit length" method, such as a drainage area 30 feet wide that is bound by the crown of the roadway centerline to the right of way limit.

Use Equation 4-10 when disconnectivity of impervious areas is not considered.

$$CN_c = \frac{CN_1A_1 + CN_2A_2 \dots + CN_jA_j}{A_1 + A_2 \dots + A_j} \quad (4-10)$$

where: CN_c = Composite Curve Number

A_j = Area of each land cover in ft^2

CN_j = Curve number for each land cover

Use Equation 4-11 for sites with less than 30% impervious surface coverage where those impervious surfaces are disconnected.

$$CN_c = CN_p + \left(\frac{P_{imp}}{100} \right) x (98 - CN_p) x (1 - 0.5R) \quad (4-11)$$

where: CN_c = Composite Curve Number

CN_p = Composite pervious Curve Number

P_{imp} = Percentage impervious site area

R = Ratio of unconnected impervious area to total impervious area

Unconnected impervious areas are impervious areas without any direct connection to a drainage system or other impervious surface.

After calculation of the CN_c is complete, use the SBUH method to determine stormwater runoff volumes and rates from the unit length of roadway basin (for example, 30-foot width for continuous roadway prisms with consistent soils/vegetation) for the applicable runoff treatment and flow control design storms. This method can also be applied to specific roadway lengths (noncontinuous width) where soils and roadway character vary.

It is extremely important to verify soil infiltration capacity and vegetative cover in all areas where the SBUH method is to be applied. Determine the natural infiltration capacity of the roadside area where runoff will be distributed. The WSDOT Materials Lab should provide the infiltration rates, although initial estimates based on published NRCS data can be used for rough sizing estimates (see [Section 4-5.3](#)). If the resultant infiltration rate (Q) of the receiving area is greater than the peak 25-year design flow rate of the contributing drainage basin, all stormwater will be infiltrated along the roadside and no further analysis is needed. Calculation of the infiltrative flow rate, Q_i , can be performed as follows:

Calculation of Infiltrative Flow Rate

$$Q_i = \frac{F \times A}{43200 \frac{in/hr}{ft/s}}$$

where: Q_i = Flow rate in cfs

A = Area available for infiltration in ft^2

F = Saturated (long-term) infiltration rate in inches/hour

Should peak flow rates of the contributing drainage basin exceed the infiltrative flow rate of the receiving roadside area, further analysis is required and some storage of stormwater will be necessary. In semiarid nonurban areas, formalized detention ponds are usually not the best solution. Storage of minor to moderate amounts of stormwater runoff can be accomplished by using natural depression storage. This includes depressions in the roadside topography, swales, and even roadway ditches. Each of these features can accommodate stormwater storage and allow for releasing runoff through infiltration over a longer time scale.

To determine the needed runoff retention volume, subtract the continuous saturated infiltration rate from the 25-year storm hydrograph produced from the SBUH method. The resulting quantity represents the runoff volume that needs to be detained until infiltration can “catch up” with the runoff. Check to see if this volume can be accommodated in the existing roadside landscape or roadway ditches. If roadside hydraulic conveyance capacity allows, *check dams* may be placed in ditches to detain stormwater in noncentralized locations. This method for small-scale flow detention will require a site-specific analysis; a continuous linear approach may not be valid.

4-5 Infiltration Design Criteria

An infiltration facility provides stormwater flow control by containing excess runoff in a storage facility, then percolating that runoff into the surrounding soil. Infiltration facilities can provide runoff treatment and flow control, but to do so requires certain soil characteristics. Section 4-5.1, Site Suitability Criteria, provides a detailed discussion of soil characteristics needed to determine which type of infiltration facility is most appropriate for the site.

There are many types of infiltration BMPs listed in Chapter 5. Some of these facilities include ponds, vaults, trenches, and drywells, along with partial infiltration facilities such as natural and engineered dispersion and compost-amended vegetated filter strips (CAVFS). This section provides design criteria on the various ways to determine infiltration rates and facility size, dependent on the facility and whether infiltration occurs at the surface or below the surface (subsurface).

Surface infiltration BMP designs and subsurface infiltration BMP designs follow different criteria. Infiltration ponds, infiltration vaults, infiltration trenches (designed to intercept sheet flow), dispersion, and CAVFS are considered surface infiltration BMPs and are based on infiltration rates. In order to compute these infiltration rates, determination of the soil saturated hydraulic conductivity must be completed. Infiltration trenches designed as an end-

of-pipe application (with underdrain pipe) and drywells are considered subsurface infiltration BMPs and regulated by the Underground Injection Control (UIC) Rule, which is intended to protect underground sources of drinking water. As a result, subsurface infiltration BMPs are known as underground injection facilities and designed dependent on the treatment capacity of the subsurface soil conditions.

The sections that follow provide detailed information on site suitability criteria, saturated hydraulic conductivity determination, determination of infiltration rates, and underground injection facilities.

4-5.1 Site Suitability Criteria (SSC)

This section specifies the site suitability criteria that must be considered for siting infiltration treatment systems. When a site investigation reveals that any of the following eight applicable criteria cannot be met, appropriate mitigation measures must be implemented so that the infiltration facility will not pose a threat to safety, health, or the environment.

For infiltration treatment, site selection, and design decisions, a qualified engineer with geotechnical and hydrogeologic experience should prepare a geotechnical and hydrogeologic report. A comparable professional may also conduct the work if it is under the seal of a registered Professional Engineer (PE). The design engineer may use a team of certified or registered professionals in soil science, hydrogeology, geology, and other related fields.

To design infiltration facilities, the following SSC must be followed when applicable, in addition to those described in the BMP descriptions.

SSC 1 – Setback Requirements

Setback requirements for infiltration facilities are generally provided in local regulations, Uniform Building Code requirements, or other state regulations. The following setback criteria are used unless otherwise required by Critical Area Ordinance or other jurisdictional authorities.

- In general, infiltration facilities should be located 20 feet downslope and 100 feet upslope from building foundations and 50 feet or more behind the top of slopes steeper than 15%. The designer should request a geotechnical report for the project that would evaluate structural site stability impacts due to extended subgrade saturation and/or head loading of the permeable layer, including the potential impacts to downgradient properties (especially on hills with known side-hill seeps). The report should address the adequacy of the proposed BMP locations and recommend any adjustments to the setback distances provided above, either greater or smaller, based on the results of this evaluation.
- Infiltration facilities should be set back at least 100 feet from drinking water wells, septic tanks or drain fields, and springs used for public drinking water

- supplies. Infiltration facilities upgradient of drinking water supplies and within 1-, 5-, and 10-year time of travel zones must comply with health department requirements (Washington Wellhead Protection Program, WAC 246-290-135).
- Additional setbacks must be considered if roadway deicers or herbicides are likely to be present in the influent to the infiltration system.
 - Infiltration facilities must be located at least 20 feet from a native growth protection easement (NGPE).
 - Infiltration facilities must be a minimum of 5 feet from any property line and vegetative buffer. This distance may be increased based on permit conditions required by the local government.

SSC 2 – Seepage Analysis and Control

Determine whether there would be any adverse effects caused by seepage zones near building foundations, roads, parking lots, or sloping sites. Infiltration of stormwater is not recommended on or upgradient of a contaminated site where infiltration of even clean water can cause contaminants to mobilize.

Sidewall seepage is not usually a concern if seepage occurs through the same stratum as the bottom of the facility. However, for engineered soils or soils with very low permeability, the potential to bypass the treatment soil through the sidewalls may be significant. In those cases, the sidewalls must be lined, either with an impervious liner or with at least 18 inches of treatment soil, to prevent seepage of untreated flows through the sidewalls.

SSC 3 – Groundwater Protection Areas

A site is not suitable if the infiltrated stormwater will cause a violation of the Ecology water quality standards for ground waters (WAC 173-200). Local jurisdictions should be consulted to determine applicable pretreatment requirements and whether the site is located in an aquifer-sensitive area, a sole-source aquifer, or a wellhead protection zone.

SSC 4 – Depth to Bedrock, Water Table, or Impermeable Layer

The base of all infiltration basins or trench systems must be ≥ 5 feet above the seasonal high-water mark, bedrock (or hardpan), or other low-permeability layer. A separation down to 3-feet may be considered if the design of the overflow and/or bypass structures is judged by the site professional to be adequate to prevent overtopping and meet the SSC specified in this section.

SSC 5 – Soil Infiltration Rate

For runoff treatment infiltration facilities, the short-term soil infiltration rate is 2.4 inches per hour or less, calculated as described in Section 4-5.3.1 using the “Detailed Approach,” but using a value of 1.0 for $CF_{silt/bio}$. The “Simplified Approach” (see Section 4-5.3.2) should not

be used for this determination in western Washington, as it is set up to only produce long-term infiltration rates. The infiltration rate calculated in this manner should not be used to size the facility, but only to determine whether the treatment criterion is met. This infiltration rate is typical for soil textures that possess sufficient physical and chemical properties for adequate treatment, particularly for soluble pollutant removal (see below). It is comparable to the textures represented by Hydrologic Soil Groups B and C (see hydrologic soil groups in Section 4-4.6.2).

Long-term infiltration rates, calculated as described in Section 4-5.3.1 and accounting for long-term effects such as siltation and biofouling (up to 2.0 inches per hour), can also be considered if the infiltration receptor is not a sole-source aquifer and if, in the judgment of the site professional, the treatment soil has characteristics comparable to those specified in SSC 7 to adequately control the target pollutants.

SSC 6 – Drawdown Time

For western Washington, the 91% percentile, 24 hour runoff volume must be infiltrated within 36 hours. Under this premise, the storm/runoff ends 12 hours after the runoff period midpoint and combines with the 24-hour drain criteria. Therefore, the actual drawdown time is 36 hours. Flow control and runoff treatment in eastern Washington is designed to completely drain ponded runoff within 72 hours in order to meet the following objectives:

- Restore hydraulic capacity to receive runoff from a new storm (applicable for single-event modeling, but not applicable for continuous hydrograph modeling).
- Aerate vegetation and soil to keep the vegetation healthy, prevent anoxic conditions in the treatment soil, and enhance the biodegradation of pollutants and organics (if the infiltration facility is to provide treatment).

In general, this drawdown requirement is applicable only if it is intended for the infiltration facility to provide treatment and for addressing storage capacity if a single-event hydrograph model is used. Drawdown time criteria are not applicable for infiltration facilities designed for flow control in western Washington.

SSC 7 – Soil Physical and Chemical Suitability for Treatment

Soil texture and design infiltration rates should be considered, along with the physical and chemical characteristics specified below, to determine whether the soil is adequate for removing the target pollutants. The following soil properties must be carefully considered in making such a determination:

- Cation exchange capacity (CEC) of the treatment soil must be ≥ 5 milliequivalents CEC/100 g dry soil (U.S. EPA Method 9081). *Consider empirical testing of soil sorption capacity, if practicable.* Ensure soil CEC is sufficient for expected pollutant loadings, particularly heavy metals. CEC values of >5 meq/100g are expected in loamy sands, according to Rawls et al. (1982). Lower CEC content may be considered if it is based on a soil loading

capacity determination for the target pollutants that is accepted by the local jurisdiction.

- The sodium adsorption ratio (SAR) can have a dramatic effect on the long-term performance of an infiltration facility. Soils with an excess of sodium ions, compared to calcium and magnesium ions, remain in a dispersed condition, almost impermeable to water. A dispersed soil is extremely sticky when wet, tends to crust, and becomes very hard and cloddy when dry. An SAR value of 15 or greater indicates that an excess of sodium will be adsorbed by the soil clay particles and severely restrict infiltration. Montmorillonite, vermiculite, illite, and mica-derived clays are more sensitive to sodium than other clays and could develop problems if the SAR is greater than 5. If runoff contains high levels of sodium in relation to calcium and magnesium, it may also present problems in the future. The addition of gypsum (calcium sulfate) to the soil can be used to free the sodium and allow it to be leached from the soil.
- Depth of soil used for infiltration treatment must be a minimum of 18 inches, except for designed, vegetated infiltration facilities with an active root zone, such as bioinfiltration swales.
- The organic content of the treatment soil (ASTM D 2974); organic matter can increase the sorptive capacity of the soil for some pollutants. The site professional should evaluate whether the organic matter content is sufficient for control of the target pollutant(s).
- Waste fill materials should not be used as infiltration soil media, nor should such media be placed over uncontrolled or nonengineered fill soils.
- Engineered soils may be used to meet the design criteria in this chapter and the runoff treatment targets in Table 3-1. Field performance evaluation(s), using acceptable protocols, would be needed to determine feasibility and acceptability by the local jurisdiction. (See Soil Amendments in Chapter 5.)

SSC 8 – Cold Climate and Impacts of Roadway Deicers

- For cold climate design criteria (snowmelt/ice impacts), refer to the D. Caraco and R. Claytor document, *Stormwater BMP Design Supplement for Cold Climates*, U.S. EPA, December 1997.
- The potential impact of roadway deicers on potable water wells must be considered in the siting determination. Mitigation measures must be implemented if infiltration of roadway deicers can cause a violation of groundwater quality standards. For assistance, contact region or HQ hydraulics staff.

4-5.2 Saturated Hydraulic Conductivity

Once a site is determined suitable for infiltration, the infiltration design can begin. The sizing of an infiltration BMP is dependent on the infiltration rate of the soils over which the BMP is located. Section 4-5.3 discusses the various ways to determine an infiltration rate. Infiltration rates are based on two components: the soil's saturated hydraulic conductivity and the hydraulic gradient. This section explains how to determine saturated hydraulic conductivity, which is based on the porosity of the underlying soil saturated.

There are two ways to determine saturated hydraulic conductivity. The first methodology, called the Detailed Approach, was developed from research conducted by Massmann (2003). The second methodology is the use of the Guelph Permeameter and is only allowable in eastern Washington.

4-5.2.1 Detailed Approach to Determine Saturated Hydraulic Conductivity

The geotechnical investigation will typically provide a computation of the saturated hydraulic conductivity (K_{sat}) for the area proposed for infiltration. In those cases where the K_{sat} is not provided, the designer can use the gradation information from the geotechnical investigation and the following equations to compute the K_{sat} value.

The K_{sat} derived using the Detailed Approach can then be used to design the following:

- Infiltration pond (BMP IN.02)
- Infiltration trench (BMP IN.03)
- Infiltration vault (BMP IN.04)
- Underlying soils of CAVFS (BMP RT.02)
- Drywell (BMP IN.05)
- Natural dispersion (BMP FC.01)

For each defined layer below the facility to a depth below the facility bottom of 2.5 times the maximum depth of water in the facility, but not less than 6 feet, estimate the K_{sat} (cm/sec) using the following relationship (see Massmann, 2003, and Massmann et al., 2003):

$$\log_{10}(K_{sat}) = -1.57 + 1.90D_{10} + 0.015D_{60} - 0.013D_{90} - 2.08f_{fines} \quad (4-12)$$

where: K_{sat} = the saturated hydraulic conductivity in cm/s
 D_{10} , D_{60} and D_{90} = grain sizes in mm for which 10%, 60%,
and 90% of the sample is more fine
 f_{fines} = grain sizes in mm for the fraction of the soil (by weight)
that passes the number-200 sieve

Use the following equation to convert K_{sat} from cm/s to ft/day:

$$K_{sat} \text{ (ft/day)} = K_{sat} \text{ (cm/s)} \times 2,834.65$$

If the licensed professional conducting the investigation determines that deeper layers will influence the rate of infiltration for the facility, soil layers at greater depths must be considered when assessing the site's saturated hydraulic conductivity characteristics. Massmann (2003) indicates that where the water table is deep, soil or rock strata up to 100 feet below an infiltration facility can influence the rate of infiltration. Note that only the layers near and above the water table or low permeability zone (such as a clay, dense glacial till, or rock layer) need to be considered, as the layers below the groundwater table or low permeability zone do not significantly influence the rate of infiltration. Also, note that this equation for estimating saturated hydraulic conductivity assumes minimal compaction consistent with the use of tracked (low-to-moderate ground pressure) excavation equipment, as described in the Site Design Elements of Section 5-4.2.1.

If the soil layer being characterized has been exposed to heavy compaction, or is heavily overconsolidated due to its geologic history (for example, overridden by continental glaciers), the saturated hydraulic conductivity for the layer could be approximately an order of magnitude less than what would be estimated based on grain size characteristics alone (Pitt, 2003). In such cases, compaction effects must be taken into account when estimating saturated hydraulic conductivity. For clean, uniformly graded sands and gravels, the reduction in K_{sat} due to compaction will be much less than an order of magnitude. For well-graded sands and gravels with moderate-to-high silt content, the reduction in K_{sat} will be close to an order of magnitude. For soils that contain clay, the reduction in K_{sat} could be greater than an order of magnitude.

There are field tests that can estimate specific soil layer K_{sat} values. These tests include the packer permeability test (above or below the water table), the piezocone (below the water table), an air conductivity test (above the water table), and a pilot infiltration test (PIT), as described in Ecology's SMMWW. Note that these field tests generally provide a saturated hydraulic conductivity combined with a hydraulic gradient (see Darcy's Law, Equation 4-18). In some of these field tests, the hydraulic gradient may be close to 1.0. For this condition, Darcy's Law would show that the K_{sat} would be nearly equal to the infiltration rate of that soil layer. It is important to recognize that the gradient in these field tests may not be the same as the gradient likely to occur in the full-scale infiltration facility in the long term (when groundwater mounding is fully developed). This issue will need to be evaluated on a case-by-case basis when interpreting the results of field tests.

For Infiltration Pond, Infiltration Trench, Infiltration Vault, and the underlying soils for CAVFS, once the saturated hydraulic conductivity for each layer has been identified, determine the effective average saturated hydraulic conductivity below the BMP. Saturated hydraulic conductivity estimates from different layers can be combined using the harmonic mean:

$$K_{equiv} = \frac{d}{\sum \frac{d_n}{K_{sat_n}}} \quad (4-13)$$

where: K_{equiv} = the average saturated hydraulic conductivity in ft/day
 d = the total depth of the soil column in feet
 d_n = the thickness of layer “n” in the soil column in feet
 K_{sat_n} = the saturated hydraulic conductivity of layer “n” in the soil column in ft/day

The depth of the soil column, d , typically would include all layers between the BMP bottom and the water table. However, for sites with very deep water tables (>100 feet) where groundwater mounding to the base of the BMP is not likely to occur, it is recommended that the total depth of the soil column in Equation 4-13 be limited to approximately 20 times the depth of BMP. This is to ensure the most important and relevant layers are included in the saturated hydraulic conductivity calculations. Deep layers that are not likely to affect the infiltration rate near the BMP bottom should not be included in Equation 4-13. Equation 4-13 may overestimate the effective saturated hydraulic conductivity value at sites with low conductivity layers immediately beneath the infiltration BMP. For sites where the lowest conductivity layer is within 5 feet of the base of the BMP, it is suggested that this lowest saturated hydraulic conductivity value be used as the equivalent saturated hydraulic conductivity rather than the value from Equation 4-13. The harmonic mean given by Equation 4-13 is the appropriate effective saturated hydraulic conductivity for flow that is perpendicular to stratigraphic layers and will produce conservative results when flow has a significant horizontal component (such as could occur with groundwater mounding).

For the soils underlying a CAVFS, a correction factor should be applied to the saturated hydraulic conductivity to account for compaction in the embankment. A correction factor of 10 (1/10th of the estimated K_{sat} determined by Equation 4-12) should be used for “well-graded sands and gravels with moderate-to-high silt content.” For clean, uniformly graded sands and gravels, a correction factor of 5 should be used, and a correction factor of 15 should be applied to K_{sat} for soils that contain clay.

- **Alternate method of determining the saturated hydraulic conductivity (K_{sat}) for CAVFS**

Refer to Ecology’s SMMWW, Volume III, Appendix III-D, Procedure for Conducting a Pilot Infiltration Test. A correction factor of 1.5 to 6 should be applied to the measured infiltration rate (f) determined by this method. A correction factor on the lower end of the range should be applied to the infiltration rate if the designer can verify that the underlying fill material being tested is relatively consistent for the length of proposed CAVFS. Otherwise, a reduction factor toward the higher end of the range should be used. K_{sat} can be determined by using Equation 4-12. The hydraulic gradient will need to be established for the CAVFS area.

For drywells, once the saturated hydraulic conductivity for each layer has been identified, the designer must convert the saturated hydraulic conductivity to (ft/min) and then calculate the geometric mean of the multiple saturated hydraulic conductivity values.

The geometric mean for saturated hydraulic conductivity value is given by the following expressions:

$$K_{\text{geometric}} = e^{Y_{\text{average}}} \quad (4-14)$$

where: $K_{\text{geometric}}$ = the average saturated hydraulic conductivity in ft/min
 Y_{average} = the average of the natural logarithms of the hydraulic conductivity values:

$$Y_{\text{average}} = \frac{1}{n} \sum Y_i = \frac{1}{n} \sum \ln(K_i) \quad (4-15)$$

where: K_i = the saturated hydraulic conductivity of soil layer i in ft/min
 Y_i = the natural logarithms of the saturated hydraulic conductivity values

4-5.2.2 Determining Saturated Hydraulic Conductivity Using the Guelph Permeameter

The K_{sat} derived using the Guelph Permeameter can then be used to design:

- Natural dispersion for eastern Washington only (FC.01)

The determination of an appropriate K_{sat} measurement protocol is essential for the proper implementation of the *natural dispersion* BMP on the embankment. Equally, accurate K_{sat} measurements are one of the most challenging aspects in hydrologic modeling, particularly for surface infiltration methods. The following method can be used in eastern Washington only.

In cases when the existing embankments will, for the most part, remain in place with little disturbance or additional embankment construction (minor shoulder widening), the Guelph Permeameter (GP) method should be used to determine the in situ K_{sat} values. Once a value has been established, a correction factor of 2 should be applied to K_{sat} for the natural dispersion design.

- The recommended testing frequency should be 5 tests per 2500 linear feet of roadway, with the average value of all tests representing the design K_{sat} value. This recommendation is based on the premise that existing roadway embankments were constructed with imported fill material hauled from off-site borrow sites. If the designer wants to limit the number of test holes needed, it would be necessary to conduct a review of all as-built information and any other relevant design records to determine where placement of

- borrow material has occurred. If it is determined that consecutive segments of the subject highway were constructed from the same materials source, then no additional testing outside the recommended frequency would be necessary.
- The GP method provides simultaneous in situ measurements in the vadose zone of field-saturated hydraulic conductivity sorptivity and the hydraulic conductivity pressure head relationship. The method involves measuring the steady-state rate of water recharge from a small cylindrical hole in which a constant depth of water is maintained. A simple “in-hole” bottle device is used to establish and maintain the depth to measure the corresponding discharge rate.

4-5.3 Determination of Infiltration Rates

An overview of the design procedure is provided in Figures 4-14 through 4-16. The focus of these design procedures is to size the facility. For other geotechnical aspects of the facility design, including geotechnical stability of the facility and constructibility requirements, see Chapter 5 and the *Design Manual*. A multidisciplinary approach is required to design infiltration facilities, as described in Chapter 2. This section describes the three methods for determining infiltration rates.

1. **Detailed Approach for determining infiltration rates.** A detailed analysis that allows the designer to consider the type of hydrograph used (continuous or single-event); the depth to the groundwater table; the site-specific hydraulic gradient for the facility; and the facility geometry.
2. **Simplified Approach for determining infiltration rates.** This method generally follows Ecology’s SMMWW and commonly produces a more conservative facility size.
3. **Determining Infiltration Rates for Soil Amendments.** This method follows a standard ASTM and has been accepted by Ecology.

4-5.3.1 Detailed Approach for Determining Infiltration Rates

This Detailed Approach was obtained from Massmann (2003) and should be used for infiltration pond, infiltration vault, and the underlying soils of a CAVFS design. Procedures for the Detailed Approach are as follows (see Figures 4-14 and 4-15 for a process flowchart):

1. **Select a location.**

This will be based on the ability to convey flow to the location and the expected soil conditions. The minimum setback distances must also be met. (See Section 4-5.1 for Site Suitability Criteria and setback distances.)

2. Estimate volume of stormwater, V_{design} .

For eastern Washington, a single-event hydrograph or value for the volume can be used, allowing a modeling approach such as StormShed to be conducted. For western Washington, a continuous hydrograph should generally be used, requiring a model such as MGSFlood to perform the calculations. (See Section 4-3 for western Washington and Section 4-4 for eastern Washington methodologies.)

3. Develop a trial infiltration facility geometry based on length, width, and depth.

To accomplish this, either assume an infiltration rate based on previously available data or use a default infiltration rate of 0.5 inches/hour. This trial geometry should be used to help locate the facility and for planning purposes in developing the geotechnical subsurface investigation plan.

4. Conduct a geotechnical investigation.

A geotechnical investigation must be conducted to evaluate the site's suitability for infiltration; to establish the infiltration rate for design; and to evaluate slope stability, foundation capacity, and other geotechnical design information needed to design and assess the constructibility of the facility. Geotechnical investigation requirements are provided below.

The depth, number of test holes or test pits, and sampling described below should be increased if a licensed engineer with geotechnical expertise (P.E.), or other licensed professional acceptable to WSDOT, judges that conditions are highly variable and make it necessary to increase the depth or the number of explorations to accurately estimate the infiltration system's performance. The exploration program described below may be decreased if a licensed engineer with geotechnical expertise (P.E.), or other licensed professional acceptable to WSDOT, judges that conditions are relatively uniform; design parameters are known to be conservative based on site-specific data or experience; and the borings/test pits omitted will not influence the design or successful operation of the facility.

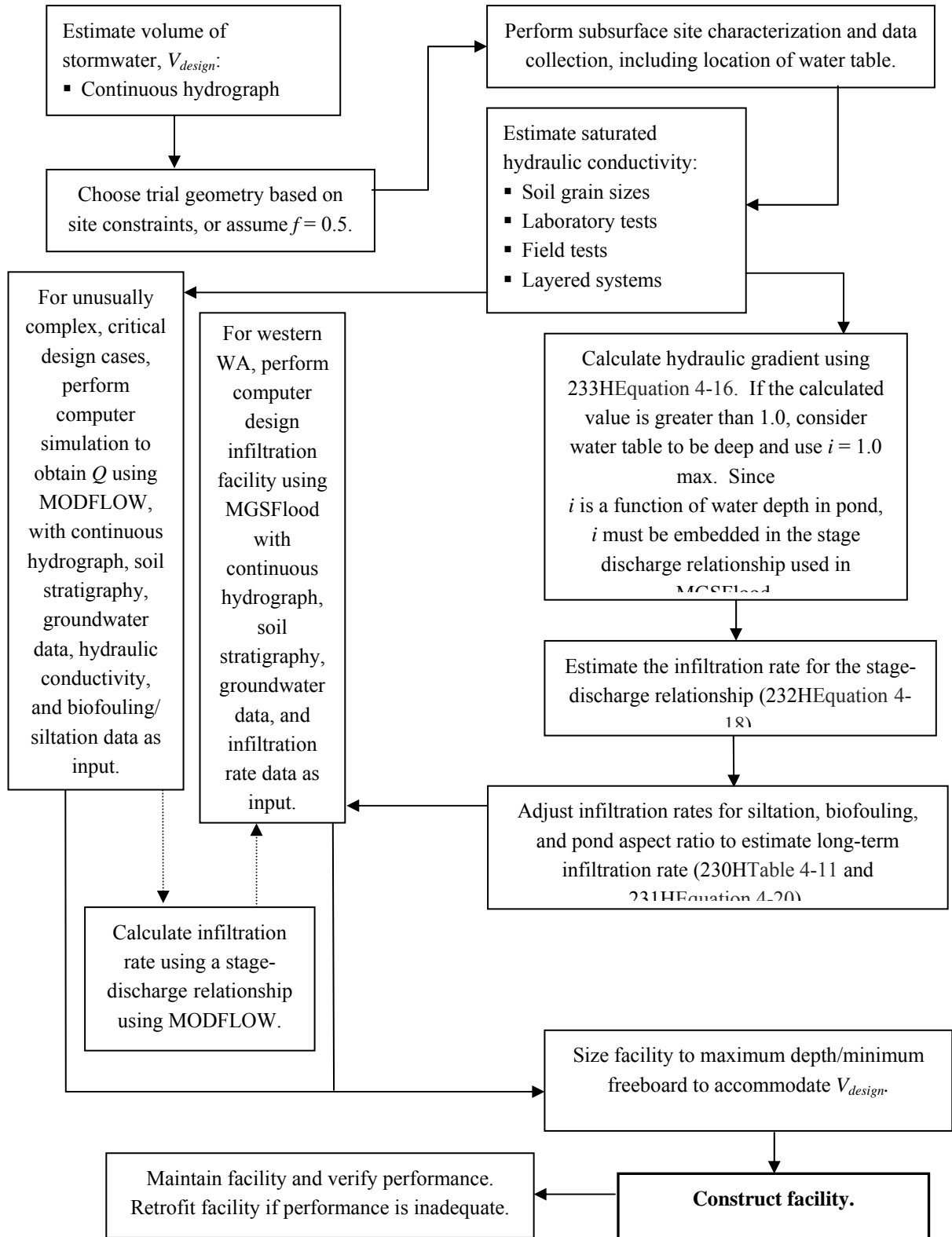

Figure 4-14. Engineering design steps for final design of infiltration facilities using the continuous hydrograph method (western Washington).

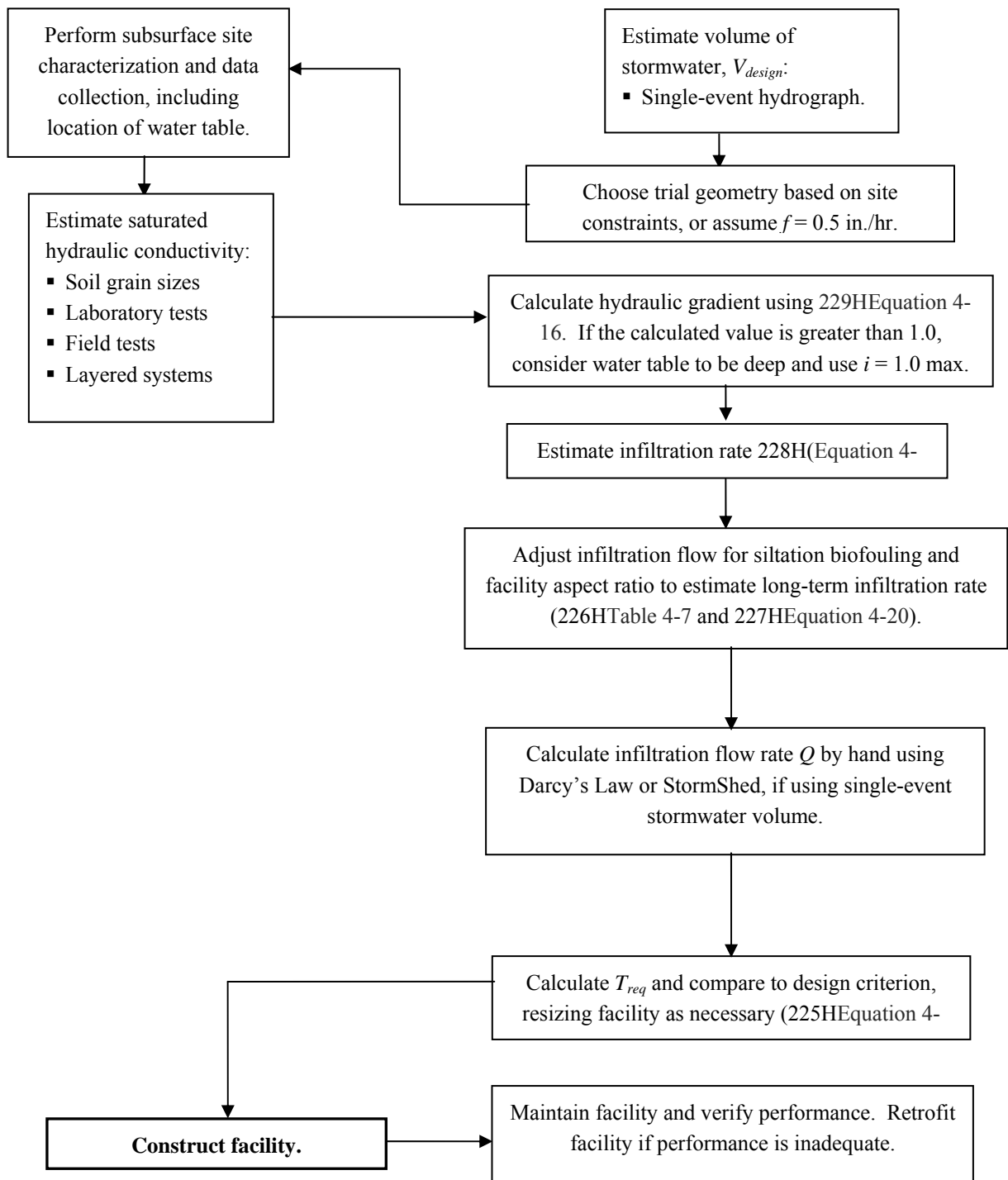

Figure 4-15. Engineering design steps for final design of infiltration facilities using the single-event hydrograph method (eastern Washington).

- For infiltration ponds, at least one test pit or test hole per 5,000 ft² of basin infiltrating bottom surface area.
- For infiltration trenches, infiltration vaults, and CAVFS, at least one test pit or test hole per 100 to 300 feet of length.
- For drywells, samples should be collected from each layer beneath the facility to the depth of groundwater or to approximately 40 feet below the ground surface (approximately 30 feet below the base of the drywell). Subsurface explorations (test holes or test pits) to a depth below the base of the infiltration facility of at least 5 times the maximum design depth of water proposed for the infiltration facility, or at least 2 feet into the saturated zone.
- Continuous sampling to a depth below the base of the infiltration facility of 2.5 times the maximum design depth of water proposed for the infiltration facility, or at least 2 feet into the saturated zone, but not less than 6 feet. Samples obtained must be adequate for the purpose of soil gradation/classification testing.
- Groundwater monitoring wells installed to locate the groundwater table and establish its gradient, direction of flow, and seasonal variations, considering both confined and unconfined aquifers. (Monitoring through at least one wet season is required unless site historical data regarding groundwater levels are available.) In general, a minimum of three wells per infiltration facility, or three hydraulically connected surface or groundwater features, are needed to determine the direction of flow and gradient. If gradient and flow direction are not required and there is low risk of downgradient impacts, one monitoring well is sufficient. Alternative means of establishing the groundwater levels may be considered. If the groundwater in the area is known to be greater than 50 feet below the proposed facility, detailed investigation of the groundwater regime is not necessary.
- Laboratory testing as necessary to establish the soil gradation characteristics and other properties to complete the infiltration facility design. At a minimum, one grain-size analysis per soil stratum in each test hole must be conducted within 2.5 times the maximum design water depth, but not less than 6 feet. When assessing the saturated hydraulic conductivity characteristics of the site, soil layers at greater depths must be considered if the licensed professional conducting the investigation determines that deeper layers will influence the rate of infiltration for the facility, requiring soil gradation/classification testing for layers deeper than indicated above.

5. **From the geotechnical investigation, determine the following, as applicable:**

- The stratification of the soil/rock below the infiltration facility, including the soil gradation (and plasticity, if any) characteristics of each stratum.
- The depth to the groundwater table and to any bedrock/impermeable layers.
- Seasonal variation of the groundwater table.
- The existing groundwater flow direction and gradient.
- The saturated hydraulic conductivity or the infiltration rate for the soil/rock at the infiltration facility.
- The porosity of the soil below the infiltration facility, but above the water table.
- The lateral extent of the infiltration receptor.
- The impact of the infiltration rate and volume on flow direction and water table at the project site and the potential discharge point or area of the infiltrating water.

For other aspects of the geotechnical design of infiltration facilities, see Chapters 2 and 5.

6. **Determine the saturated hydraulic conductivity as noted in Section 4-5.2.**

7. **For unusually complex, critical design cases, develop input data for a simulation model.**

Use **MODFLOW**, including trial geometry, continuous hydrograph data, soil stratigraphy, groundwater data, saturated hydraulic conductivity data, and reduction in saturated hydraulic conductivity due to siltation or biofouling on the surface of the facility. Use of this approach will generally be fairly rare. If necessary, the design office should contact consulting services for help in locating an appropriate resource to complete a MODFLOW analysis. Otherwise, skip this step and develop the data needed to estimate the hydraulic gradient, as shown in the following steps.

8. **Calculate the hydraulic gradient.**

The steady state hydraulic gradient is calculated as follows:

$$\text{gradient} = i \approx \frac{D_{wt} + D_{pond}}{138.62(K_{equiv}^{0.1})} CF_{size} \quad (4-16)$$

where: i = steady state hydraulic gradient
 D_{wt} = the depth from the base of the infiltration facility to the

- water table in feet
- K_{equiv} = the average saturated hydraulic conductivity in feet/day
- D_{pond} = the depth of water in the facility in feet (see Massmann et al., 2003, for the development of this equation)
- CF_{size} = the correction for pond size

The correction factor was developed for ponds with bottom areas between 0.6 and 6 acres in size. For small ponds (ponds with area equal to 2/3 acre), the correction factor is equal to 1.0. For large ponds (ponds with area equal to 6 acres), the correction factor is 0.2, as shown in Equation 4-17.

$$CF_{size} = 0.73(A_{pond})^{-0.76} \quad (4-17)$$

where: A_{pond} = the area of pond bottom in acres

This equation will generally result in a calculated gradient of less than 1.0 for moderate-to-shallow groundwater depths (or to a low permeability layer) below the facility and conservatively accounts for the development of a groundwater mound. A more detailed groundwater mounding analysis, using a program such as MODFLOW, will usually result in a gradient that is equal to or greater than the gradient calculated using Equation 4-16. If the calculated gradient is greater than 1.0, the water table is considered to be deep and a maximum gradient of 1.0 must be used.

Typically, a depth to groundwater of 100 feet or more is required to obtain a gradient of 1.0 or more using this equation. Since the gradient is a function of depth of water in the facility, the gradient will vary as the pond fills during the season. Therefore, the gradient must be calculated as part of the stage-discharge calculation used in MGSFlood for the continuous hydrograph method. For designs using the single-event hydrograph, it is sufficiently accurate to calculate the hydraulic gradient based on one-half the maximum depth of water in the pond.

For the underlying soils of a CAVFS, use Equation 4-16 (pond gradient equation) to determine the hydraulic gradient if the CAVFS length is less than 30 times the width. A correction factor is not needed for CAVFS design. The designer can assume $CF_{size} = 1.0$ for CAVFS design. If the CAVFS length is greater than or equal to 30 times the width, use Equation 4-22 (trench gradient equation) to determine the hydraulic gradient for the underlying soils of a CAVFS. No correction factors for biofouling or siltation are needed for underlying soils of CAVFS since those soils are under the CAVFS layer.

9. **Calculate the infiltration rate using Darcy's Law as follows:**

$$f = 0.5K_{equiv} \left(\frac{dh}{dz} \right) = 0.5K_{equiv} (i) \quad (4-18)$$

- where: f = the infiltration rate of water through a unit cross section of the infiltration facility (in/hr)
 K_{equiv} = the average saturated hydraulic conductivity (ft/day)
 dh/dz = the steady state hydraulic gradient
 i = the steady state hydraulic gradient
 0.5 = converts ft/day to in/hr

10. **Adjust the infiltration rate or infiltration stage-discharge relationship obtained in Steps 8 and 9.**

This is done to account for reductions in the rate resulting from long-term siltation and biofouling, taking into consideration the degree of long-term maintenance and performance monitoring anticipated; the degree of influent control (such as presettling ponds or biofiltration swales); and the potential for (among others) siltation, litterfall, or moss buildup based on the surrounding environment. It should be assumed that an average-to-high degree of maintenance will be performed on these facilities. A low degree of maintenance should be considered only when there is no other option (such as with access problems). The infiltration rates estimated in Steps 8 and 9 are multiplied by the reduction factors summarized in Table 4-7.

Table 4-7. Infiltration rate reduction factors to account for biofouling and siltation effects for ponds (Massmann, 2003).

Potential for Biofouling	Degree of Long-Term Maintenance/Performance Monitoring	Infiltration Rate Reduction Factor, $CF_{silt/bio}$
Low	Average to High	0.9
Low	Low	0.6
High	Average to High	0.5
High	Low	0.2

The values in this table assume that final excavation of the facility to the finished grade is deferred until all disturbed areas in the upgradient drainage area have been stabilized or protected (for example, construction runoff is not allowed into the facility after final excavation of the facility) as required in Section 5-4.2.1.

An example of a situation with a high potential for biofouling would be a pond located in a shady area where moss and litterfall from adjacent vegetation can build up on the pond bottom and sides, the upgradient drainage area will remain in a long-term disturbed condition, and no pretreatment (such as presettling ponds or biofiltration swales) is provided. Situations with a low degree of long-term maintenance include locations where access to the facility for maintenance is very difficult or limited or where there is minimal control of the party responsible for enforcing the required maintenance. A low degree of maintenance should be considered only when there is no other option.

Adjust this infiltration rate for the effect of pond aspect ratio by multiplying the infiltration rate determined in Step 9 (Equation 4-18) by the aspect ratio correction factor CF_{aspect} , as shown in the following equation. In no case shall CF_{aspect} be greater than 1.4.

$$CF_{aspect} = 0.02A_r + 0.98 \quad (4-19)$$

where: CF_{aspect} = the aspect ratio correction factor
 A_r = the aspect ratio for the pond (length/width)

The final infiltration rate will therefore be as follows:

$$f = (0.5K_{equiv})(i)(CF_{aspect})(CF_{silt/bio}) \quad (4-20)$$

The infiltration rates calculated based on Equations 4-18 and 4-20 are long-term design rates. No additional reduction factor or factor of safety is needed.

11. Determine the infiltration flow rate Q .

If the infiltration facility is located in eastern Washington, determine the infiltration flow rate Q using the Infiltration Pond Design Spreadsheet at: www.wsdot.wa.gov/Design/Hydraulics/Training.htm. If located in western Washington, determine the infiltration flow rate Q using MGSFlood.

12. Size the facility.

Size the facility to ensure the pond depths are between 2 and 6 feet, with 1-foot-minimum required freeboard. Use one of the following two approaches, depending on the type of hydrograph used:

- If using a continuous hydrograph for runoff treatment design, refer to Appendix 4A for a “Time-to-Drain” spreadsheet web link.

- If using a single-event hydrograph, calculate T_{req} using StormShed to determine the time it takes the pond to empty or from the value of Q determined from Step 11 and V_{design} from Step 2, as follows:

$$T_{req} = \frac{V_{design}}{Q} \quad (4-21)$$

where: T_{req} = the time required to infiltrate the design stormwater volume

V_{design} = volume of stormwater in cubic feet

Q = infiltration flow rate in cfs

This value of T_{req} must be less than or equal to the maximum allowed infiltration time specified in the Site Suitability Criteria in Section 4-5.1.

13. **Construct the facility.**

Maintain and monitor the facility for performance in accordance with the *Maintenance Manual*.

4-5.3.2 Simplified Approach to Determining Infiltration Rates

The Simplified Approach was derived from high groundwater and shallow pond sites in western Washington and, in general, will produce conservative designs. Applying this method to eastern Washington will produce even more conservative designs. The Simplified Approach can be used when determining the trial geometry of the infiltration facility for small or low-impact facilities or for facilities where a more conservative design is acceptable. The simplified method must not be used for determining short-term soil infiltration rates for runoff treatment infiltration facilities in western Washington, as referenced in SSC 5. The Simplified Approach is applicable to ponds, vaults, and trenches and includes the following steps (see Figure 4-16 for a flowchart of this process):

1. **Select a location.**

This will be based on the ability to convey flow to the location and the expected soil conditions of the location. The minimum setback distances must also be met.

2. **Estimate volume of stormwater, V_{design} .**

For eastern Washington, a single-event hydrograph for the volume can be used, allowing for a simplified modeling approach such as StormShed. For western Washington, a continuous hydrograph should be used, requiring MGSFlood for the calculations.

3. **Develop trial infiltration facility geometry.**

To accomplish this, assume an infiltration rate based on previously available data, or a default infiltration rate of 0.5 inches/hour can be used. This trial

facility geometry should be used to help locate the facility and for planning purposes in developing the geotechnical subsurface investigation plan.

4. **Conduct a geotechnical investigation.**

The geotechnical investigation evaluates the suitability of the site for infiltration; establishes the infiltration rate for design; and evaluates slope stability, foundation capacity, and other geotechnical design information needed to design and assess constructibility of the facility. The geotechnical investigation is described in Section 4-5.3.1, Steps 4 and 5 (Figures 4-14 and 4-15).

5. **Determine the infiltration rate.**

Ecology's SMMWW provides a correlation between the D_{10} size of the soils **below the infiltration facility and the infiltration rate, as shown in Table 4-8**, which can be used to estimate the infiltration rate.

The data that form the basis for Table 4-8 were from soils that would be classified as sands or sandy gravels. No data were available for finer soils at the time the table was developed. However, additional data based on recent research (Massmann et al., 2003) for these finer soils are now available and are shown in Figure 4-17.

Figure 4-17 provides a plot of this relationship between the infiltration rate and the D_{10} of the soil, showing the empirical data upon which it is based. The figure provides an upper and lower bound range for this relationship, based on the empirical data. These upper and lower bound ranges can be used to adjust the design infiltration rate to account for site-specific issues and conditions.

The long-term rates provided in Table 4-8 represent average conditions regarding site variability, the degree of long-term maintenance, and pretreatment for TSS control. They also represent a moderate depth to groundwater below the pond.

Table 4-8. Recommended infiltration rates based on ASTM Gradation Testing.

D_{10} Size from ASTM D422 Soil Gradation Test (mm)	Estimated Long-Term (Design) Infiltration Rate (inch/hour)
≥ 0.4	9
0.3	6.5
0.2	3.5
0.1	2.0
0.05	0.8

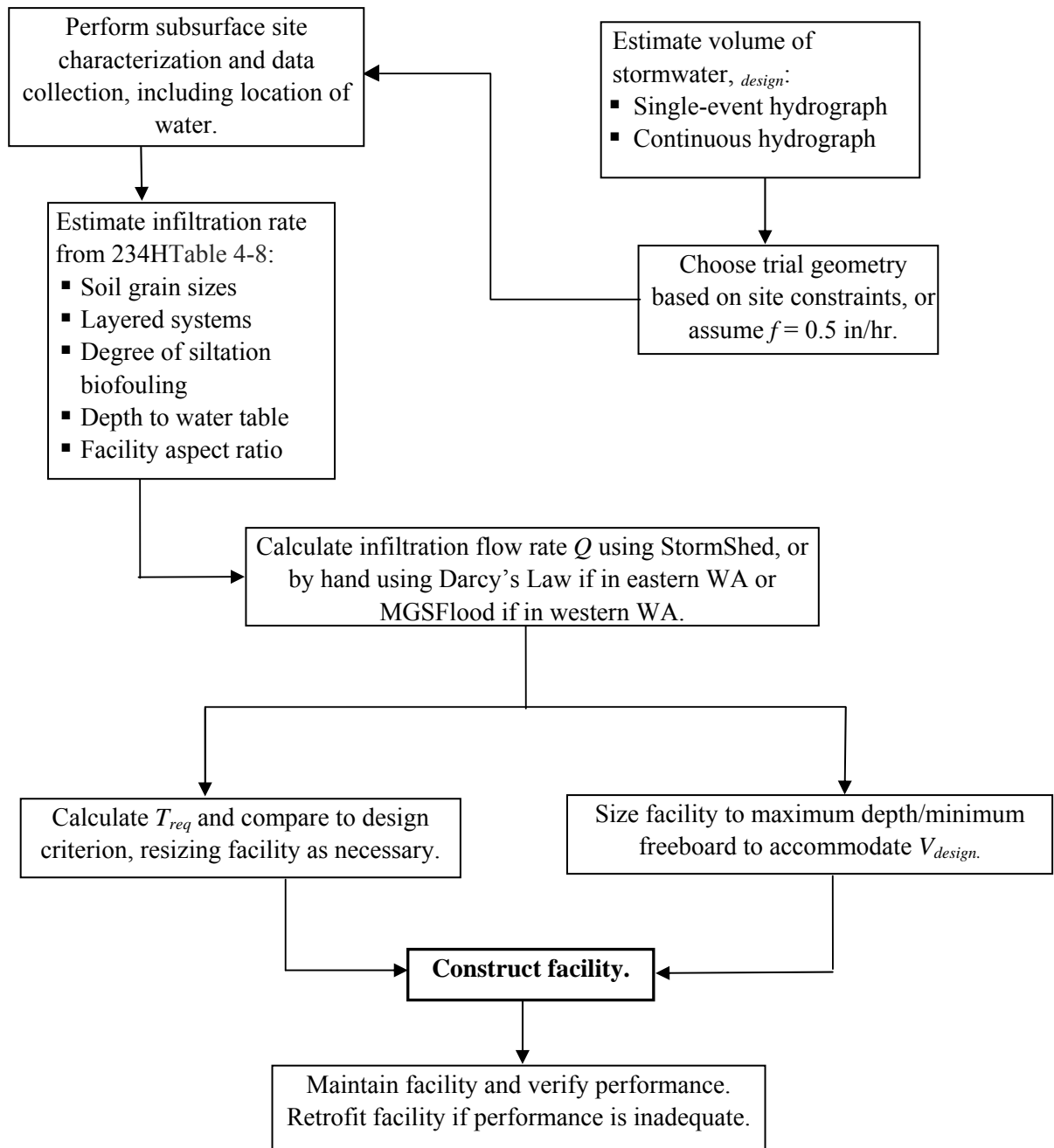

(Note: Use for trial geometry, small or low-impact facilities, or for facilities where a more conservative design is acceptable.)

Figure 4-16. Engineering design steps for design of infiltration facilities: Simplified infiltration rate procedure.

The long-term infiltration rates in Table 4-8 may need to be decreased (toward the lower bound in Figure 4-17) if the site is highly variable; the groundwater table is shallow; there is fine layering present that would not be captured by the soil gradation testing; or maintenance and influent characteristics are not well controlled. However, if influent control is good (for example, water entering the pond is pretreated through a biofiltration swale or presettling basin); if a good, long-term maintenance plan will be implemented; and if the water table is moderate in depth, then an infiltration rate toward the upper bound in the figure could be used.

The infiltration rates provided in Figure 4-17 represent rates for homogeneous soil conditions. If more than one soil unit is located within 2.5 times the maximum design depth of water proposed for the infiltration facility, or at least 2 feet into the saturated zone but no less than 6 feet below the base of the infiltration facility, use the lowest infiltration rate determined from each of the soil units as the representative site infiltration rate.

The rates shown in Table 4-8 and Figure 4-17 are long-term design rates. No additional reduction factor or factor of safety is needed.

Note that Table 4-8 provides an infiltration rate, not a saturated hydraulic conductivity that must be multiplied by a hydraulic gradient or other factors, as provided in Equation 4-20. The infiltration rates provided in this table assume a fully developed groundwater mound and very low hydraulic gradients. Hence, if the water table is relatively deep, the infiltration rate calculated from Equation 4-20 will likely be more accurate, but less conservative, than the infiltration rates provided in Table 4-8. For shallow water table situations, Equation 4-20 will produce infiltration rates similar to those provided in Table 4-8 and shown in Figure 4-17.

The minimum infiltration rate at which infiltration would be considered the primary function of the facility is 0.5 inches/hour. Infiltration can still be taken into account if the infiltration rate is lower, but it should be considered a secondary design parameter for the facility.

6. **Determine the infiltration flow rate Q .**

If the infiltration facility is located in eastern Washington, determine the infiltration flow rate Q using the Infiltration Pond Design Spreadsheet at:
www.wsdot.wa.gov/Design/Hydraulics/Training.htm

If the infiltration facility is located in western Washington, determine the infiltration flow rate Q using MGSFlood.

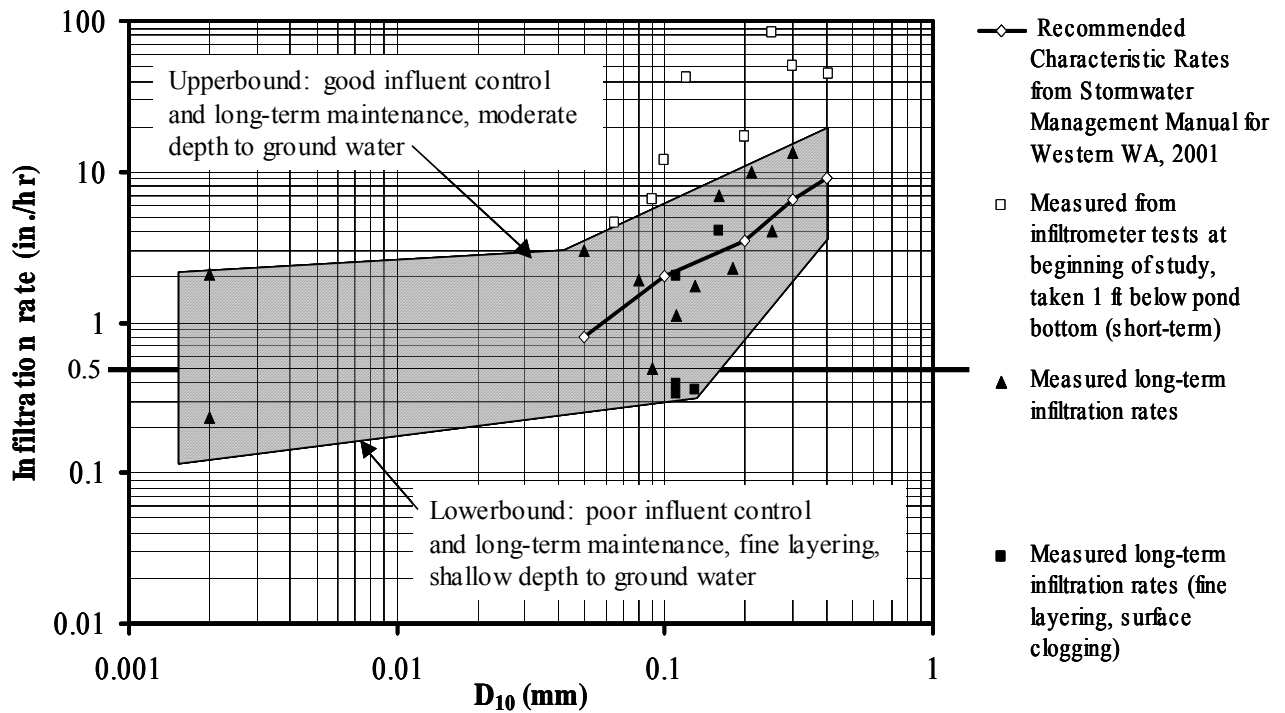

(Note: The mean values represent low-gradient conditions and relatively shallow ponds.)

Figure 4-17. Infiltration rate as a function of the D_{10} size of the soil for ponds in western Washington.

7. Size the facility.

Size the facility to ensure the pond depths are between 2 and 6 feet, with 1-foot-minimum required freeboard. Use one of the following two approaches, depending on the type of hydrograph used:

- If using a continuous hydrograph for runoff treatment design, refer to Appendix 4A for a “Time-to-Drain” spreadsheet web link.
- If using a single-event hydrograph, calculate T_{req} using Equation 4-21 from the Detailed Approach in Section 4-5.3.1, using the value of Q determined from Step 11 and V_{design} from Step 2 of that approach. The value of T_{req} calculated must be less than or equal to the maximum allowed infiltration time specified in the Site Suitability Criteria in Section 4-5.1.

8. Construct the facility.

Maintain and monitor the facility for performance in accordance with the *Maintenance Manual*.

4-5.3.3 Determining Infiltration Rates for Soil Amendment BMPs

It is necessary to establish the long-term infiltration rate of an amended soil or engineered soil mix when used as a BMP design component to achieve treatment or flow control requirements. These guidelines are applicable to CAVFS and engineered dispersion. The assumed design infiltration rate should be the lower of the following two rates: (1) the estimated long-term rate of the engineered soil mix (see Figure 4-18), or (2) the initial (short-term or measured) infiltration rate of the underlying soil profile. The underlying native soil can be tested using either the Detailed Approach in Section 4-5.3.1 or the Simplified Approach in Section 4-5.3.2.

Use the long-term infiltration rate of the engineered soil mix as the assumed infiltration rate of the overlying soil mix if it is lower than the underlying native soil. If the underlying native soil is lower than the engineered soil mix, use either the underlying native soil infiltration rate or a varied infiltration rate that includes both the engineered soil mix infiltration rate and the native soil infiltration according to Section 4-5.3.1, Step 6. Also, refer to Table 4-4 for flow control modeling guidelines to determine flow reduction benefits using MGSFlood.

Soil Specification

Proper soil specification, preparation, and installation are the most critical factors for LID BMP performance. Soil specifications can vary according to the design objectives and the in situ soil. For more information, see Section 5-4.3.2.

4-5.3.3.1 Design Procedure for Compost-Amended Vegetated Filter Strips (CAVFS) for Western Washington

The design for CAVFS is an iterative process in MGSFlood to adequately address the infiltrative capacity of both the compost amended layer and the underlying soils to achieve the 91% volume treatment criteria.

Flow through CAVFS is simulated using Darcy's Equation (as shown in Figure 4-19), where K_c is the saturated hydraulic conductivity. Note that the width dimension corresponds to the CAVFS width along the slope. Infiltration is accounted for using a constant infiltration rate into the underlying soils. During large storms, the voids in the CAVFS may become full (the CAVFS is saturated) in which case runoff is simulated as overflow down the surface of the CAVFS. The runoff volume filtered by the CAVFS, the volume infiltrated, and the volume flowing over the CAVFS surface are listed in the project report.

Precipitation and evapotranspiration may (optionally) be applied to the CAVFS. If precipitation and evapotranspiration are applied in the CAVFS link, do not include the area of the CAVFS in the Subbasin Area input.

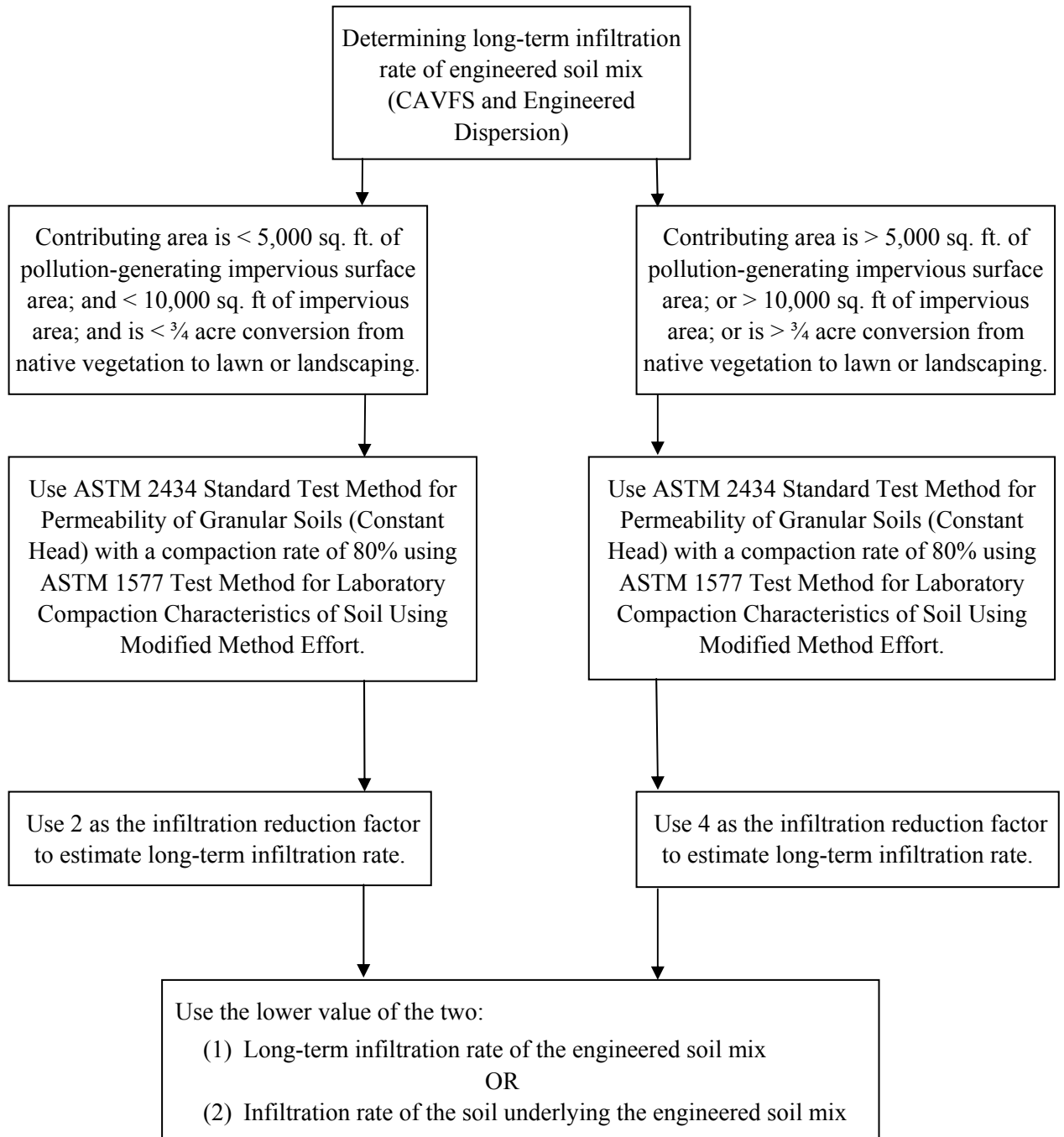

Figure 4-18. Determining infiltration rate of soil amendments.

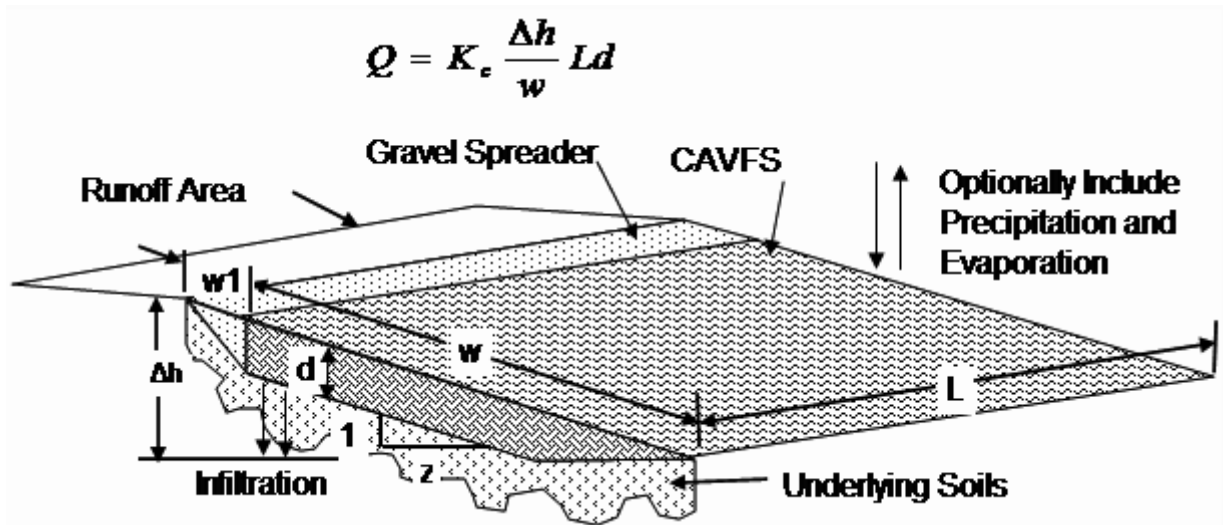

Figure 4-19 CAVFS Detail.

1. **Follow Steps 1 through 11 in the Detailed Approach for Determining Infiltration Rates for the underlying soils of a CAVFS (see Section 4-5.3.1).**
2. **Follow Section 4-5.3.3 for CAVFS hydraulic conductivity.**
 - Note: The ASTM method described in Section 4-5.3.3 provides an infiltration rate. Assuming a hydraulic gradient of one, the infiltration rate is the same as the hydraulic conductivity.
3. **Modeling steps for CAVFS.**

Using MGSFlood, the dimensions of the CAVFS will be set as follows under the Network Tab:

- Select the Link type: CAVFS

CAVFS Depth $d(ft)$: This is a constant depth of 1 foot for all CAVFS designs unless other recommendations have been given based on the organic content percentage by the HQ Roadside and Site Development Section.

CAVFS Porosity (% by Volume): The default value is 20%, but must be verified or reestablished by the WSDOT Materials Lab or a licensed geotechnical engineer for the particular site and particular installation.

CAVFS Hydraulic Conductivity (ft/day): The default value is 2 ft/day and must be verified or reestablished by the WSDOT Materials Lab or a licensed geotechnical engineer for the particular site and particular installation.

CAVFS Length (ft): The length parallel to the roadway.

CAVFS Width (ft): The width perpendicular to the roadway. This is usually the parameter being solved for.

Underlying Soil Infiltration Rate: Refer to Step 1.

CAVFS Slope Z: The horizontal slope of the roadway embankment—it cannot be steeper than 4:1.

Gravel Spreader Width (ft): The width perpendicular to the roadway.

Gravel Porosity (% by Volume): Typical value for gravel porosity is 30.

Gravel Hydraulic Conductivity (ft/day): The default value is 4 ft/day and must be verified or reestablished by the WSDOT Materials Lab or a licensed geotechnical engineer for the particular site and particular installation.

4. **Determine that the volume of runoff infiltrated and filtered is 91% or greater than the total runoff volume.**

MGSFlood will output Postdeveloped CAVFS Treatment Statistics in the MGSFlood Project Report file. The report file will give the percent treated for the structure defined in Step 3. The designer should verify that this number is equal to or greater than 91%.

5. **Flow Control Compliance.**

After a successful runoff treatment design (Steps 1–4 above), the designer may be able to widen the CAVFS to try to meet the flow duration standard if the particular TDA is required to provide flow control. Otherwise, a flow control structure should be linked downstream of the CAVFS to attenuate the resultant runoff and meet the flow duration standard. Contact the Region Hydraulics Office for questions regarding flow control modeling. For an example problem, refer to Appendix 4A.

4-5.4 Underground Injection Facilities

Infiltration is one of the preferred methods for disposing of excess stormwater in order to preserve natural drainage systems in Washington. Subsurface infiltration is regulated by the Underground Injection Control (UIC) Rule, which is intended to protect underground sources of drinking water (www.ecy.wa.gov/programs/wq/grndwtr/uic/index.html). By definition, a UIC facility includes a constructed subsurface fluid distribution system or a dug hole that is deeper than the largest surface dimension. For the purposes of this section, infiltration systems include drywells (BMP IN.05) and infiltration trenches with perforated underdrain pipes (BMP IN.03) designed to discharge stormwater directly into the ground. The following are not regulated as stormwater underground injection facilities:

- Infiltration trenches that do not include perforated underdrain pipes
- Infiltration vaults (BMP IN.04)

- Buried pipe and/or tile networks that serve to collect water and discharge that water to a conveyance system or a surface water
- Any facilities that are designed to receive fluids other than stormwater

For additional guidance and design criteria for protection of groundwater see “Guidance for UIC Wells that Manage Stormwater Activities” published by Ecology:

www.ecy.wa.gov/programs/wq/grndwtr/uic/index.html

Vadose zones, the area between the bottom of a facility and the top of the groundwater table, vary widely in their ability to remove stormwater pollutants based on their thickness and soil texture. This section provides instructions on how to identify the conditions under which the vadose zone may be presumed to provide sufficient treatment for a given pollutant loading surface. This section also identifies the types of pretreatment that are required to meet Minimum Requirement 5 when the vadose zone alone cannot be presumed to adequately treat runoff. Following the requirements of this section will ensure a facility meets the nonendangerment standards in the UIC Rule and Minimum Requirement 5, Runoff Treatment (see Section 3-3.5), under the *presumptive approach*. The demonstrative approach in Section 1-1.3 may be used if WSDOT can document that alternative methods will protect water quality. Data requirements for using the *demonstrative approach* in association with underground injection facilities are also described in Ecology’s “Guidance for UIC Wells that Manage Stormwater Activities” (see website above).

All new underground injection facilities must meet the requirements of this section under the presumptive approach. If an existing facility is within the limits of an improvement project, it shall be brought into compliance with the requirements or replaced with a different BMP type unless an Engineering and Economic Feasibility (see Section 2-7.4) assessment shows it is not feasible. No additional flows shall be allowed to enter existing underground injection facilities that do not meet the requirements of this section.

Registering Underground Injection (UIC) Facilities

The UIC Rule requires WSDOT to assess and register all underground injection facilities. Region Hydraulics offices are primarily responsible for the registration and assessment of existing facilities. Contact the appropriate office whenever existing facilities are encountered in the field to determine whether they have already been registered and assessed. If any UIC facilities (such as drywells and infiltration trenches with perforated underdrain pipes) within the limits of a project have not been registered, the Project Engineer’s Office, in coordination with the Region Hydraulics Office, shall complete the registration and assessment forms.

Coordinate with the Region Hydraulics Office for technical support when collecting data to register proposed underground injection control facilities and to establish pretreatment requirements. Information that must be collected includes physical location, pollutant-generating properties of the drainage area, and the depth and texture of vadose zone soils.

Physical location information, including latitude, longitude, and state route, must be collected in accordance with the Roadside Features Inventory Program's *Field Procedures Manual*. This manual contains specific instructions regarding drywells and vaults, but not infiltration trenches; however, infiltration trenches must be inventoried in the same manner described for drywells using the manhole lid or other identifiable surface feature as the point from which to identify its location. Observe the surrounding landscape characteristics like topography and presence of nearby water bodies when performing field work. Such observations can help confirm the accuracy of geotechnical data about the depth of the vadose zone.

Download the Underground Injection Control Registration Spreadsheet at the HQ Environmental Services Office (ESO), Stormwater & Watersheds Program's website:

☞ www.wsdot.wa.gov/Environment/WaterQuality/#facilities. Provide information for each well as shown on the *Example* row of the Excel file. The Region Hydraulics Office is the primary resource if assistance is needed to complete the spreadsheet. E-mail the completed table to the Region Hydraulics Office and the HQ ESO Stormwater & Watersheds Program. Submitted spreadsheet information will be forwarded to Ecology; project offices do not need to directly register the UIC facilities. The UIC registration information should also be included in the design justification section of the Hydraulic Report. Contact the Water Quality Team Leader (360-570-6648) at the HQ ESO Stormwater & Watersheds Program for questions about UIC registration.

Establishing Treatment Capacity Class

Vadose zone properties must be characterized to establish the treatment capacity class of the vadose zone using Table 4-9. Existing WSDOT data may provide sufficient information about the depth to groundwater and the vadose zone soil texture. UIC wells shall not directly discharge into groundwater. The minimum vertical separation is 5 feet between the bottom of the UIC well and the seasonal high water table. If the minimum separation can not be met the demonstrative approach may be used for rule authorization. (See the "Guidance for UIC Wells That Manage Stormwater" document from Ecology for additional information on minimum separation and the demonstrative approach.) Contact the Regional Materials Engineer (RME) for assistance locating and evaluating WSDOT's geotechnical data in the vicinity of the proposed facility. If WSDOT does not have data regarding depth to groundwater and vadose zone soil texture, the following sources should be considered:

- Washington State Department of Ecology drinking well log database containing water table levels: ☞ apps.ecy.wa.gov/welllog/index.asp
- Washington State Department of Health Source Water Assessment Program: ☞ www.doh.wa.gov/ehp/dw/our_main_pages/swap.htm
- USGS groundwater reports: ☞ wa.water.usgs.gov/pubs/
- Local health departments
- Local municipalities

The RME may consider the available data to be adequate for establishing vadose zone treatment capacity class. If not, vadose zone soils will have to be tested. (See Step 4 in Section 4-5.3.1 for geotechnical testing requirements.)

Use Table 4-9 to determine the level of treatment that will be provided by the underground injection facility given the thickness and texture of vadose zone materials.

Table 4-9. Treatment capacity class based on vadose zone properties.

Treatment Capacity Class and Minimum Thickness*	Description of Vadose Zone Layer
<p style="text-align: center;">HIGH Minimum thickness of <u>5 feet</u></p>	<ul style="list-style-type: none"> ▪ Average grain size <0.125mm ▪ Sand to silt/clay ratio of 1:1 and sand plus gravel < than 50% ▪ Lean, fat, or elastic clay ▪ Sandy or silty clay ▪ Silt ▪ Clayey or sandy silt ▪ Sandy loam or loamy sand ▪ Silt/clay with interbedded sand ▪ Well-compacted, poorly sorted materials ▪ Includes till, hardpan, caliche, and loess
<p style="text-align: center;">MEDIUM Minimum thickness of <u>10 feet</u></p>	<ul style="list-style-type: none"> ▪ Average grain size 0.125mm to 4mm ▪ Sand to silt/clay ratio <u>from</u> 1:1 to 9:1 and percent sand > percent gravel ▪ Fine, medium, or coarse sand ▪ Sand with interbedded clay and/or silt ▪ Poorly compacted, poorly sorted materials ▪ Includes <u>some alluvium and outwash deposits</u>
<p style="text-align: center;">LOW Minimum thickness of <u>25 feet</u></p>	<ul style="list-style-type: none"> ▪ Average grain size 4mm to 64mm ▪ Sand to silt/clay ratio > 9:1 and percent sand < percent gravel ▪ <u>Sandy gravel, gravelly sand, or sand and gravel</u> ▪ <u>Poorly-sorted, silty, or muddy gravel</u> ▪ Includes some alluvium and outwash deposits
<p style="text-align: center;">NONE <u>Minimum thickness not applicable</u></p>	<ul style="list-style-type: none"> ▪ Average grain size > 64mm ▪ Total fines (sand and mud) < 5% ▪ <u>Well-sorted or clean gravel</u> ▪ Boulders and/or cobbles ▪ Fractured rock ▪ Includes fractured basalt, other fractured bedrock, and cavernous limestone

* Assume NONE for treatment class if minimum thickness is not met.

Determine Pollutant Loading Class

Runoff is categorized into pollutant loading classes based on ADT. Criteria for establishing pollutant loading classes are included in Table 4-10. ADT data are available in WSDOT's Annual Traffic Reports at: www.wsdot.wa.gov/mapsdata/tdo/annualtrafficreport.htm. The GIS Workbench also contains a data layer showing where the different ADT thresholds are met. The Traffic Data Office must be contacted for intersection ADT data. Parking area use levels and their relationship to building size are not tracked by WSDOT. Contact maintenance staff for an estimate of parking area use levels at maintenance and park-and-rides facilities.

Table 4-10. Stormwater pollutant loading classifications for UIC facilities receiving stormwater runoff.

Pollutant Loading Classification	Proposed Land Use or Site Characteristics*
INSIGNIFICANT	<ul style="list-style-type: none"> ▪ Impervious surfaces not subject to motorized vehicle traffic, <u>deicing</u> sand, or deicing compounds ▪ Unmaintained open space
LOW	<ul style="list-style-type: none"> ▪ Parking areas with < 40 trip ends* per 1,000 s.f. of gross building area or < 100 trip ends ▪ Highways Inside Urban Growth Management Areas (UGMA) <ul style="list-style-type: none"> □ <u>Fully or partially controlled limited access highways with < 15,000 ADT*</u> □ <u>Other highways with < 7,500 ADT</u> ▪ Highways Outside UGMA <ul style="list-style-type: none"> □ <u>All highways with < 15,000 ADT</u>
MEDIUM	<ul style="list-style-type: none"> ▪ Parking areas with 40–100 trip ends per 1,000 s.f. of gross building area or 100–300 total trip ends ▪ Intersections controlled by traffic signals <u>where the main highway is not > 25,000 ADT and there is not > 15,000 ADT on the intersecting highway</u> ▪ Transit center bus stops ▪ Highways Inside UGMA <ul style="list-style-type: none"> □ <u>Fully or partially controlled limited access highways between 15,000 and 30,000 ADT</u> □ <u>Other highways with 7,500–30,000 ADT</u> ▪ Highways Outside of UGMA <ul style="list-style-type: none"> □ <u>All highways between 15,000 and 30,000 ADT</u>
HIGH	<ul style="list-style-type: none"> ▪ <u>Eastern Washington highways with > 30,000 ADT</u> ▪ <u>Intersections controlled by traffic signals where the main highway has > 25,000 ADT and the intersecting highway has > 15,000 ADT</u> ▪ Parking areas with > 100 trip ends per 1,000 s.f. of gross building area or > 300 total trip ends ▪ Highway rest areas

* Average daily traffic (ADT) count and trip ends must be calculated for an assumed 20-year project design life. Contact the Traffic Data Office, Travel Analysis Branch, for assistance: www.wsdot.wa.gov/mapsdata/tdo/travelanalysis.htm

Determine Treatment Requirements

Use Table 4-11 to determine the required level of treatment based on the treatment capacity and pollutant loading classes associated with each facility. All new facilities must provide the appropriate level of treatment as defined in Table 4-11.

Table 4-11. Matrix for determining pretreatment requirements.

Treatment Capacity \ Pollutant Loading	HIGH	MEDIUM	LOW	NONE
INSIGNIFICANT	None	None	None	None
LOW	None	None	None	Basic treatment ²
MEDIUM	Two-stage drywell ¹	Two-stage drywell ¹	Basic treatment	Basic treatment
HIGH	Oil control ³	Oil control ³	Basic treatment and oil control ³	Basic treatment and oil control ³

¹ A two-stage drywell includes a catch basin or spill control structure that traps small quantities of oils and solids; the spill control device may be a turned-down pipe elbow or other passive device. This pretreatment requirement applies to all UIC facilities, not just drywells. Catch basins or other presettling spill control devices must be inspected and cleaned regularly.

² For low-pollutant loading sites, implementation of appropriate source control BMPs may be employed in lieu of structural treatment BMPs.

³ At high-density intersections and at commercial or industrial sites subject to an expected average daily traffic count (ADT) of 100 vehicles/1000 ft² gross building area, sufficient quantities of oil will be generated to justify operation of a separator BMP.

At other high-use sites, designers may select a basic runoff treatment BMP that also provides adsorptive capacity, such as a biofiltration swale, bioinfiltration pond, a filter strip, or a compost-amended vegetated filter strip (CAVFS), or other adsorptive technology, in lieu of a separator BMP.

The requirement to remove oil for all highways with ADT > 30,000 applies only in eastern Washington. For those highways in eastern Washington, an oil control facility is not required; instead a basic treatment facility with adsorptive characteristics (listed above) is required.

This requirement to apply a basic treatment facility with adsorptive characteristics also applies to commercial parking and to highways with ADT > 7500; alternatively a simple passive oil control device such as a turned-down elbow may be used.

To preserve infiltration rates and provide some solid removal and spill protection, all UIC facilities should be preceded by a catch basin with a turned-down elbow or tee and/or a pre-settling basin. Presettling basins should be as large as site constraints allow. They do not have to meet the requirements of BMP RT.24, but should provide 4–6 inches of storage prior to overflow into the UIC facility.

Existing underground injection facilities that meet the treatment requirements in Table 4-11 are presumed to provide adequate groundwater protection. Existing wells that do not meet the treatment requirements in Table 4-11 are considered deficient. The treatment requirements in Table 4-11 identify the retrofit requirements for deficient facilities.

Application and Limitations

For UIC facilities, an evaluation of the infiltration capacity is necessary to determine whether the facility will be able to accommodate the necessary volume of water. Infiltration rates

lessen over time due to clogging, so the long-term infiltration rate under the worst-case scenario should be accommodated by the design. The amount of time it takes for water to drain out of a UIC facility depends on how fast the soil allows water to infiltrate and how much water the UIC facility holds. For eastern Washington, facilities are designed to completely drain ponded runoff from the flow control design storm within 48 to 72 hours after flow to the UIC facility has stopped.

Siting Criteria and Treatment Requirements

Prior to evaluating runoff treatment considerations, the designer should be certain that the site meets the criteria for infiltration found in Chapters 4 and 5 and the requirements of this section.

▪ Subsurface Geologic Data

Geologic information may be available from regional subsurface geology maps in publications from the Department of Natural Resources (DNR) or the U.S. Geological Survey; from a well borehole log(s) in the same quarter section on Ecology's web site; or from local governments. Surface soils maps generally do *not* provide adequate information, although the parent material information provided may be helpful in some locations. Well borehole log locations should be verified because electronic databases contain many errors of this type.

When using borehole logs, a "nearby" site is generally within ¼ mile. Subsurface geology can vary considerably in a very short horizontal distance in many areas of the state, so professional judgment should be used to determine whether the available data are adequate or site exploration is necessary.

Where reliable regional information or nearby borehole logs are not readily available, it will be necessary to obtain data through site exploration. Alternatively, for small projects where site exploration is not cost-effective, a design professional might apply a conservative design approach, subject to the approval of region or HQ hydraulics staff and/or the WSDOT Materials Lab.

For treatment capacity and pollutant loading definitions, see Tables 4-9 and 4-10. All project proponents should read Section 4-5.1 for exceptions or other requirements that apply in certain situations. Appropriate pretreatment and presettling requirements must be determined using the information provided in Chapter 5, BMP Selection Process.

4-5.4.1 Design Procedure for Infiltration Trenches

The Detailed Approach for infiltration trenches was obtained from Massmann (2003) and is applicable for trenches with flat or shallow slopes—not to be used for slopes greater than 0.5%. Procedures for the Detailed Approach for both sheet flow and end of pipe applications are as follows:

1. **Follow Steps 1 through 7 in the Detailed Approach (see Section 4-5.3.1).**
2. **Calculate the hydraulic gradient.**

If using a single-event hydrograph or continuous hydrograph, calculate the hydraulic gradient for trenches as follows:

$$gradient = i_t \approx \frac{D_{wt} + D_{trench}}{78(K_{equiv}^{0.05})} \quad (4-22)$$

where: i_t = steady state hydraulic gradient in the trench
 D_{wt} = the depth from the base of the infiltration facility to the water table, in feet
 K_{equiv} = the average saturated hydraulic conductivity, in feet/day
 D_{trench} = the depth of water in the trench, in feet

As is true of Equation 4-16, Equation 4-22 is applicable to conditions where a full groundwater mound develops.

If the calculated gradient is greater than 1.0, the water table is considered to be deep and a maximum gradient of 1.0 must be used. It is sufficiently accurate to calculate the hydraulic gradient assuming that D_{trench} is equal to one-half the trench depth.

3. **Follow Step 9 in the Detailed Approach (see Section 4-5.3.1).**
4. **Adjust the infiltration rate or infiltration stage-discharge relationship obtained in Step 9.**

This accounts for reductions in the rate resulting from long-term siltation and biofouling, taking into consideration the degree of long-term maintenance and performance monitoring anticipated; the degree of influent control (such as presettling ponds or biofiltration swales); and the potential for siltation and bio-buildup based on the surrounding environment. It should be assumed that an average-to-high degree of maintenance will be performed on these facilities. A low degree of maintenance should be considered only when there is no other option (such as with access problems). The infiltration rate estimated in Step 9 is multiplied by the reduction factors summarized in Table 4-12. The final infiltration rate is therefore as follows:

$$f = (0.5K_{equiv})(i_t)(CF_{silt/bio}) \quad (4-23)$$

The infiltration rates, which were calculated based on Equation 4-23, are long-term design rates. No additional reduction factor or factor of safety is needed.

Table 4-12. Infiltration rate reduction factors to account for biofouling and siltation effects for trenches (Massmann, 2003).

Potential for Biofouling	Degree of Long-Term Maintenance/Performance Monitoring	Infiltration Rate Reduction Factor, $CF_{silt/bio}$
Low	Average to High	0.9
Low	Low	0.8
High	Average to High	0.75
High	Low	0.6

Although siltation and biofouling may be less prevalent in infiltration trenches than in infiltration ponds, field data have not been collected that would allow correction factors to be estimated for trenches. However, the computer simulation results described in Massmann et al. (2003) suggest that reductions in saturated hydraulic conductivity due to bottom clogging from siltation and biofouling may have relatively small effects on overall infiltration rates and gradients for trenches. This is because of the larger amounts of lateral flow that occur in trenches compared to ponds. Reductions in vertical flow from the bottom of the trench are offset by increases in lateral flow, particularly for trenches with deeper water levels.

5. **Follow Steps 11 through 13 in the Detailed Approach (see Section 4-5.3.1).**

4-5.4.2 Design Procedure for Drywells

This design procedure was obtained from a research project conducted by Massmann (2004) and developed for eastern Washington. The design procedure for drywells originated from a design based on soil types prevalent in Spokane County. This research helped to determine a more accurate drywell design based on soils typically found throughout eastern Washington and deep groundwater tables. Steps for this procedure are as follows:

1. **Estimate volume of stormwater, V_{design} .**
For eastern Washington, a single-event hydrograph or value for the volume can be used, allowing a modeling approach such as StormShed to be conducted. For western Washington, a continuous hydrograph generally should be used, requiring a model such as MGSFlood to perform the calculations. (See Section 4-3 for western Washington methodology and Section 4-4 for eastern Washington methodology.)
2. **Follow Steps 4 through 5 in the Detailed Approach (see Section 4-5.3.1).**
3. **Determine the average saturated hydraulic conductivity as noted in Section 4-5.2.1.**
4. **Estimate the uncorrected steady-state infiltration rate for drywells.**

The results of the computer simulations included in Massmann (2004) were used to develop regression equations relating steady-state flow rates with saturated hydraulic conductivity values and the depth to groundwater. The following two regression equations were derived from the results of these computer simulations:

$$\text{Double-barrel wells: } Q = K[3.55\ln(D_{wt}) + 12.32] \quad (4-24)$$

$$\text{Single-barrel wells: } Q = K[1.34\ln(D_{wt}) + 8.81] \quad (4-25)$$

where: Q = the infiltration rate in cfs

K = the average saturated hydraulic conductivity value in ft/minute

D_{wt} = the depth from the bottom of the drywell to groundwater in feet

Uncorrected steady-state infiltration rates for single- and double-barrel configurations can be estimated using the regression equations given in Equations 4-24 and 4-25.

5. **Apply correction factor for siltation.**

Siltation and plugging may reduce the equivalent saturated hydraulic conductivity values of the facilities by an order of magnitude or more. This will result in a corresponding reduction in infiltration rate. If pretreatment cannot be provided, the design infiltration rates calculated in Step 3 above should be reduced by a factor on the order of 0.5 or less.

6. **Size the facility.**

Because this design procedure was based on eastern Washington conditions, the facility sizing and drawdown time requirement for eastern Washington must be applied even if designing a drywell in western Washington. Until further research can be completed for drywell design in western Washington, the more conservative drawdown time of eastern Washington must be used.

Calculate T_{req} using Equation 4-21 from the Detailed Approach (see Section 4-5.3.1), using the value of Q determined from Step 11, and V_{design} from Step 1 above. The value of T_{req} calculated must be less than or equal to the maximum allowed infiltration time specified in the Site Suitability Criteria in Section 4-5.1.

7. **Construct the facility.**

Maintain and monitor the facility for performance in accordance with the *Maintenance Manual*.

4-6 Wetland Hydroperiods

An important consideration in the stewardship of certain wetland functions is the protection and control of a wetland's *hydroperiod*. The hydroperiod is the pattern of fluctuation of water depth and the frequency and duration of water levels on the site. This includes the duration and timing of drying in the summer. A hydrologic assessment is useful to measure or estimate elements of the hydroperiod under existing **preproject** and anticipated **postproject** conditions. This assessment involves reviewing and applying the best available science to assess potential impacts and deciding whether hydrological modeling is warranted.

Wetland hydroperiod analysis is of concern when proposing to discharge stormwater into or detract stormwater from a natural wetland (not constructed). The purpose of the analysis is to determine whether the stormwater will change the natural hydroperiod beyond the limits allowed. When this is an issue on a project, contact the region environmental staff for assistance. Refer to Minimum Requirement 7 (see Section 3-3.7.3) for the process, if applicable.

4-7 Closed Depression Analysis

Analysis of closed depressions requires careful assessment of the existing hydrologic performance in order to evaluate a proposed project's potential impacts. The applicable flow control requirements (see Minimum Requirement 6, Section 3-3.6) and the local government's Sensitive Areas Ordinance and Rules (if applicable) should be thoroughly reviewed prior to proceeding with the analysis. A calibrated continuous simulation hydrologic model must be used for closed depression analysis and design of mitigation facilities. Where an adequately calibrated continuous simulation model is not available, the procedures listed below can be followed.

4-7.1 Analysis and Design Criteria

The infiltration rates used in the analysis of closed depressions must be determined according to the procedures in Section 4-5. For closed depressions containing standing water, soil texture tests must be performed on dry land adjacent to, and on opposite sides of, the standing water (as practicable). The elevation of the testing surface at the bottom of the test pit must be 1 foot above the standing water elevation. A minimum of four tests must be performed to estimate an average surface infiltration rate.

Projects proposing to modify or compensate for replacement storage in a closed depression must meet the design criteria for detention ponds as described in Chapter 5.

4-7.2 Western Washington Method of Analysis

Closed depressions are analyzed using hydrographs routed as described in Section 4-5. Infiltration must be addressed where appropriate. In assessing the impacts of a proposed project on the performance of a closed depression, there are three cases that dictate different approaches to meeting Minimum Requirement 6 (see Section 3-3.6) and applicable local requirements. Note: Where there is a flooding potential, concern about rising groundwater levels, or local sensitive area ordinances and rules, this analysis may not be sufficient and local governments may require more stringent analysis.

Case 1

The 100-year recurrence interval storm runoff from an approved continuous simulation program, flowing from the TDA to the closed depression, is routed into the closed depression using only infiltration as outflow. If predevelopment runoff does not overflow the closed depression, then no runoff may leave the closed depression at the 100-year recurrence interval following development of a proposed project. This may be accomplished by excavating additional storage volume in the closed depression, subject to all applicable requirements (for example, providing a defined overflow system).

Case 2

The 100-year recurrence interval storm runoff from an approved continuous simulation program, from the TDA to the closed depression, is routed into the closed depression using only infiltration as outflow. If runoff overflows the closed depression under existing conditions during the 100-year recurrence interval storm, the performance objective can be met by excavating additional storage volume in the closed depression, subject to all applicable requirements (for example, providing a defined overflow system).

Case 3

The 100-year recurrence interval storm runoff from an approved continuous simulation program, from the TDA to the closed depression, is routed into the closed depression using only infiltration as outflow, and both cause overflow to occur. The closed depression must then be analyzed as a detention/infiltration pond. The required performance, therefore, is to meet the runoff duration standard specified in Minimum Requirement 6 (see Section 3-3.6), using an adequately calibrated continuous simulation model. This will require a control structure, emergency overflow spillway, access road, and other design criteria. Also, depending on who will maintain the system, it will require placing the closed depression in a tract dedicated to the responsible party.

4-7.3 Eastern Washington Methods of Analysis

The Stormwater Management Manual for Eastern Washington (SMMEW) states that local jurisdiction guidelines should be followed. The Spokane County Guidelines are included below. Other eastern Washington regions are encouraged to provide comment on their local guidelines and compare them to those stated below.

Depending upon soil characteristics, a closed depression may or may not accumulate surface water during periods of the year. Some closed depressions may be classified as wetlands. The design team must coordinate its stormwater design with consideration of any wetland area, as defined by applicable regulations that may govern wetland areas. If the proper authorities agree that none of these closed areas is a wetland, and the design team desires to fill these natural depressions, the designer evaluating the site and formulating a stormwater disposal concept will consider these natural depressions and replace any disturbed depressions. Normally, the natural storage volume lost due to the proposed earthwork must be replaced using a 1:1 ratio as a minimum. A higher ratio may be required if the new area infiltrates water at a lower rate than occurred in the natural depression. The road and drainage plans must include: (1) a grading plan of the closed depression area to be filled in, (2) both existing and finished grade contours, and (3) compaction and fill material requirements.

- For natural depressions that are capable of complete water disposal within 72 hours by infiltrating the runoff generated from a 100-year, 24-hour storm event, a properly designed grassed percolation area, or combination grassed percolation area/drywell that is equal or greater in volume and that will also completely infiltrate the runoff from a 100-year, 24-hour storm event within a 72-hour time period, could be an acceptable substitution.
- For natural depressions that do not drain within 72 hours, it is acceptable to consolidate all the volumes of the depressions from the subject site that are proposed for filling into one or more infiltration/evaporative ponds that will emulate the natural condition. If the site has a disposal area that will allow increased percolation from the natural condition, a Design Deviation may be granted for increased infiltration if it can be demonstrated that the groundwater levels in the area will not be adversely affected and runoff treatment problems will not increase.
- For sites with natural depressions, the designer must clearly identify the location of all depressions that could contain more than 50 cubic feet of stormwater. For these types of depressions, the designer must survey each depression and show the maximum volume that each could hold, as well as show the maximum storage capacity water elevation contour line on the predeveloped condition basin map. The basin map should show adequate survey data points to demonstrate that accurate volume calculations can be made from them. If the site contains many small depressions that will hold water, but are smaller than 50 cubic feet in size, the

designer must adjust the runoff factors to allow for this retention of stormwater or make other adjustments to the runoff model that are approved in writing by region or HQ hydraulics staff. If the site had depression storage in its historic natural state, and grading and filling have been done to these natural features, the designer must reasonably estimate the depression storage that was on the site and comply with the provisions of this section.

If the total storage capacity of a closed depression exceeds the maximum volume used (as computed using the water budget method), both volumes must be clearly identified in the Hydraulic Report, and both of these water surface elevation contour lines are to be shown in the basin map.

If a closed depression is to remain or be replaced, the lowest floor elevation or road grade of any building or road adjacent to it must be at or above the maximum water elevation and outside the limits of the closed depression. The maximum water elevation must be computed using the water budget method as per the standards for an evaporative systems design unless the pond can naturally drain within 72 hours following a 100-year, 24-hour storm event. If the depression can drain within the 72-hour time period, the maximum water elevation is computed as being the elevation containing the runoff from a 100-year, 24-hour storm event. If the limits of the high water in the infiltration facility are considered in the design, a geotechnical report must be provided that shows site-specific infiltration testing results and verifies that each depression being used will drain within the 72-hour period unless waived by region or HQ hydraulics staff based on knowledge of approved soils under the site. The closed depression must be placed in a drainage easement or separate tract if the development is noncommercial. The easement must be granted to WSDOT and any other entity responsible for maintaining the closed depression.

4-8 References

Brater, E.F. and H.W. King. 1976. Handbook of Hydraulics. McGraw-Hill Company, New York.

Chow, V.T. 1959. Open Channel Hydraulics. McGraw-Hill Book Company.

Daugherty, R.L. and J.B. Franzini. 1977. Fluid Mechanics with Engineering Applications. McGraw-Hill, New York.

Ecology, Washington State Department of. *Stormwater Management Manual for Western Washington*. August 2005.

Ecology, Washington State Department of. *Stormwater Management Manual for Eastern Washington*. September 2004.

King County Surface Water Management Division. 1999. King County Runoff Timeseries (KCRTS), *Computer Software Reference Manual*, Version 4.4. January 1999.

King County. *Washington Surface Water Design Manual*. September 1998.

“Low-Impact Development Design Strategies, An Integrated Design Approach,” prepared by Prince George’s County Maryland, Department of Environmental Resources, Programs and Planning Divisions. June 1999.

Maryland *Stormwater Manual*.

Massmann, J.W. 2003. *A Design Manual for Sizing Infiltration Ponds*. WSDOT, WA-RD 578.2. 61 pp.

Massmann, J.W. April 2004. *An Approach For Estimating Infiltration Rates For Stormwater Infiltration Drywells*, WSDOT, Agreement Y-7717 Task Order AU.

Massman, Joel, Carolyn Butchart, and Stephanie Stolar. 2003. University of Washington, Final Research Report-T1803, Task 12, “Infiltration Characteristics, Performance, and Design of Stormwater Facilities.”

Miller, J.F., R.H. Frederick, and R.S. Tracey. 1973. NOAA Atlas 2, Precipitation Frequency Atlas of the Western United States, Volume IX-Washington. U.S. Dept. of Commerce, NOAA, National Weather Service. Washington D.C.

Oregon Climate Service. 1997. Mean Annual Precipitation Maps for Western United States, prepared with PRISM Model for NRCS, Corvallis, Oregon.

Pierce County *Stormwater Manual*.

Pitt, R., S.E. Chen, S. Clark, J. Lantrip, C.K. Ong, and J. Voorhees. 2003. "Infiltration Through Compacted Urban Soils and Effects on Biofiltration Design," *Stormwater and Urban Water Systems Modeling, Models, and Applications to Urban Water Systems*, Ed. – W. James, CHI, Guelph, Ontario, Vol. 11. pp. 217-252.

Schaefer, M.G. 1981. "Shaft Spillways, Fundamental Hydraulics and Hydrology of Dam Design." University of Missouri Short Course, available through Dam Safety Section, Washington Department of Ecology. May 1981.

Schaefer, M.G. and B.L. Barker. 2002. "Extended Precipitation Time Series for continuous hydrological modeling in Western Washington," prepared for Washington State Department of Transportation by MGS Consulting Inc. April 2002.

Schaefer, M.G. and B.L. Barker. 2003. MGS Flood – *Proprietary Version User Manual*, prepared for Washington State Department of Transportation by MGS Consulting Inc., Version 2.2. March 2003.

U.S. Bureau of Reclamation. 1987. Design of Small Dams. U.S. Department of the Interior, U.S. Government Printing Office, 3rd edition.

USDA-SCS. 1986. Technical Release No. 55: Urban Hydrology for Small Watershed.

U.S. EPA. 1984. *Hydrological Simulation Program-Fortran HSPF User Manual* for Release 9. EPA 600/3-84-066. Environmental Research Laboratory, Athens, GA. June 1984.

APPENDIX 4A

Web Links

Appendix 4A. Web Links

Washington 2-hour Isopluvial Map, January 2006

www.wsdot.wa.gov/Design/Hydraulics/default.htm

Also available on the Environmental Workbench in ArcMap (internal WSDOT only).

wwwi.wsdot.wa.gov/GIS/supportteam/gis_workbench/GISWBQuickStart.pdf

Washington Mean Annual Precipitation Map

www.wsdot.wa.gov/Design/Hydraulics/default.htm

Also available on the Environmental Workbench in ArcMap (internal WSDOT only).

wwwi.wsdot.wa.gov/GIS/supportteam/gis_workbench/GISWBQuickStart.pdf

Washington 24-hour Isopluvial Maps, January 2006

www.wsdot.wa.gov/Design/Hydraulics/default.htm

www.wrcc.dri.edu/CLIMATEDATA.html

MGSFlood Users Manual

www.wsdot.wa.gov/Design/Hydraulics/Training.htm

MGSFlood Training Example

www.wsdot.wa.gov/Design/Hydraulics/Training.htm

StormSHED

www.wsdot.wa.gov/Design/Hydraulics/Training.htm

StormSHED Training Example

www.wsdot.wa.gov/Design/Hydraulics/Training.htm

Downstream Analysis

Provided in the 2006 *Hydraulics Manual*, Chapter 4:

www.wsdot.wa.gov/Design/Hydraulics/default.htm

Low-Impact Development (LID) Modeling

Provides guidance on how to model LID.

www.wsdot.wa.gov/Design/Hydraulics/default.htm

Time-to-Drain Infiltration Pond and Trench Spreadsheet

www.wsdot.wa.gov/Design/Hydraulics/Training.htm

MGSFlood CAVFS Example

www.wsdot.wa.gov/Design/Hydraulics/Training.htm

APPENDIX 4B

TR55 Curve Number Tables

Appendix 4B. List of Tables

Table 4B-1.	Hydrologic soil series for selected soils in Washington State.....	4B-1
Table 4B-2.	Runoff curve numbers for selected agricultural, suburban, and rural areas (western Washington).	4B-4
Table 4B-3.	Runoff curve numbers for selected agricultural, suburban, and rural areas (eastern Washington).	4B-5
Table 4B-4.	Curve number conversions for different antecedent moisture conditions (case Ia = 0.2 S).	4B-6
Table 4B-5.	“n” and “k” values used in time calculations for hydrographs.....	4B-7
Table 4B-6.	Values of the roughness coefficient, “n”.....	4B-8

Table 4B-1. Hydrologic soil series for selected soils in Washington State.

Soil Type	Hydrologic Soil Group	Soil Type	Hydrologic Soil Group
Agnew	C	Dimal	D
Ahl	B	Dragoon	C
Aits	C	Dupont	D
Alderwood	C	Earlmont	C
Arents, Alderwood	B	Edgewick	C
Arents, Everett	B	Eld	B
Ashoe	B	Eloika	B
Athena	B	Elwell	B
Baldhill	B	Emdent	D
Barneston	C	Esquatzel	B
Baumgard	B	Everett	A
Beausite	B	Everson	D
Belfast	C	Freeman	C
Bellingham	D	Galvin	D
Bellingham variant	C	Garfield	C
Bernhill	B	Garrison	B
Boistfort	B	Getchell	A
Bong	A	Giles	B
Bonner	B	Glenrose	B
Bow	D	Godfrey	D
Brickel	C	Green Bluff	B
Bridgeson	D	Greenwater	A
Briscot	D	Grove	C
Buckley	C	Hagen	B
Bunker	B	Hardesty	B
Cagey	C	Harstine	C
Caldwell	C	Hartnit	C
Carlsborg	A	Hesseltine	B
Casey	D	Hoh	B
Cassolary	C	Hoko	C
Cathcart	B	Hoodsport	C
Cedonia	B	Hoogdal	C
Centralia	B	Hoypus	A
Chehalis	B	Huel	A
Cheney	B	Indianola	A
Chesaw	A	Jonas	B
Cinebar	B	Jumpe	B
Clallam	C	Kalaloch	C
Clayton	B	Kapowsin	C/D
Coastal beaches	variable	Katula	C
Cocolalla	D	Kilchis	C
Colter	C	Kitsap	C
Custer	D	Klaus	C
Custer, Drained	C	Klone	B
Dabob	C	Konner	D

Table 4B-1. Hydrologic soil series for selected soils in Washington State (continued).

Soil Type	Hydrologic Soil Group	Soil Type	Hydrologic Soil Group
Dearyton	C	Lakesol	B
Delphi	D	Laketon	C
Dick	A	Lance	B
Larkin	B	Poulsbo	C
Latah	D	Prather	C
Lates	C	Puget	D
Lebam	B	Puyallup	B
Lummi	D	Queets	B
Lynnwood	A	Quilcene	C
Lystair	B	Ragnar	B
Mal	C	Rainier	C
Manley	B	Raught	B
Marble	A	Reardan	C
Mashel	B	Reed	D
Maytown	C	Reed, Drained or Protected	C
McKenna	D	Renton	D
McMurray	D	Republic	B
Melbourne	B	Riverwash	variable
Menzel	B	Rober	C
Mixed Alluvial	variable	Salal	C
Molson	B	Salkum	B
Mondovi	B	Sammamish	D
Moscow	C	San Juan	A
Mukilteo	C/D	Scamman	D
Naff	B	Schneider	B
Narcisse	C	Schumacher	B
Nargar	A	Seattle	D
National	B	Sekiu	D
Neilton	A	Semiahmoo	D
Newberg	B	Shalcar	D
Nez Perce	C	Shano	B
Nisqually	B	Shelton	C
Nooksack	C	Si	C
Norma	C/D	Sinclair	C
Ogarty	C	Skipopa	D
Olete	C	Skykomish	B
Olomount	C	Snahopish	B
Olympic	B	Snohomish	D
Orcas	D	Snow	B
Oridia	D	Solduc	B
Orting	D	Solleks	C
Oso	C	Spana	D
Ovall	C	Spanaway	A/B
Palouse	B	Speigle	B
Pastik	C	Spokane	C
Peone	D	Springdale	A
Pheeneey	C	Sulsavar	B

Table 4B-1. Hydrologic soil series for selected soils in Washington State (continued).

Soil Type	Hydrologic Soil Group	Soil Type	Hydrologic Soil Group
Phelan	D	Sultan	C
Phoebe	B	Sultan variant	B
Pilchuck	C	Sumas	C
Potchub	C	Swantown	D
Tacoma	D	Vailton	B
Tanwax	D	Vassar	B
Tanwax, Drained	C	Verlot	C
Tealwhit	D	Wapato	D
Tekoa	C	Warden	B
Tenino	C	Wethey	C
Tisch	D	Whidbey	C
Tokul	C	Wilkeson	B
Townsend	C	Winston	A
Triton	D	Wolfeson	C
Tukwila	D	Woodinville	B
Tukey	C	Yelm	C
Uhlig	B	Zynbar	B
Urbana	C		

Hydrologic Soil Group Classifications, as defined by the Soil Conservation Service:

- A** = (Low runoff potential) Soils having low runoff potential and high infiltration rates, even when thoroughly wetted. They consist chiefly of deep, well- to excessively drained sands or gravels, and have a high rate of water transmission (greater than 0.30 in/hr).
- B** = (Moderately low runoff potential) Soils having moderate infiltration rates when thoroughly wetted and consisting chiefly of moderately deep to deep, moderately well- to well-drained soils, with moderately fine to moderately coarse textures. These soils have a moderate rate of water transmission (0.15–0.3 in/hr).
- C** = (Moderately high runoff potential) Soils having low infiltration rates when thoroughly wetted and consisting chiefly of soils with a layer that impedes downward movement of water and soils with moderately fine to fine textures. These soils have a low rate of water transmission (0.05–0.15 in/hr).
- D** = (High runoff potential) Soils having high runoff potential. They have very low infiltration rates when thoroughly wetted and consist chiefly of clay soils with a high swelling potential; soils with a permanent high water table; soils with a hardpan or clay layer at or near the surface; and shallow soils over nearly impervious material. These soils have a very low rate of water transmission (0–0.05 in/hr).
- * = From SCS, TR-55, Second Edition, June 1986, Exhibit A-1. Revisions made from SCS, Soil Interpretation Record, Form #5, September 1988 and various county soil surveys.

This information can also be found online at: websoilsurvey.nrcs.usda.gov/app/WebSoilSurvey.aspx

Table 4B-2. Runoff curve numbers for selected agricultural, suburban, and rural areas (western Washington).

Cover Type and Hydrologic Condition	CNs for hydrologic soil group			
	A	B	C	D
Curve Numbers for Predevelopment Conditions				
Pasture, Grassland, or Range – Continuous Forage for Grazing:				
Fair condition (ground cover 50% to 75% and not heavily grazed)	49	69	79	84
Good condition (ground cover >75% and lightly or only occasionally grazed)	39	61	74	80
Woods:				
Fair (woods are grazed but not burned, and some forest litter covers the soil)	36	60	73	79
Good (woods are protected from grazing, and litter and brush adequately cover the soil)	30	55	70	77
Curve Numbers for Postdevelopment Conditions				
Open Space (lawns, parks, golf courses, cemeteries, landscaping, etc.):¹				
Fair condition (grass cover on 50% to 75% of the area)	77	85	90	92
Good condition (grass cover on >75% of the area)	68	80	86	90
Impervious Areas:				
Open water bodies: lakes, wetlands, ponds, etc.	100	100	100	100
Paved parking lots, roofs, ² driveways, etc. (excluding right of way)	98	98	98	98
Porous Pavers and Permeable Interlocking Concrete (assumed as 85% impervious and 15% lawn):				
Fair lawn condition (weighted average CNs)	95	96	97	97
Good lawn condition (weighted average CNs)	94	95	96	97
Paved	98	98	98	98
Gravel (including right of way)	76	85	89	91
Dirt (including right of way)	72	82	87	89
Pasture, Grassland, or Range – Continuous Forage for Grazing:				
Poor condition (ground cover <50% or heavily grazed with no mulch)	68	79	86	89
Fair condition (ground cover 50% to 75% and not heavily grazed)	49	69	79	84
Good condition (ground cover >75% and lightly or only occasionally grazed)	39	61	74	80
Woods:				
Poor (forest litter, small trees, and brush are destroyed by heavy grazing or regular burning)	45	66	77	83
Fair (woods are grazed but not burned, and some forest litter covers the soil)	36	60	73	79
Good (woods are protected from grazing, and litter and brush adequately cover the soil)	30	55	70	77
Single Family Residential:³				
Dwelling Unit/Gross Acre	Should only be used for subdivisions >50 acres		Average percent impervious area ^{3,4}	
1.0 DU/GA			15 Separate curve number	
1.5 DU/GA			20 must be selected for	
2.0 DU/GA			25 pervious & impervious	
2.5 DU/GA			30 portions of the site or	
3.0 DU/GA			34 basin	
3.5 DU/GA			38	
4.0 DU/GA			42	
4.5 DU/GA			46	
5.0 DU/GA			48	
5.5 DU/GA			50	
6.0 DU/GA			52	
6.5 DU/GA			54	
7.0 DU/GA			56	
7.5 DU/GA			58	
PUDs, condos, apartments, commercial businesses, industrial areas, and subdivisions <50 acres	% impervious must be computed		Separate curve numbers must be selected for pervious and impervious portions of the site	

For a more detailed and complete description of land use curve numbers, refer to Chapter Two (2) of the Soil Conservation Service's Technical Release No. 55 (210-VI-TR-55, Second Ed., June 1986).

¹ Composite CNs may be computed for other combinations of open space cover type.

² Where roof runoff and driveway runoff are infiltrated or dispersed according to the requirements in Chapter 3, the average percent impervious area may be adjusted in accordance with the procedure described under "Flow Credit for Roof Downspout Infiltration" and "Flow Credit for Roof Downspout Dispersion."

³ Assumes roof and driveway runoff is directed into street/storm system.

⁴ All remaining pervious area (lawn) is considered to be in good condition for these curve numbers.

Table 4B-3. Runoff curve numbers for selected agricultural, suburban, and rural areas (eastern Washington).

Cover Type and Hydrologic Condition	CNs for hydrologic soil group			
	A	B	C	D
Open Space (lawns, parks, golf courses, cemeteries, landscaping, etc.):¹				
Poor condition (grass cover on <50% of the area)	68	79	86	89
Fair condition (grass cover on 50% to 75% of the area)	49	69	79	84
Good condition (grass cover on >75% of the area)	39	61	74	80
Impervious Areas:				
Open water bodies: lakes, wetlands, ponds, etc.	100	100	100	100
Paved parking lots, roofs, driveways, etc. (excluding right of way)	98	98	98	98
Porous Pavers and Permeable Interlocking Concrete (assumed as 85% impervious and 15% lawn):				
Fair lawn condition (weighted average CNs)	95	96	97	97
Gravel (including right of way)	76	85	89	91
Dirt (including right of way)	72	82	87	89
Pasture, Grassland, or Range – Continuous Forage for Grazing:				
Poor condition (ground cover <50% or heavily grazed with no mulch)	68	79	86	89
Fair condition (ground cover 50% to 75% and not heavily grazed)	49	69	79	84
Good condition (ground cover >75% and lightly or only occasionally grazed)	39	61	74	80
Cultivated Agricultural Lands:				
Row Crops (good), e.g., corn, sugar beets, soy beans	64	75	82	85
Small Grain (good), e.g., wheat, barley, flax	60	72	80	84
Meadow (continuous grass, protected from grazing, and generally mowed for hay):	30	58	71	78
Brush (brush-weed-grass mixture, with brush the major element):				
Poor (<50% ground cover)	48	67	77	83
Fair (50% to 75% ground cover)	35	56	70	77
Good (>75% ground cover)	30 ²	48	65	73
Woods-Grass Combination (orchard or tree farm):³				
Poor	57	73	82	86
Fair	43	65	76	82
Good	32	58	72	79
Woods:				
Poor (forest litter, small trees, and brush are destroyed by heavy grazing or regular burning)	45	66	77	83
Fair (woods are grazed but not burned, and some forest litter covers the soil)	36	60	73	79
Good (woods are protected from grazing, and litter and brush adequately cover the soil)	30	55	70	77
Herbaceous (mixture of grass, weeds, and low-growing brush, with brush the minor element):⁴				
Poor (<30% ground cover)		80	87	93
Fair (30% to 70% ground cover)		71	81	89
Good (>70% ground cover)		62	74	85
Sagebrush With Grass Understory:⁴				
Poor (<30% ground cover)		67	80	85
Fair (30% to 70% ground cover)		51	63	70
Good (>70% ground cover)		35	47	55

For a more detailed and complete description of land use curve numbers, refer to Chapter Two (2) of the Soil Conservation Service's Technical Release No. 55 (210-VI-TR-55, Second Ed., June 1986).

¹ Composite CNs may be computed for other combinations of open space cover type.

² Actual curve number is less than 30; use CN = 30 for runoff computations.

³ CNs shown were computed for areas with 50% woods and 50% grass (pasture) cover. Other combinations of conditions may be computed from the CNs for woods and pasture.

⁴ Curve numbers have not been developed for Group A soils.

Table 4B-4. Curve number conversions for different antecedent moisture conditions (case Ia = 0.2 S).

CN for AMC II	CN for AMC I	CN for AMC III	CN for AMC II	CN for AMC I	CN for AMC III
100	100	100	76	58	89
99	97	100	75	57	88
98	94	99	74	55	88
97	91	99	73	54	87
96	89	99	72	53	86
95	87	98	71	52	86
94	85	98	70	51	85
93	83	98	69	50	84
92	81	97	68	48	84
91	80	97	67	47	83
90	78	96	66	46	82
89	76	96	65	45	82
88	75	95	64	44	81
87	73	95	63	43	80
86	72	94	62	42	79
85	70	94	61	41	78
84	68	93	60	40	78
83	67	93	59	39	78
82	66	92	58	38	76
81	64	92	57	37	75
80	63	91	56	36	75
79	62	91	55	35	74
78	60	90	54	34	73
77	59	89	50	31	70

Source: SCS-NEH4, Table 10.1.

Table 4B-5. “n” and “k” values used in time calculations for hydrographs.

“n_s” Sheet Flow Equation Manning’s Values (for the initial 300 ft. of travel)	
Manning’s Values for sheet flow only; from Overton and Meadows 1976 (see TR-55, 1986)	n_s
Smooth surfaces (concrete, asphalt, gravel, or bare, hand-packed soil)	0.011
Fallow fields or loose soil surface (no residue)	0.05
Cultivated soil with residue cover ≤20%	0.06
Cultivated soil with residue cover >20%	0.17
Short prairie grass and lawns	0.15
Dense grasses	0.24
Bermuda grass	0.41
Range (natural)	0.13
Woods or forest with light underbrush	0.40
Woods or forest with dense underbrush	0.80
(210-VI-TR-55, Second Ed., June 1986)	
“k” Values Used in Travel Time/Time of Concentration Calculations	
Shallow Concentrated Flow (after the initial 300 ft. of sheet flow, R = 0.1)	k_s
1. Forest with heavy ground litter and meadows (n = 0.10)	3
2. Brushy ground with some trees (n = 0.060)	5
3. Fallow or minimum tillage cultivation (n = 0.040)	8
4. High grass (n = 0.035)	9
5. Short grass, pasture, and lawns (n = 0.030)	11
6. Nearly bare ground (n = 0.025)	13
7. Paved and gravel areas (n = 0.012)	27
Channel Flow (intermittent) (at the beginning of visible channels, R = 0.2)	k_c
1. Forested swale with heavy ground litter (n = 0.10)	5
2. Forested drainage course/ravine with defined channel bed (n = 0.050)	10
3. Rock-lined waterway (n = 0.035)	15
4. Grassed waterway (n = 0.030)	17
5. Earth-lined waterway (n = 0.025)	20
6. CMP pipe, uniform flow (n = 0.024)	21
7. Concrete pipe, uniform flow (0.012)	42
8. Other waterways and pipe	0.508/n
Channel Flow (continuous stream, R = 0.4)	k_c
9. Meandering stream with some pools (n = 0.040)	20
10. Rock-lined stream (n = 0.035)	23
11. Grass-lined stream (n = 0.030)	27
12. Other streams, manmade channels, and pipe	0.807/n

Table 4B-6. Values of the roughness coefficient, “n.”

Type of Channel and Description	Manning’s “n”* (Normal)	Type of Channel and Description	Manning’s “n”* (Normal)
A. Constructed Channels		6. Sluggish reaches, weedy deep pools	0.070
a. <i>Earth, straight and uniform</i>		7. Very weedy reaches, deep pools, or floodways with heavy stand of timber and underbrush	0.100
1. Clean, recently completed	0.018		
2. Gravel, uniform selection, clean	0.025	b. <i>Mountain streams, no vegetation in channel, banks usually steep, trees and brush along banks submerged at high stages</i>	
3. With short grass, few weeds	0.027	1. Bottom: gravel, cobbles, and few boulders	0.040
b. <i>Earth, winding and sluggish</i>		2. Bottom: cobbles with large boulders	0.050
1. No vegetation	0.025	B-2 Flood plains	
2. Grass, some weeds	0.030	a. <i>Pasture, no brush</i>	
3. Dense weeds or aquatic plants in deep channels	0.035	1. Short grass	0.030
4. Earth bottom and rubble sides	0.030	2. High grass	0.035
5. Stony bottom and weedy banks	0.035	b. <i>Cultivated areas</i>	
6. Cobble bottom and clean sides	0.040	1. No crop	0.030
c. <i>Rock-lined</i>		2. Mature row crops	0.035
1. Smooth and uniform	0.035	3. Mature field crops	0.040
2. Jagged and irregular	0.040	c. <i>Brush</i>	
d. <i>Channels not maintained, weeds and brush uncut</i>		1. Scattered brush, heavy weeds	0.050
1. Dense weeds, high as flow depth	0.080	2. Light brush and trees	0.060
2. Clean bottom, brush on sides	0.050	3. Medium to dense brush	0.070
3. Same, highest stage of flow	0.070	4. Heavy, dense brush	0.100
4. Dense brush, high stage	0.100	d. <i>Trees</i>	
B. Natural Streams		1. Dense willows, straight	0.150
B-1 Minor streams (top width at flood stage < 100 ft.)		2. Cleared land with tree stumps, no sprouts	0.040
a. <i>Streams on plain</i>		3. Same as above, but with heavy growth of sprouts	0.060
1. Clean, straight, full stage, no rifts or deep pools	0.030	4. Heavy stand of timber, a few downed trees, little undergrowth, flood stage below branches	0.100
2. Same as above, but more stones and weeds	0.035	5. Same as above, but with flood stage reaching branches	0.120
3. Clean, winding, some pools and shoals	0.040		
4. Same as above, but some weeds	0.040		
5. Same as 4, but more stones	0.050		

* Note: These “n” values are “normal” values for use in analysis of channels. For conservative design for channel capacity, the maximum values listed in other references should be considered. For channel bank stability, the minimum values should be considered.

**Eastern Washington
Design Storm Events**

Appendix 4C. Table of Contents

Appendix 4C	Eastern Washington Design Storm Events.....	1
4C-1	SCS Type II and Type 1A Hyetographs.....	1
4C-2	Custom Design Storm Hyetographs.....	1
4C-3	Storm Analysis.....	4
4C-4	Antecedent Moisture Condition.....	6
4C-5	Precipitation Magnitude/Frequency Analysis.....	8
4C-6	Precipitation Magnitude for 24-Hour and Long- and Short-Duration Runoff Treatment Storm.....	18
4C-7	Precipitation Magnitude for Long-Duration Storms.....	18
4C-7.1	Precipitation Magnitude for Short-Duration Storms.....	19

List of Tables

Table 4C-1.	Antecedent precipitation prior to long-duration storm.	7
Table 4C-2.	Total 5-day antecedent rainfall (inches).	7
Table 4C-3.	SCS Type 1A storm hyetograph values.	9
Table 4C-3.	SCS Type IA storm hyetograph values (continued).	10
Table 4C-4.	SCS Type II storm hyetograph values.	11
Table 4C-4.	SCS Type II storm hyetograph values (continued).	12
Table 4C-5.	Short-duration storm hyetograph values: All regions.	13
Table 4C-6.	Long-duration storm hyetograph values: Region 1 – Cascade Mountains.	14
Table 4C-7.	Long-duration storm hyetograph values: Region 2 – Central Basin.	15
Table 4C-8.	Long-duration storm hyetograph values: Region 3 – Okanogan, Spokane, Palouse.	16
Table 4C-9.	Long-duration storm hyetograph values: Region 4 – Northeastern Mountains and Blue Mountains.	17
Table 4C-10.	Coefficients C_{wqs} for computing 6-month, 24-hour precipitation.	18
Table 4C-11.	Conversion factor for 24-hour to regional long-duration storm precipitation.	19
Table 4C-12.	Precipitation for selected return periods (C_{sds}).	20

List of Figures

Figure 4C-1.	SCS Type 1A hyetograph.	2
Figure 4C-2.	SCS Type II hyetograph.	2
Figure 4C-3.	Short-duration storm unit hyetograph.	5
Figure 4C-4.	Sample long-duration storm hyetograph.	6

Appendix 4C.

Eastern Washington Design Storm Events

The design storms to be used in eastern Washington are based on two parameters:

- Total rainfall volume (depth in inches)
- Rainfall distribution (dimensionless)

The design storm event is specified by return period (months and/or years) and duration. The following sections explain total rainfall depth and rainfall distribution associated with a design storm.

All storm event hydrograph methods require the input of a rainfall distribution or design storm hyetograph. Essentially, the design storm hyetograph is a plot of rainfall depth versus time for a given design period and duration. It is usually presented as a dimensionless plot of unit rainfall depth (incremental rainfall depth for each time interval divided by the total rainfall depth) versus time.

Design storm distribution for all eastern Washington Climatic Regions – 1, 2, 3, and 4:

- **Flow-Based BMPs:** The short-duration storm distribution.
- **Volume-Based BMPs:** The SCS Type 1A storm distribution (Regions 2 and 3) or the regional long-duration storm (Regions 1–4).

4C-1 SCS Type II and Type 1A Hyetographs

The Type II hyetograph is a standard SCS (NRCS) rainfall distribution that has a high intensity peak. It has been used in eastern Washington since the 1970s and is also used throughout much of the United States. The Type IA hyetograph is also a standard NRCS rainfall distribution. It is applicable to western Washington and Climatic Regions 2 and 3 in eastern Washington. These are two of four 24-hour storm distribution types commonly used in SCS hydrograph methods.

For graphical representation of these two SCS hyetographs, see Figures 4C-1 and 4C-2. Tabular values of these hyetographs are in Tables 4C-3 and 4C-4.

4C-2 Custom Design Storm Hyetographs

When rainfall patterns during storms were analyzed in eastern Washington (see Appendix 4A), it was concluded that the SCS Type II rainfall distribution does not match the historical records for two storm types of interest for stormwater analyses in eastern Washington: the short-duration thunderstorm and the long-duration winter storm.

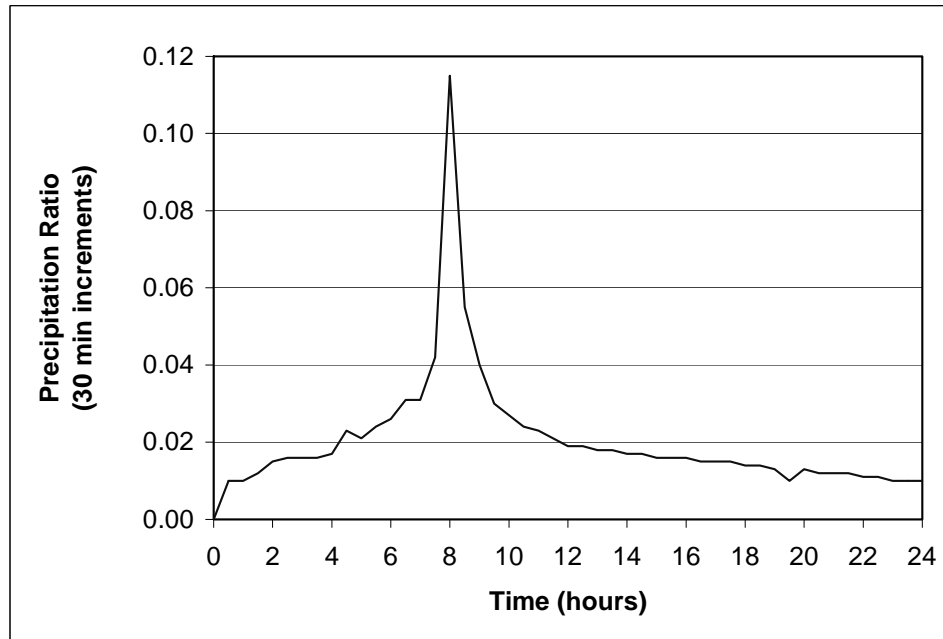

Figure 4C-1. SCS Type 1A hyetograph.

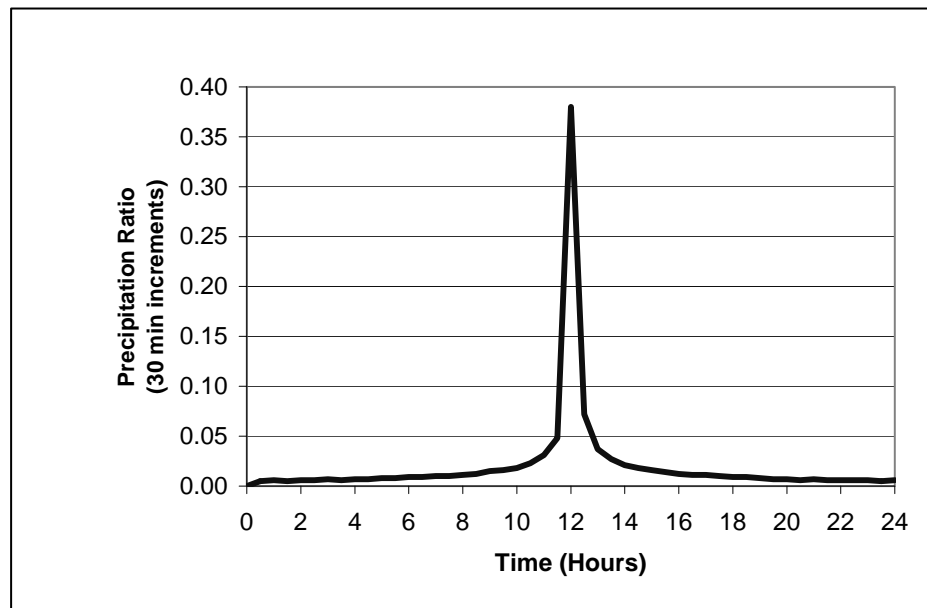
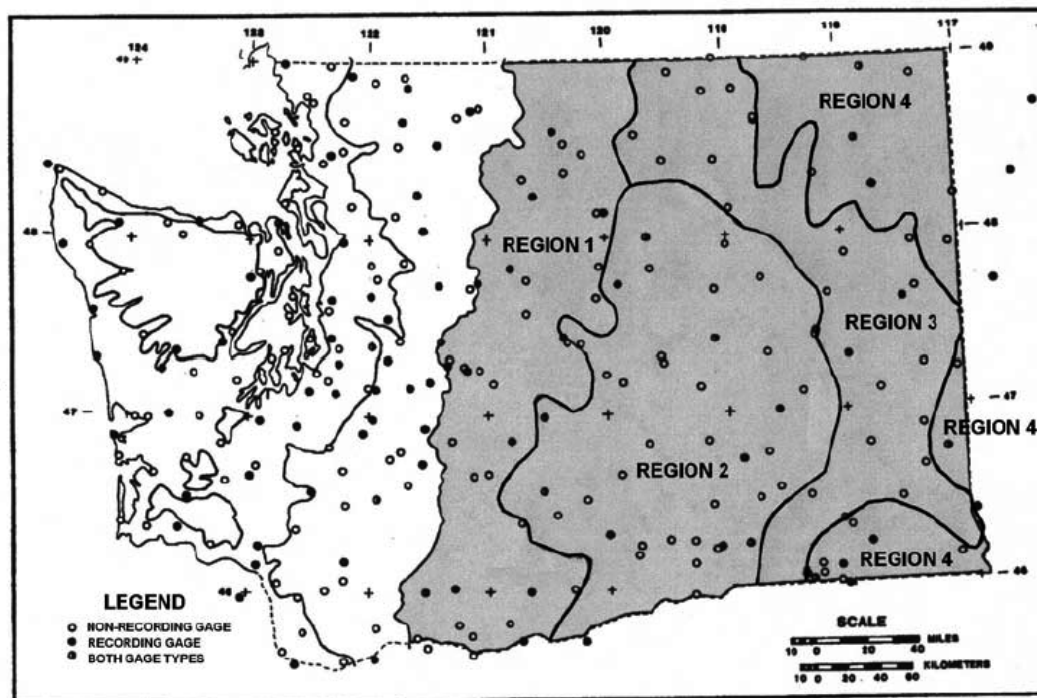

Figure 4C-2. SCS Type II hyetograph.

Short-duration thunderstorms can occur in late spring through early fall and are characterized by high intensities for short periods of time over localized areas. These types of storms can produce high rates of runoff and flash flooding in urban areas and are important where flood peak discharge and/or erosion are design considerations.

Long-duration general storms can occur at any time of the year, but are more common in late fall through winter and in late spring and early summer. General storms in eastern Washington are characterized by sequences of storms and intervening dry periods, often occurring over several days. Low-to-moderate intensity precipitation is typical during the periods of storm activity. These types of events can produce floods with moderate peak discharge and large runoff volumes. The runoff volume can be augmented by snowmelt when precipitation falls on snow during winter and early spring storms. These types of storm events are important where both runoff volume and peak discharge are design considerations.

When using the custom design storms, it is necessary to note that eastern Washington has been divided into four climatic regions to reflect the differences in storm characteristics and the seasonality of storms. The four climatic regions are shown as follows:



Region 1 – East Slopes of the Cascade Mountains

This region is comprised of mountain areas on the east slopes of the Cascade Mountains. It is bounded on the west by the Cascade crest and generally bounded to the east by the contour line of 16 inches mean annual precipitation.

Region 2 – Central Basin

The Central Basin Region is comprised of the Columbia Basin and adjacent low elevation areas in central Washington. It is generally bounded on the west by the contour line of 16 inches mean annual precipitation at the base of the east slopes of the Cascade Mountains. The region is bounded on the north and east by the contour line of 12 inches mean annual precipitation. Most of this region receives about 8 inches of mean annual precipitation. Many of the larger cities in eastern Washington are in this region, including Ellensburg, Kennewick, Moses Lake, Pasco, Richland, Wenatchee, and Yakima.

Region 3 – Okanogan, Spokane, Palouse

This region is comprised of intermountain areas and includes areas near Okanogan, Spokane, and the Palouse. It is bounded on the northwest by the contour line of 16 inches mean annual precipitation at the base of the east slopes of the Cascade Mountains. It is bounded on the south and west by the contour line of 12 inches mean annual precipitation at the eastern edge of the Central Basin. It is bounded on the northeast by the Kettle River Range and Selkirk Mountains at approximately the contour line of 22 inches mean annual precipitation. It is bounded on the southeast by the Blue Mountains; also at the contour line of 22 inches mean annual precipitation.

Region 4 – Northeastern Mountains and Blue Mountains

This region is comprised of mountain areas in the easternmost part of Washington State. It includes portions of the Kettle River Range and Selkirk Mountains in the northeast and the Blue Mountains in the southeast corner of eastern Washington. Mean annual precipitation ranges from a minimum of 22 inches to over 60 inches. The western boundary of this region is the contour line of 22 inches mean annual precipitation.

4C-3 Storm Analysis

Based on analyses of historical storms in eastern Washington, it has been concluded that the short-duration summer thunderstorm typically generates the greatest peak discharges for small urban watersheds. Use of short-duration thunderstorms is therefore appropriate for designing conveyance structures and biofiltration swales. Analyses also indicate that the long-duration winter storm typically generates the greatest runoff volume. Long-duration design storms are therefore appropriate for designing stormwater detention and runoff treatment facilities where runoff volume is the primary concern. The Type 1A storm distribution is used for volume-based BMPs in Climatic Regions 2 and 3, or the regional long-duration distribution can be used in Climatic Regions 1–4.

Based on these analyses, synthetic design storms were developed for the short-duration thunderstorm and long-duration winter storm. The design storms were developed in a manner that replicated temporal characteristics observed in storms from areas climatologically similar to eastern Washington.

- **Short-Duration Storm**

Short duration, high intensity, and smaller volumes characterize summer thunderstorms. The short-duration storm was selected to be 3 hours in duration. The storm temporal pattern is shown in Figure 4C-3 as a unit hyetograph. Tabular values are listed in Table 4C-5. Total precipitation is 1.06 times the 2-year, 2-hour precipitation amount to derive the 2-year, 3-hour storm. (See Table 4C-12 for further guidance.) There is one short-duration storm for all climatic regions in eastern Washington.

- **Long-Duration Storm** (varies by region)

The long-duration storm varies by region and is comprised of a series of storm events separated by a dry intervening period, occurring during a 72-hour period of time. A sample 72-hour long-duration storm hyetograph is shown in Figure 4C-4.

The smaller event (from 6 to 21 hours, above) is insufficient to generate the runoff that is present when the larger precipitation commences. For that reason, it is not necessary to directly model the smaller precipitation event. Only the larger portion (commencing at 36 hours, as shown above) is necessary to directly model.

The larger portion is similar to the 24-hour SCS Type 1A storm. For Climatic Regions 2 and 3, the SCS Type IA storm is sufficiently similar to the four regional long-duration storm hyetographs to use directly.

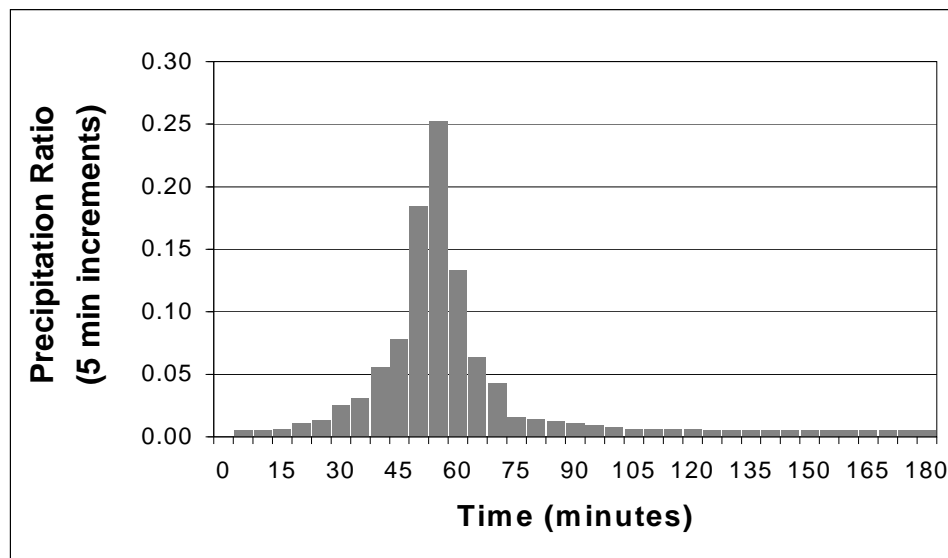

Figure 4C-3. Short-duration storm unit hyetograph.

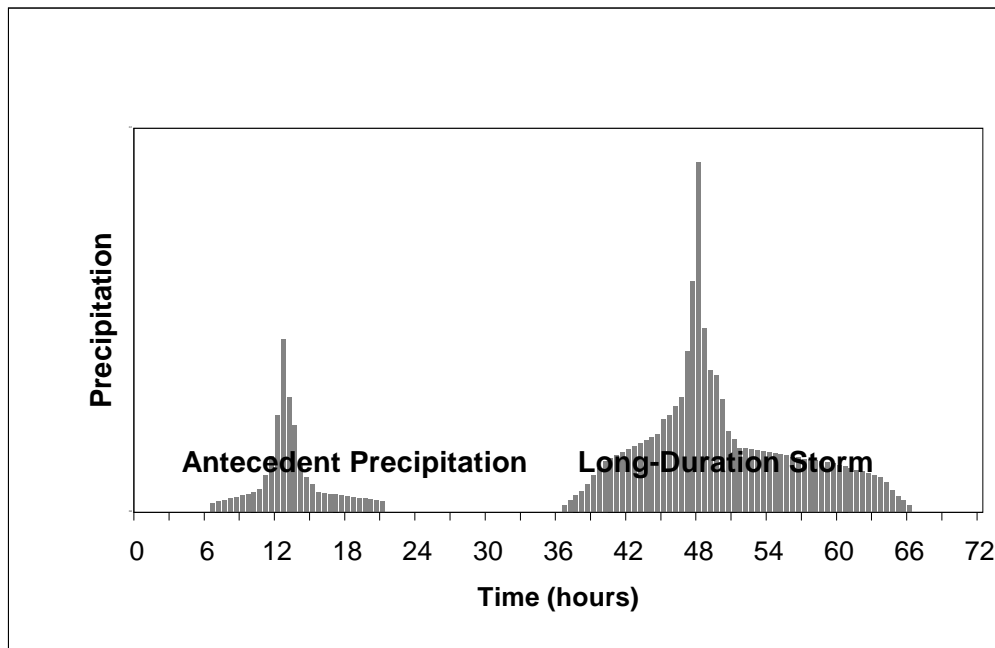

Figure 4C-4. Sample long-duration storm hyetograph.

Tabular values of the regional long-duration storm hyetographs are listed in Tables 4C-8 to 4C-11.

If the 24-hour SCS Type 1A storm is used for the long-duration storm, the precipitation totals are the 24-hour amounts without adjustment. If the regional long-duration hyetographs are used, the precipitation totals need to be adjusted as indicated for Regions 1 and 4, using Table 4C-11.

4C-4 Antecedent Moisture Condition

Regardless whether the 24-hour SCS Type 1A or regional hyetographs are used for long-duration storm modeling, the prior soil wetting produced by the smaller storm event (from 6 hours to 21 hours, above) that is not modeled needs to be accounted for. The amount of antecedent precipitation can be expressed as a percentage of the total precipitation modeled, as shown in Table 4C-3.

Curve number adjustments are to be considered, based on engineering analysis and judgment of the antecedent precipitation, soils characteristics, and surface conditions. The Antecedent Moisture Condition (AMC) is one basis for adjustment. Another is use of the Soil Conservation Service county surveys that include estimates of permeability and/or infiltration rates. Following is an example of the AMC:

For a 25-year Type 1A storm in Spokane (2.2"), determine whether AMC adjustments need to be considered in the analysis. If so, take the following steps:

1. From Table 4C-1, multiply 2.2" by 27% (Region 3), which equals 0.7". This is the amount of precipitation from the first hump of the long-duration storm.

Table 4C-1. Antecedent precipitation prior to long-duration storm.

Region #	Region Name	Antecedent Precipitation as Percentage of 24-Hour SCS Type 1A Storm Precipitation
1	East Slope Cascades	33%
2	Central Basin	19%
3	Okanogan, Spokane, Palouse	27%
4	NE & Blue Mountains	36%

Region #	Region Name	Antecedent Precipitation as Percentage of Regional Long-Duration Storm Hyetograph Precipitation
1	East Slope Cascades	28%
2	Central Basin	19%
3	Okanogan, Spokane, Palouse	25%
4	NE & Blue Mountains	34%

2. Next, determine whether the AMC will affect the CN values using Table 4C-2. If the precipitation from the first storm is over 1.1 or less than 0.5, the CN value will need to be adjusted using Appendix 4B. CN values are generally assumed to be AMC II.

Table 4C-2. Total 5-day antecedent rainfall (inches).

AMC	Dormant Season	Growing Season
I	Less than 0.5	Less than 1.4
II	0.5 to 1.1	1.4 to 2.1
III	Over 1.1	Over 2.1

4C-5 Precipitation Magnitude/Frequency Analysis

The current source for precipitation magnitude/frequency estimates is NOAA Atlas II, which is based on data collected from about 1940 through 1966, and NOAA Technical Report Number 36, which uses data through the late 1970s. In both of these studies, precipitation statistics were computed for each gage and used to produce point precipitation estimates at each site. The accuracy of the estimates was strongly related to the length of record at each site. Better estimates were obtained for more common events, with lesser accuracy for more rare events.

NOAA published the total depth of rainfall (in tenths of an inch) for storms of 24-hour duration and 2-, 5-, 10-, 25-, 50-, and 100-year recurrence intervals. The information is presented in the form of "isopluvial" maps for each state. Isopluvial maps are contour maps where the contours represent total inches of rainfall for a specific duration.

The web link to the isopluvial map for eastern Washington for the 2-year recurrence interval for the 2-hour duration storm event is in Appendix 4A. This map is from the Dam Safety Guidelines, Technical Note 3, Design Storm Construction, Washington State Department of Ecology, Water Resources Program, Report 92-55G, April 1993. This map is used for designs based on the short-duration storm.

Web links to the isopluvial maps for eastern Washington for the 2-, 10-, 25-, 50- and 100-year recurrence interval for 24-hour duration storm events is in Appendix 4A. These are excerpted from NOAA Atlas 2. The 24-hour isopluvial maps are used for designs based on the long-duration storm and 24-hour storms.

Table 4C-3. SCS Type 1A storm hyetograph values.

Time (0.1 hours)	Incremental Rainfall	Cumulative Rainfall
0.0	0.000	0.000
0.1	0.002	0.002
0.2	0.002	0.004
0.3	0.002	0.006
0.4	0.002	0.008
0.5	0.002	0.010
0.6	0.002	0.012
0.7	0.002	0.014
0.8	0.002	0.016
0.9	0.002	0.018
1.0	0.002	0.020
1.1	0.003	0.023
1.2	0.003	0.026
1.3	0.003	0.029
1.4	0.003	0.032
1.5	0.003	0.035
1.6	0.003	0.038
1.7	0.003	0.041
1.8	0.003	0.044
1.9	0.003	0.047
2.0	0.003	0.050
2.1	0.003	0.053
2.2	0.003	0.056
2.3	0.004	0.060
2.4	0.003	0.063
2.5	0.003	0.066
2.6	0.003	0.069
2.7	0.003	0.072
2.8	0.004	0.076
2.9	0.003	0.079
3.0	0.003	0.082
3.1	0.003	0.085
3.2	0.003	0.088
3.3	0.003	0.091
3.4	0.004	0.095
3.5	0.003	0.098
3.6	0.003	0.101
3.7	0.004	0.105
3.8	0.004	0.109
3.9	0.003	0.112
4.0	0.004	0.116
4.1	0.004	0.120
4.2	0.003	0.123
4.3	0.004	0.127
4.4	0.004	0.131

Time (0.1 hours)	Incremental Rainfall	Cumulative Rainfall
4.5	0.004	0.135
4.6	0.004	0.139
4.7	0.004	0.143
4.8	0.004	0.147
4.9	0.005	0.152
5.0	0.004	0.156
5.1	0.005	0.161
5.2	0.004	0.165
5.3	0.005	0.170
5.4	0.005	0.175
5.5	0.005	0.180
5.6	0.005	0.185
5.7	0.005	0.190
5.8	0.005	0.195
5.9	0.005	0.200
6.0	0.006	0.206
6.1	0.006	0.212
6.2	0.006	0.218
6.3	0.006	0.224
6.4	0.007	0.231
6.5	0.006	0.237
6.6	0.006	0.243
6.7	0.006	0.249
6.8	0.006	0.255
6.9	0.006	0.261
7.0	0.007	0.268
7.1	0.007	0.275
7.2	0.008	0.283
7.3	0.008	0.291
7.4	0.009	0.300
7.5	0.010	0.310
7.6	0.021	0.331
7.7	0.024	0.355
7.8	0.024	0.379
7.9	0.024	0.403
8.0	0.022	0.425
8.1	0.014	0.439
8.2	0.013	0.452
8.3	0.010	0.462
8.4	0.010	0.472
8.5	0.008	0.480
8.6	0.009	0.489
8.7	0.009	0.498
8.8	0.007	0.505
8.9	0.008	0.513

Time (0.1 hours)	Incremental Rainfall	Cumulative Rainfall
9.0	0.007	0.520
9.1	0.007	0.527
9.2	0.006	0.533
9.3	0.006	0.539
9.4	0.006	0.545
9.5	0.005	0.550
9.6	0.006	0.556
9.7	0.005	0.561
9.8	0.006	0.567
9.9	0.005	0.572
10.0	0.005	0.577
10.1	0.005	0.582
10.2	0.005	0.587
10.3	0.005	0.592
10.4	0.004	0.596
10.5	0.005	0.601
10.6	0.005	0.606
10.7	0.004	0.610
10.8	0.005	0.615
10.9	0.005	0.620
11.0	0.004	0.624
11.1	0.004	0.628
11.2	0.005	0.633
11.3	0.004	0.637
11.4	0.004	0.641
11.5	0.004	0.645
11.6	0.004	0.649
11.7	0.004	0.653
11.8	0.004	0.657
11.9	0.003	0.660
12.0	0.004	0.664
12.1	0.004	0.668
12.2	0.003	0.671
12.3	0.004	0.675
12.4	0.004	0.679
12.5	0.004	0.683
12.6	0.004	0.687
12.7	0.003	0.690
12.8	0.004	0.694
12.9	0.003	0.697
13.0	0.004	0.701
13.1	0.004	0.705
13.2	0.003	0.708
13.3	0.004	0.712
13.4	0.004	0.716

Table 4C-3. SCS Type IA storm hyetograph values (continued).

Time (0.1 hours)	Incremental Rainfall	Cumulative Rainfall
13.5	0.003	0.719
13.6	0.003	0.722
13.7	0.004	0.726
13.8	0.003	0.729
13.9	0.004	0.733
14.0	0.003	0.736
14.1	0.003	0.739
14.2	0.004	0.743
14.3	0.003	0.746
14.4	0.003	0.749
14.5	0.004	0.753
14.6	0.003	0.756
14.7	0.003	0.759
14.8	0.004	0.763
14.9	0.003	0.766
15.0	0.003	0.769
15.1	0.003	0.772
15.2	0.004	0.776
15.3	0.003	0.779
15.4	0.003	0.782
15.5	0.003	0.785
15.6	0.003	0.788
15.7	0.004	0.792
15.8	0.003	0.795
15.9	0.003	0.798
16.0	0.003	0.801
16.1	0.003	0.804
16.2	0.003	0.807
16.3	0.003	0.810
16.4	0.003	0.813
16.5	0.003	0.816
16.6	0.003	0.819
16.7	0.003	0.822
16.8	0.003	0.825
16.9	0.003	0.828
17.0	0.003	0.831
17.1	0.003	0.834
17.2	0.003	0.837
17.3	0.003	0.840
17.4	0.003	0.843
17.5	0.003	0.846
17.6	0.003	0.849
17.7	0.002	0.851
17.8	0.003	0.854
17.9	0.003	0.857

Time (0.1 hours)	Incremental Rainfall	Cumulative Rainfall
18.0	0.003	0.860
18.1	0.003	0.863
18.2	0.002	0.865
18.3	0.003	0.868
18.4	0.003	0.871
18.5	0.003	0.874
18.6	0.002	0.876
18.7	0.003	0.879
18.8	0.003	0.882
18.9	0.002	0.884
19.0	0.003	0.887
19.1	0.003	0.890
19.2	0.002	0.892
19.3	0.003	0.895
19.4	0.002	0.897
19.5	0.003	0.900
19.6	0.003	0.903
19.7	0.002	0.905
19.8	0.003	0.908
19.9	0.002	0.910
20.0	0.003	0.913
20.1	0.002	0.915
20.2	0.003	0.918
20.3	0.002	0.920
20.4	0.002	0.922
20.5	0.003	0.925
20.6	0.002	0.927
20.7	0.003	0.930
20.8	0.002	0.932
20.9	0.002	0.934
21.0	0.003	0.937
21.1	0.002	0.939
21.2	0.002	0.941
21.3	0.003	0.944
21.4	0.002	0.946
21.5	0.002	0.948
21.6	0.003	0.951
21.7	0.002	0.953
21.8	0.002	0.955
21.9	0.002	0.957
22.0	0.002	0.959
22.1	0.003	0.962
22.2	0.002	0.964
22.3	0.002	0.966
22.4	0.002	0.968

Time (0.1 hours)	Incremental Rainfall	Cumulative Rainfall
22.5	0.002	0.970
22.6	0.002	0.972
22.7	0.002	0.974
22.8	0.002	0.976
22.9	0.002	0.978
23.0	0.002	0.980
23.1	0.002	0.982
23.2	0.002	0.984
23.3	0.002	0.986
23.4	0.002	0.988
23.5	0.002	0.990
23.6	0.002	0.992
23.7	0.002	0.994
23.8	0.002	0.996
23.9	0.002	0.998
24.0	0.002	1.000

Table 4C-4. SCS Type II storm hyetograph values.

Time (0.1 hours)	Incremental Rainfall	Cumulative Rainfall
0.0	0.000	0.000
0.1	0.001	0.001
0.2	0.001	0.002
0.3	0.001	0.003
0.4	0.001	0.004
0.5	0.001	0.005
0.6	0.001	0.006
0.7	0.001	0.007
0.8	0.001	0.008
0.9	0.001	0.009
1.0	0.002	0.011
1.1	0.001	0.012
1.2	0.001	0.013
1.3	0.001	0.014
1.4	0.001	0.015
1.5	0.001	0.016
1.6	0.001	0.017
1.7	0.001	0.018
1.8	0.002	0.020
1.9	0.001	0.021
2.0	0.001	0.022
2.1	0.001	0.023
2.2	0.001	0.024
2.3	0.002	0.026
2.4	0.001	0.027
2.5	0.001	0.028
2.6	0.001	0.029
2.7	0.002	0.031
2.8	0.001	0.032
2.9	0.001	0.033
3.0	0.002	0.035
3.1	0.001	0.036
3.2	0.001	0.037
3.3	0.001	0.038
3.4	0.002	0.040
3.5	0.001	0.041
3.6	0.001	0.042
3.7	0.002	0.044
3.8	0.001	0.045
3.9	0.002	0.047
4.0	0.001	0.048
4.1	0.001	0.049
4.2	0.002	0.051
4.3	0.001	0.052
4.4	0.002	0.054

Time (0.1 hours)	Incremental Rainfall	Cumulative Rainfall
4.5	0.001	0.055
4.6	0.002	0.057
4.7	0.001	0.058
4.8	0.002	0.060
4.9	0.001	0.061
5.0	0.002	0.063
5.1	0.002	0.065
5.2	0.001	0.066
5.3	0.002	0.068
5.4	0.002	0.070
5.5	0.001	0.071
5.6	0.002	0.073
5.7	0.002	0.075
5.8	0.001	0.076
5.9	0.002	0.078
6.0	0.002	0.080
6.1	0.002	0.082
6.2	0.002	0.084
6.3	0.001	0.085
6.4	0.002	0.087
6.5	0.002	0.089
6.6	0.002	0.091
6.7	0.002	0.093
6.8	0.002	0.095
6.9	0.002	0.097
7.0	0.002	0.099
7.1	0.002	0.101
7.2	0.002	0.103
7.3	0.002	0.105
7.4	0.002	0.107
7.5	0.002	0.109
7.6	0.002	0.111
7.7	0.002	0.113
7.8	0.003	0.116
7.9	0.002	0.118
8.0	0.002	0.120
8.1	0.002	0.122
8.2	0.003	0.125
8.3	0.002	0.127
8.4	0.003	0.130
8.5	0.002	0.132
8.6	0.003	0.135
8.7	0.003	0.138
8.8	0.003	0.141
8.9	0.003	0.144

Time (0.1 hours)	Incremental Rainfall	Cumulative Rainfall
9.0	0.003	0.147
9.1	0.003	0.150
9.2	0.003	0.153
9.3	0.004	0.157
9.4	0.003	0.160
9.5	0.003	0.163
9.6	0.003	0.166
9.7	0.004	0.170
9.8	0.003	0.173
9.9	0.004	0.177
10.0	0.004	0.181
10.1	0.004	0.185
10.2	0.004	0.189
10.3	0.005	0.194
10.4	0.005	0.199
10.5	0.005	0.204
10.6	0.005	0.209
10.7	0.006	0.215
10.8	0.006	0.221
10.9	0.007	0.228
11.0	0.007	0.235
11.1	0.008	0.243
11.2	0.008	0.251
11.3	0.010	0.261
11.4	0.010	0.271
11.5	0.012	0.283
11.6	0.024	0.307
11.7	0.047	0.354
11.8	0.077	0.431
11.9	0.137	0.568
12.0	0.095	0.663
12.1	0.019	0.682
12.2	0.017	0.699
12.3	0.014	0.713
12.4	0.012	0.725
12.5	0.010	0.735
12.6	0.008	0.743
12.7	0.008	0.751
12.8	0.008	0.759
12.9	0.007	0.766
13.0	0.006	0.772
13.1	0.006	0.778
13.2	0.006	0.784
13.3	0.005	0.789
13.4	0.005	0.794

Table 4C-4. SCS Type II storm hyetograph values (continued).

Time (0.1 hours)	Incremental Rainfall	Cumulative Rainfall
13.5	0.005	0.799
13.6	0.005	0.804
13.7	0.004	0.808
13.8	0.004	0.812
13.9	0.004	0.816
14.0	0.004	0.820
14.1	0.004	0.824
14.2	0.003	0.827
14.3	0.004	0.831
14.4	0.003	0.834
14.5	0.004	0.838
14.6	0.003	0.841
14.7	0.003	0.844
14.8	0.003	0.847
14.9	0.003	0.850
15.0	0.004	0.854
15.1	0.002	0.856
15.2	0.003	0.859
15.3	0.003	0.862
15.4	0.003	0.865
15.5	0.003	0.868
15.6	0.002	0.870
15.7	0.003	0.873
15.8	0.002	0.875
15.9	0.003	0.878
16.0	0.002	0.880
16.1	0.002	0.882
16.2	0.003	0.885
16.3	0.002	0.887
16.4	0.002	0.889
16.5	0.002	0.891
16.6	0.002	0.893
16.7	0.002	0.895
16.8	0.003	0.898
16.9	0.002	0.900
17.0	0.002	0.902
17.1	0.002	0.904
17.2	0.002	0.906
17.3	0.002	0.908
17.4	0.002	0.910
17.5	0.002	0.912
17.6	0.002	0.914
17.7	0.001	0.915
17.8	0.002	0.917
17.9	0.002	0.919

Time (0.1 hours)	Incremental Rainfall	Cumulative Rainfall
18.0	0.002	0.921
18.1	0.002	0.923
18.2	0.002	0.925
18.3	0.001	0.926
18.4	0.002	0.928
18.5	0.002	0.930
18.6	0.001	0.931
18.7	0.002	0.933
18.8	0.002	0.935
18.9	0.001	0.936
19.0	0.002	0.938
19.1	0.001	0.939
19.2	0.002	0.941
19.3	0.001	0.942
19.4	0.002	0.944
19.5	0.001	0.945
19.6	0.002	0.947
19.7	0.001	0.948
19.8	0.001	0.949
19.9	0.002	0.951
20.0	0.001	0.952
20.1	0.001	0.953
20.2	0.002	0.955
20.3	0.001	0.956
20.4	0.001	0.957
20.5	0.001	0.958
20.6	0.002	0.960
20.7	0.001	0.961
20.8	0.001	0.962
20.9	0.002	0.964
21.0	0.001	0.965
21.1	0.001	0.966
21.2	0.001	0.967
21.3	0.001	0.968
21.4	0.002	0.970
21.5	0.001	0.971
21.6	0.001	0.972
21.7	0.001	0.973
21.8	0.002	0.975
21.9	0.001	0.976
22.0	0.001	0.977
22.1	0.001	0.978
22.2	0.001	0.979
22.3	0.002	0.981
22.4	0.001	0.982

Time (0.1 hours)	Incremental Rainfall	Cumulative Rainfall
22.5	0.001	0.983
22.6	0.001	0.984
22.7	0.001	0.985
22.8	0.001	0.986
22.9	0.002	0.988
23.0	0.001	0.989
23.1	0.001	0.990
23.2	0.001	0.991
23.3	0.001	0.992
23.4	0.001	0.993
23.5	0.001	0.994
23.6	0.002	0.996
23.7	0.001	0.997
23.8	0.001	0.998
23.9	0.001	0.999
24.0	0.001	1.000

Table 4C-5. Short-duration storm hyetograph values: All regions.

Use 2-hour precipitation value times 1.06 to determine 3-hour total precipitation amount.

Time (minutes)	Time (hours)	Incremental Rainfall	Cumulative Rainfall
0	0	0.0000	0.0000
5	0.08	0.0047	0.0047
10	0.17	0.0047	0.0094
15	0.25	0.0057	0.0151
20	0.33	0.0104	0.0255
25	0.42	0.0123	0.0378
30	0.50	0.0236	0.0614
35	0.58	0.0292	0.0906
40	0.67	0.0528	0.1434
45	0.75	0.0736	0.2170
50	0.83	0.1736	0.3906
55	0.92	0.2377	0.6283
60	1.00	0.1255	0.7538
65	1.08	0.0604	0.8142
70	1.17	0.0406	0.8548
75	1.25	0.0151	0.8699
80	1.33	0.0132	0.8831
85	1.42	0.0113	0.8944
90	1.50	0.0104	0.9048
95	1.58	0.0085	0.9133
100	1.67	0.0075	0.9208
105	1.75	0.0057	0.9265
110	1.83	0.0057	0.9322
115	1.92	0.0057	0.9379
120	2.00	0.0057	0.9436
125	2.08	0.0047	0.9483
130	2.17	0.0047	0.9530
135	2.25	0.0047	0.9577
140	2.33	0.0047	0.9624
145	2.42	0.0047	0.9671
150	2.50	0.0047	0.9718
155	2.58	0.0047	0.9765
160	2.67	0.0047	0.9812
165	2.75	0.0047	0.9859
170	2.83	0.0047	0.9906
175	2.92	0.0047	0.9953
180	3.00	0.0047	1.0000

Table 4C-6. Long-duration storm hyetograph values: Region 1 – Cascade Mountains.

Use 24-hour precipitation value times 1.16 to determine long-duration storm precipitation total.

Time (hours)	Incremental Rainfall	Cumulative Rainfall
0.0	0.0000	0.0000
0.5	0.0024	0.0024
1.0	0.0036	0.0060
1.5	0.0040	0.0101
2.0	0.0047	0.0148
2.5	0.0051	0.0199
3.0	0.0054	0.0253
3.5	0.0058	0.0311
4.0	0.0062	0.0374
4.5	0.0066	0.0439
5.0	0.0078	0.0517
5.5	0.0096	0.0614
6.0	0.0120	0.0733
6.5	0.0138	0.0871
7.0	0.0150	0.1022
7.5	0.0157	0.1179
8.0	0.0164	0.1343
8.5	0.0171	0.1513
9.0	0.0178	0.1691
9.5	0.0185	0.1876
10.0	0.0192	0.2067
10.5	0.0198	0.2266
11.0	0.0205	0.2471
11.5	0.0212	0.2683
12.0	0.0220	0.2904
12.5	0.0226	0.3130
13.0	0.0235	0.3364
13.5	0.0243	0.3608

Time (hours)	Incremental Rainfall	Cumulative Rainfall
14.0	0.0297	0.3905
14.5	0.0338	0.4243
15.0	0.0507	0.4750
15.5	0.0315	0.5066
16.0	0.0283	0.5349
16.5	0.0257	0.5606
17.0	0.0231	0.5837
17.5	0.0214	0.6051
18.0	0.0183	0.6234
18.5	0.0168	0.6402
19.0	0.0165	0.6566
19.5	0.0161	0.6728
20.0	0.0158	0.6886
20.5	0.0154	0.7040
21.0	0.0151	0.7191
21.5	0.0148	0.7339
22.0	0.0144	0.7483
22.5	0.0141	0.7623
23.0	0.0137	0.7761
23.5	0.0134	0.7894
24.0	0.0130	0.8025
24.5	0.0127	0.8151
25.0	0.0123	0.8275
25.5	0.0120	0.8395
26.0	0.0117	0.8512
26.5	0.0115	0.8627
27.0	0.0112	0.8739
27.5	0.0110	0.8849

Time (hours)	Incremental Rainfall	Cumulative Rainfall
28.0	0.0107	0.8956
28.5	0.0104	0.9060
29.0	0.0102	0.9162
29.5	0.0099	0.9261
30.0	0.0097	0.9358
30.5	0.0088	0.9446
31.0	0.0079	0.9525
31.5	0.0071	0.9596
32.0	0.0063	0.9659
32.5	0.0058	0.9717
33.0	0.0054	0.9772
33.5	0.0050	0.9822
34.0	0.0047	0.9869
34.5	0.0043	0.9912
35.0	0.0039	0.9950
35.5	0.0030	0.9981
36.0	0.0019	1.0000

Table 4C-7. Long-duration storm hyetograph values: Region 2 – Central Basin.

Use 24-hour precipitation value times 1.00 to determine long-duration storm precipitation total.

Time (hours)	Incremental Rainfall	Cumulative Rainfall
0.0	0.0000	0.0000
0.5	0.0054	0.0054
1.0	0.0086	0.0140
1.5	0.0100	0.0240
2.0	0.0120	0.0360
2.5	0.0130	0.0490
3.0	0.0140	0.0630
3.5	0.0150	0.0780
4.0	0.0160	0.0940
4.5	0.0170	0.1110
5.0	0.0187	0.1297
5.5	0.0228	0.1525
6.0	0.0283	0.1808
6.5	0.0305	0.2113
7.0	0.0335	0.2448
7.5	0.0365	0.2813
8.0	0.0484	0.3297
8.5	0.0622	0.3919

Time (hours)	Incremental Rainfall	Cumulative Rainfall
9.0	0.0933	0.4852
9.5	0.0527	0.5380
10.0	0.0402	0.5782
10.5	0.0372	0.6154
11.0	0.0348	0.6502
11.5	0.0331	0.6833
12.0	0.0289	0.7122
12.5	0.0252	0.7374
13.0	0.0219	0.7593
13.5	0.0191	0.7783
14.0	0.0167	0.7950
14.5	0.0148	0.8098
15.0	0.0134	0.8232
15.5	0.0123	0.8355
16.0	0.0116	0.8471
16.5	0.0110	0.8581
17.0	0.0105	0.8686
17.5	0.0103	0.8789

Time (hours)	Incremental Rainfall	Cumulative Rainfall
18.0	0.0103	0.8892
18.5	0.0104	0.8996
19.0	0.0105	0.9100
19.5	0.0105	0.9205
20.0	0.0104	0.9309
20.5	0.0102	0.9412
21.0	0.0100	0.9512
21.5	0.0097	0.9609
22.0	0.0093	0.9702
22.5	0.0087	0.9789
23.0	0.0083	0.9872
23.5	0.0078	0.9950
24.0	0.0050	1.0000

Table 4C-8. Long-duration storm hyetograph values: Region 3 – Okanogan, Spokane, Palouse.

Use 24-hour precipitation value times 1.06 to determine long-duration storm precipitation total.

Time (hours)	Incremental Rainfall	Cumulative Rainfall
0.0	0.0000	0.0000
0.5	0.0017	0.0017
1.0	0.0030	0.0047
1.5	0.0041	0.0088
2.0	0.0053	0.0141
2.5	0.0068	0.0209
3.0	0.0092	0.0301
3.5	0.0108	0.0409
4.0	0.0126	0.0535
4.5	0.0132	0.0667
5.0	0.0139	0.0806
5.5	0.0147	0.0952
6.0	0.0154	0.1106
6.5	0.0162	0.1268
7.0	0.0169	0.1437
7.5	0.0177	0.1614
8.0	0.0184	0.1798
8.5	0.0192	0.1990
9.0	0.0228	0.2219
9.5	0.0238	0.2457
10.0	0.0260	0.2717
10.5	0.0282	0.2999
11.0	0.0395	0.3394
11.5	0.0564	0.3958
12.0	0.0855	0.4813
12.5	0.0451	0.5265
13.0	0.0348	0.5612
13.5	0.0335	0.5948
14.0	0.0276	0.6223
14.5	0.0199	0.6422
15.0	0.0179	0.6601
15.5	0.0158	0.6759
16.0	0.0156	0.6915
16.5	0.0154	0.7069
17.0	0.0152	0.7221
17.5	0.0150	0.7372
18.0	0.0148	0.7519
18.5	0.0145	0.7664
19.0	0.0142	0.7806
19.5	0.0139	0.7945
20.0	0.0136	0.8081
20.5	0.0133	0.8215

Time (hours)	Incremental Rainfall	Cumulative Rainfall
21.0	0.0131	0.8346
21.5	0.0130	0.8475
22.0	0.0128	0.8603
22.5	0.0126	0.8729
23.0	0.0123	0.8852
23.5	0.0120	0.8972
24.0	0.0116	0.9088
24.5	0.0112	0.9200
25.0	0.0108	0.9308
25.5	0.0104	0.9412
26.0	0.0100	0.9512
26.5	0.0096	0.9607
27.0	0.0092	0.9699
27.5	0.0086	0.9785
28.0	0.0074	0.9859
28.5	0.0054	0.9913
29.0	0.0040	0.9953
29.5	0.0030	0.9983
30.0	0.0017	1.0000

Table 4C-9. Long-duration storm hyetograph values: Region 4 – Northeastern Mountains and Blue Mountains.

Use 24-hour precipitation value times 1.07 to determine long-duration storm precipitation total.

Time (hours)	Incremental Rainfall	Cumulative Rainfall
0.0	0.0000	0.0000
0.5	0.0015	0.0015
1.0	0.0031	0.0046
1.5	0.0047	0.0094
2.0	0.0064	0.0158
2.5	0.0082	0.0239
3.0	0.0104	0.0343
3.5	0.0115	0.0458
4.0	0.0123	0.0581
4.5	0.0130	0.0711
5.0	0.0137	0.0848
5.5	0.0145	0.0993
6.0	0.0152	0.1145
6.5	0.0160	0.1305
7.0	0.0167	0.1472
7.5	0.0174	0.1646
8.0	0.0182	0.1828
8.5	0.0190	0.2019
9.0	0.0207	0.2226
9.5	0.0232	0.2458
10.0	0.0260	0.2717
10.5	0.0278	0.2996
11.0	0.0399	0.3394
11.5	0.0531	0.3925
12.0	0.0796	0.4722
12.5	0.0441	0.5162
13.0	0.0329	0.5492
13.5	0.0303	0.5795
14.0	0.0291	0.6086
14.5	0.0199	0.6284
15.0	0.0166	0.6451
15.5	0.0155	0.6606
16.0	0.0153	0.6759
16.5	0.0151	0.6910
17.0	0.0149	0.7059
17.5	0.0148	0.7207
18.0	0.0146	0.7353
18.5	0.0144	0.7496
19.0	0.0142	0.7639
19.5	0.0140	0.7779
20.0	0.0137	0.7915
20.5	0.0134	0.8049

Time (hours)	Incremental Rainfall	Cumulative Rainfall
21.0	0.0132	0.8181
21.5	0.0131	0.8312
22.0	0.0129	0.8441
22.5	0.0129	0.8570
23.0	0.0128	0.8697
23.5	0.0127	0.8825
24.0	0.0127	0.8951
24.5	0.0126	0.9077
25.0	0.0124	0.9201
25.5	0.0121	0.9322
26.0	0.0116	0.9438
26.5	0.0109	0.9547
27.0	0.0101	0.9647
27.5	0.0090	0.9738
28.0	0.0077	0.9814
28.5	0.0061	0.9875
29.0	0.0051	0.9926
29.5	0.0045	0.9971
30.0	0.0029	1.0000

4C-6 Precipitation Magnitude for 24-Hour and Long- and Short-Duration Runoff Treatment Storm

The frequency of the long-duration runoff treatment storm is a 6-month recurrence interval or twice per year return period. Unfortunately, the NOAA Atlas 2 maps require the conversion of 2-year, 24-hour precipitation to 6-month, 24-hour precipitation.

The following equation is used to determine the 6-month precipitation:

$$P_{wqs} = C_{wqs} (P_{2yr24hr})$$

where: P_{wqs} is the 24-hour precipitation (inches) for the storm recurrence interval of 6 months; this precipitation is used with the long-duration storm hyetograph or 24-hour SCS (NRCS) Type IA or Type II hyetographs, depending on the design storm option selected by the jurisdiction;

C_{wqs} is a coefficient from Table 4C-10 for computing the 6-month, 24-hour precipitation based on the climatic region; and

$P_{2yr24hr}$ is the 2-year, 24-hour precipitation in Appendix 4A.

Values of the coefficient C_{wqs} are shown in Table 4C-10 for all four regions.

Table 4C-10. Coefficients C_{wqs} for computing 6-month, 24-hour precipitation.

Region #	Region Name	C_{wqs}
1	East Slope Cascades	0.70
2	Central Basin	0.66
3	Okanogan, Spokane, Palouse	0.69
4	NE & Blue Mountains	0.70

4C-7 Precipitation Magnitude for Long-Duration Storms

Table 4C-11 provides the multipliers, by region, for the conversion of the 24-hour precipitation to the regional long-duration storm precipitation. Using the precipitation values from the isopluvial maps and the conversion factor in Table 4C-11, the precipitation can be adjusted for the long-duration hyetograph. The design of volume-based BMPs requires the regional long-duration storm in Regions 1 and 4. For Regions 2 and 4, designers can choose either the SCS Type 1A storm distribution or the regional long-duration storm. When the Type 1A storm distribution is used, the conversion factors in Table 4C-11 do not apply.

Table 4C-11. Conversion factor for 24-hour to regional long-duration storm precipitation.

Region #	Region Name	Conversion Factor
1	East Slope Cascades	1.16
2	Central Basin	1.00
3	Okanogan, Spokane, Palouse	1.06
4	NE & Blue Mountains	1.07

The following equation is used to determine the long-duration precipitation for a selected return period:

$$P_{sds} = C_F (P_{N\text{-yr } 24\text{-hr}})$$

where: P_{sds} is the precipitation (inches) adjusted for a selected long-duration hyetograph;

C_F is a conversion factor from Table 4C-11, by region, for converting the 24-hour precipitation to the regional long-duration storm precipitation; and

$P_{N\text{-yr } 24\text{-hr}}$ is the precipitation from the isopluvial maps for N years and 24 hours, Appendix 4A.

4C-7.1 Precipitation Magnitude for Short-Duration Storms

The only mapped frequency of the short-duration storm is a 2-year, 2-hour recurrence interval. The design of flow-based treatment BMPs using the Single Event Hydrograph Model requires conversion of the 2-year, 2-hour precipitation to the 6-month, 2-hour precipitation. The design of other BMPs or conveyance elements based on the short-duration storm could also require the conversion of the 2-year, 2-hour precipitation to a different recurrence interval.

The following equation is used to determine the 3-hour precipitation for a selected return period:

$$P_{sds} = C_{sds} (P_{2\text{yr}2\text{hr}})$$

where: P_{sds} is the 3-hour precipitation (inches) for a selected return period for the short-duration storm;

C_{sds} is a coefficient from Table 4C-12 for computing the 2-hour precipitation for a selected return period based on the 2-year, 2-hour precipitation; and

$P_{2\text{yr}2\text{hr}}$ is the 2-year, 2-hour precipitation in Appendix 4A.

Values of the coefficient C_{sds} are based on the Generalized Extreme Value (GEV) distribution, whose distribution parameters can be expressed as a function of mean annual

precipitation for eastern Washington. Table 4C-12 lists values of the coefficient C_{sds} for selected return periods for various magnitudes of mean annual precipitation. The web link for an isopluvial map of mean annual precipitation is in Appendix 4A (the map can be used to determine the mean annual precipitation for the site).

Table 4C-12. Precipitation for selected return periods (C_{sds}).

Region #	Mean Annual Precipitation (in.)	6-Month	1-Year	2-Year	10-Year	25-Year	50-Year	100-Year
2	6-8	0.65	0.84	1.06	1.73	2.30	2.84	3.49
	8-10	0.66	0.85	1.06	1.70	2.22	2.70	3.28
	10-12	0.68	0.86	1.06	1.65	2.14	2.59	3.10
2, 3	12-16	0.70	0.87	1.06	1.60	2.01	2.40	2.82
3	16-22	0.71	0.88	1.06	1.56	1.93	2.26	2.63
1, 4	22-28	0.73	0.89	1.06	1.52	1.84	2.13	2.45
	28-40	0.74	0.90	1.06	1.48	1.78	2.04	2.32
	40-60	0.76	0.91	1.06	1.44	1.71	1.93	2.17
	60-120	0.78	0.92	1.06	1.41	1.64	1.84	2.05

Stormwater Best Management Practices

Chapter 5. Table of Contents

Chapter 5.	Stormwater Best Management Practices	5-1
5-1	Introduction	5-1
5-2	Types and Functions of Permanent Stormwater BMPs.....	5-2
5-2.1	BMPs for Stormwater Source Control	5-2
5-2.2	BMPs for Stormwater Runoff Treatment.....	5-3
5-2.2.1	Infiltration BMPs	5-4
5-2.2.2	Dispersion BMPs.....	5-4
5-2.2.3	Biofiltration BMPs	5-5
5-2.2.4	Wet Pool BMPs	5-7
5-2.2.5	Oil Control BMPs.....	5-8
5-2.2.6	Phosphorous Control BMPs	5-8
5-2.3	BMPs for Stormwater Flow Control.....	5-8
5-2.3.1	Infiltration BMPs.....	5-8
5-2.3.2	Dispersion BMPs.....	5-9
5-2.3.3	Detention BMPs	5-10
5-3	BMP Selection Process	5-10
5-3.1	Part I: Determine the Applicable Minimum Requirements and Project-Specific Considerations.....	5-10
5-3.2	Part II: Select Source Control BMPs	5-11
5-3.3	Part III: Select Flow Control BMPs.....	5-11
5-3.4	Part IV: Select Runoff Treatment BMPs	5-14
5-3.5	Seeking Authorization for Alternative BMP Options.....	5-17
5-3.5.1	Category 1: Ecology-Approved BMPs Not in the HRM.....	5-18
5-3.5.2	Category 2: Emerging Technologies	5-18
5-3.5.3	Category 3: The Demonstrative Approach.....	5-22
5-3.6	BMP Validation and Cost-Effectiveness	5-23
5-3.6.1	General Maintenance Requirements.....	5-23
5-4	BMP Design Criteria.....	5-29
5-4.1	Runoff Treatment Methods.....	5-29
5-4.1.1	Infiltration BMPs.....	5-30
5-4.1.2	Dispersion BMPs.....	5-30
5-4.1.3	Biofiltration BMPs	5-30
	RT.02 – Vegetated Filter Strip.....	5-30
	RT.04 – Biofiltration Swale.....	5-41
	RT.05 – Wet Biofiltration Swale.....	5-57
	RT.06 – Continuous Inflow Biofiltration Swale.....	5-61
	RT.07 – Media Filter Drain (previously referred to as the Ecology Embankment).....	5-65
5-4.1.4	Wet Pool BMPs	5-77
	RT.12 – Wet Pond	5-77
	CO.01 – Combined Wet/Detention Pond	5-88

RT.13 – Constructed Stormwater Treatment Wetland	5-94
CO.02 – Combined Stormwater Treatment Wetland/Detention Pond ...	5-105
5-4.1.5 Oil Control BMPs	5-107
RT.22 – Oil Containment Boom.....	5-107
5-4.2 Flow Control Methods	5-109
5-4.2.1 Infiltration BMPs.....	5-109
IN.01 – Bioinfiltration Pond (eastern Washington only).....	5-109
IN.02 – Infiltration Pond.....	5-114
IN.03 – Infiltration Trench	5-120
IN.04 – Infiltration Vault.....	5-130
IN.05 – Drywell	5-134
IN.06 – Permeable Pavement Surfaces.....	5-137
5-4.2.2 Dispersion BMPs.....	5-149
FC.01 – Natural Dispersion	5-149
FC.02 – Engineered Dispersion.....	5-159
5-4.2.3 Detention BMPs	5-168
FC.03 – Detention Pond	5-168
5-4.3 Stormwater Facility Components.....	5-181
5-4.3.1 Pretreatment.....	5-181
RT.24 – Presettling/Sedimentation Basin.....	5-181
5-4.3.2 Soil Amendments	5-186
5-4.3.3 Facility Liners.....	5-193
5-4.3.4 Flow Splitters.....	5-197
5-4.3.5 Flow Spreading Options	5-201
5-4.3.6 Outfall Systems.....	5-206
5-5 Operation and Maintenance.....	5-217
5-5.1 Typical BMP Maintenance Standards.....	5-217
5-5.2 Natural and Landscaped Areas Designated as Stormwater Management Facilities	5-217
5-5.2.1 Documenting and Preserving Intended Functions.....	5-231
5-5.2.2 Sensitive Area Mapping	5-231
5-5.2.3 Stormwater Inventory	5-231
5-6 References	5-232

List of Tables

Table 5.3.1.	Relative rankings of cost elements and effective life of BMP options.	5-24
Table RT.02.1.	Surface roughness/Manning's n for vegetated filter strip design calculations.	5-36
Table RT.04.1.	Flow resistance coefficient in basic, wet, and continuous inflow biofiltration swales.	5-45
Table RT.04.2.	Biofiltration swale sizing criteria.	5-45
Table RT.05.1.	Recommended plants for wet biofiltration swales in western Washington. ...	5-61
Table RT.07.1.	Western Washington design widths for media filter drains.	5-74
Table RT.07.2.	Media filter drain mix.	5-75
Table RT.12.1.	Emergent wetland plant species recommended for wet ponds.	5-86
Table RT.13.1.	Distribution of depths in wetland cell.	5-96
Table RT.13.2.	Plant species recommended for stormwater treatment wetlands in western Washington.	5-100
Table CO.02.1.	Wetland plants adapted to water level fluctuations.	5-106
Table IN.06.1.	Permeable surface application matrix.	5-142
Table 5.4.1.	Lining types recommended for runoff treatment facilities.	5-194
Table 5.4.2.	Compacted till liner gradation requirements.	5-196
Table 5.4.3.	Rock protection at outfalls.	5-209
Table 5.5.1.	Maintenance standards for detention ponds.	5-218
Table 5.5.2.	Maintenance standards for bioinfiltration ponds/infiltration trenches/basins.	5-220
Table 5.5.3.	Maintenance standards for closed treatment systems (tanks/vaults).	5-221
Table 5.5.4.	Maintenance standards for control structure/flow restrictor.	5-222
Table 5.5.5.	Maintenance standards for catch basins.	5-223
Table 5.5.6.	Maintenance standards for debris barriers (such as trash racks).	5-224
Table 5.5.7.	Maintenance standards for energy dissipaters.	5-225
Table 5.5.8.	Maintenance standards for biofiltration swale.	5-226
Table 5.5.9.	Maintenance standards for vegetated filter strip.	5-227
Table 5.5.10.	Maintenance standards for media filter drain.	5-227

Table 5.5.11.	Maintenance standards for permeable pavement.	5-228
Table 5.5.12.	Maintenance standards for dispersion areas (natural and engineered).	5-229
Table 5.5.13.	Maintenance standards for wet ponds.	5-230

List of Figures

Figure 5.3.1	Flow control BMP selection flow chart.	5-12
Figure 5.3.2	Runoff treatment BMP selection flow chart.	5-15
Figure 5.3.6.1.	Process for using BMPs not in the HRM.	5-20
Figure RT.02.1.	Typical vegetated filter strip.	5-31
Figure RT.02.2.	Narrow area vegetated filter strip design graph.	5-40
Figure RT.04.1.	Biofiltration swale: Plan view.	5-42
Figure RT.04.2.	Biofiltration swale: Cross section.	5-43
Figure RT.04.3.	Biofiltration swale: Underdrain detail.	5-46
Figure RT.04.4.	Biofiltration swale: Low-flow drain detail.	5-47
Figure RT.04.5.	Geometric elements of common cross sections.	5-50
Figure RT.04.6.	Open channel flow parameter, $Qn/(1.49 s^{0.5})$, versus bottom width (b) at different flow depths ($z = 3$).	5-51
Figure RT.04.7.	Open channel flow parameter, $Qn/(1.49 s^{0.5})$, versus bottom width (b) at different flow depths ($z = 4$).	5-52
Figure RT.07.1	Media filter drain: Cross section.	5-66
Figure RT.07.2	Dual Media filter drain: Cross section.	5-67
Figure RT.07.3	Media filter drain without underdrain trench.	5-68
Figure RT.05.1.	Wet biofiltration swale: Cross section.	5-60
Figure RT.06.1.	Continuous inflow biofiltration swale: Plan view.	5-62
Figure RT.12.1.	Wet pond: Plan view.	5-78
Figure RT.12.2.	Wet pond: Cross section.	5-79
Figure CO.01.1.	Combined detention and wet pond: Plan view.	5-90
Figure CO.01.2.	Combined detention and wet pond: Cross sections.	5-91
Figure CO.01.3.	Alternative configurations of detention and wet pond areas.	5-93
Figure RT.13.1.	Constructed wetlands for stormwater treatment.	5-97

Figure RT.22.1.	Oil containment boom.....	5-108
Figure IN.01.1.	Bioinfiltration pond.....	5-112
Figure IN.02.1.	Infiltration pond.....	5-115
Figure IN.03.1.	Parking lot perimeter trench design.....	5-121
Figure IN.03.2.	Infiltration trench system.....	5-122
Figure IN.03.3.	Median strip trench design.....	5-123
Figure IN.03.4.	Oversize pipe trench design.....	5-124
Figure IN.03.5.	Underground trench and oil/grit chamber.....	5-125
Figure IN.03.6.	Observation well detail.....	5-128
Figure IN.04.1.	Infiltration vault constructed with corrugated pipe.....	5-132
Figure IN.06.1.	Permeable pavement surface detail.....	5-145
Figure FC.01.1.	Natural dispersion area.....	5-155
Figure FC.02.1.	Engineered dispersion area.....	5-163
Figure FC.03.1.	Detention pond.....	5-169
Figure FC.03.2.	Detention pond: Cross sections.....	5-170
Figure FC.03.3.	Detention pond: Cross sections.....	5-171
Figure FC.03.4.	Overflow structure with debris cage.....	5-174
Figure FC.03.5.	Overflow sizing structure.....	5-175
Figure RT.24.1.	Typical presettling/sedimentation basin.....	5-182
Figure RT.24.2.	Presettling/sedimentation basin: Alternate sections.....	5-183
Figure 5.4.3.1.	Soil amendments for vegetation.....	5-190
Figure 5.4.3.2.	Flow splitter: Option A.....	5-199
Figure 5.4.3.3.	Flow splitter: Option B.....	5-200
Figure 5.4.3.4.	Flow spreader Option A: Anchor plate.....	5-203
Figure 5.4.3.5.	Flow spreader Option B: Concrete sump box.....	5-204
Figure 5.4.3.6.	Flow spreader Option C: Notched curb spreader.....	5-205
Figure 5.4.3.7.	Flow spreader Option D: Through-curb port.....	5-206
Figure 5.4.3.8.	Pipe/culvert outfall discharge.....	5-208
Figure 5.4.3.9.	Flow dispersal trench.....	5-210
Figure 5.4.3.10.	Alternative flow dispersal trench.....	5-211

Figure 5.4.3.11. Gabion outfall detail5-212

Figure 5.4.3.12. Diffuser tee: Example of energy-dissipating end feature.5-213

Figure 5.4.3.13. Fish habitat improvement at new outfalls.....5-215

Chapter 5. Stormwater Best Management Practices

5-1 Introduction

The intent of this chapter is to provide designers of Washington State Department of Transportation (WSDOT) facilities with specific guidelines and criteria on the proper selection, design, and application of stormwater management techniques. A selection process is presented, along with design considerations for each best management practice (BMP). This chapter also presents ways to combine or enhance the different types of facilities to maximize their efficiency or to better fit within the project site.

Stormwater BMPs are the *physical, structural, and managerial* practices that, when used singly or in combination, prevent or reduce the detrimental impacts of stormwater, such as the pollution of water, degradation of channels, damage to structures, and flooding. These BMPs can be further characterized as performing the following three essential, yet distinct, functions:

- **Source control:** Prevents or reduces the introduction of pollutants to stormwater.
- **Flow control:** Offsets and attenuates the increased rate of discharge caused by impervious surfaces.
- **Runoff treatment:** Intercepts and reduces the physical, chemical, and biological pollutant loads generated primarily from highway use.

The typical pollutants found in highway runoff that must be considered for treatment include total suspended solids (TSS) and sediments; dissolved metals (such as cadmium, copper, zinc, and lead); polycyclic aromatic hydrocarbons (PAHs); oil and grease; road salts and deicing agents; temperature; and, in some watersheds, nutrients (such as nitrogen and phosphorus).

The BMPs in this manual have been developed using the best available science, and they have been approved by the Washington State Department of Ecology (Ecology). The required application of these BMPs is based on the state-adopted standard of using all known, available, and reasonable technologies (AKART) and methods of prevention, control, and treatment. When used and maintained in conjunction with operational source controls, BMPs can provide a long-term, effective means of preventing violations of water quality standards. However, it is essential that utmost care be taken in the proper selection and site application of the various BMPs for every project to ensure the maximum benefit is obtained.

Many of the BMPs covered in this manual include general recommendations regarding the conditions under which a practice applies, as well as the advantages and disadvantages of that practice. However, it is strongly recommended that designers take an iterative approach to selecting BMPs based on site-specific criteria. This entails being flexible and somewhat

creative when determining a final stormwater management solution that works best in each situation. It also requires that stormwater management considerations be wholly integrated throughout the entire project development decision-making process (see Chapter 2 for further guidelines).

Design guidelines for most of the commonly used permanent BMPs for highway applications can be found in Section 5.4. Guidelines for the design of temporary BMPs used during construction are given in Appendix 6A. For guidelines and criteria on the design of source control BMPs, refer to Volume IV of Ecology's *Stormwater Management Manual for Western Washington* (SMMWW) and Chapter 8 of the *Stormwater Management Manual for Eastern Washington* (SMMEW). For guidelines and criteria on the design and application of temporary spill prevention and containment BMPs during construction, see Section 6-3.

5-2 Types and Functions of Permanent Stormwater BMPs

This section of the manual provides a general overview of the currently available BMPs and the circumstances under which they are typically used. Specific design criteria for each BMP can be found in Section 5-4.

Permanent stormwater BMPs are management features that are designed into a project and remain in place throughout the service life of the project. The designer must make sure that the BMPs will provide the desired results and can be maintained within the guidelines established in Section 5-5. The project should be designed to take advantage of the topography, soils, waterways, and natural vegetation at the site. At each stage of the design, the designer should evaluate the potential for stormwater degradation and choose the design with the least impact. The designer must plan the project so construction activities will not generate excessive sediment and runoff leaving the site. Finally, the project must be designed so that stormwater facilities are reasonably accessible to perform the required maintenance.

5-2.1 BMPs for Stormwater Source Control

The first consideration in design should be *source control*. Stormwater source controls are designed to prevent pollutants from entering stormwater by eliminating the source of pollution or by preventing the contact of pollutants with rainfall and runoff. Source control BMPs must be applied to the entire project, both existing and new project areas. According to Volume IV, Chapter 2, of the SMMWW and Chapter 8 of the SMMEW, source control BMPs apply to the following WSDOT activities or settings:

- Deicing and anti-icing for streets and highways
- Dust control at disturbed land areas and unpaved roadways and parking lots
- Fueling at dedicated stations

- Illicit connections to storm drains (that is, unpermitted sanitary or process water discharges to a storm drain rather than a sanitary sewer connection)
- Landscaping and lawn/vegetation management
- Maintenance and repair of vehicles and equipment
- Maintenance of roadside ditches
- Maintenance of stormwater drainage and treatment systems
- Painting of buildings and structures (bridges and docks)
- Parking and storage of vehicles and equipment
- Railroad yards
- Spills of oil and hazardous substances
- Storage or transfer (outside) of solid raw materials, byproducts, or finished products
- Urban streets
- Washing and steam cleaning of vehicles, equipment, and building structures

Only a few permanent source control BMPs (such as street sweeping, deicing, and spill control) can be regularly used for a roadway. Source control BMPs are used more commonly during construction and for the permanent portion of nonroadway projects such as rest areas and park-and-ride lots. The source control BMPs for use during construction are detailed in Chapter 6. The designer should refer to Volume IV of the SMMWW and Chapter 8 of the SMMEW for guidelines on selecting proper source control BMPs for permanent facilities. Contact the Environmental Services Office, Hazardous Materials and Solid Waste, for further assistance when a project involves the storage or transfer of hazardous materials or waste products.

5-2.2 BMPs for Stormwater Runoff Treatment

Runoff treatment BMPs designed to remove pollutants contained in runoff use a variety of mechanisms, including sedimentation, filtration, plant uptake, ion exchange, adsorption, precipitation, and bacterial decomposition.

Hydrologic criteria and analysis methods for sizing runoff treatment BMPs in western Washington are discussed in Section 4-3. Hydrologic criteria and analysis methods for sizing runoff treatment BMPs in eastern Washington are discussed in Section 4-4. The following overview provides information on the most commonly used runoff treatment BMPs available for highway application.

5-2.2.1 Infiltration BMPs

Infiltration BMPs for runoff treatment are discussed in Section 5-4.1.1 and include the following:

- IN.01 – Bioinfiltration Pond
- IN.02 – Infiltration Pond
- IN.03 – Infiltration Trench
- IN.04 – Infiltration Vault
- IN.05 – Drywell

In addition to being the preferred method for flow control, infiltration is a preferred method for runoff treatment, offering the highest level of pollutant removal. Treatment is achieved through settling, biological action, and filtration. One important advantage to using infiltration is that it recharges the groundwater, thereby helping to maintain summertime base flows of streams. Infiltration also produces a natural reduction in stream temperature, which is an important factor in maintaining a healthy habitat for resident species and other in-stream biota.

Infiltration facilities must be preceded by a presettling basin for removing most of the sediment particles that would otherwise reduce the infiltrative capacity of the soil. Infiltration strategies intended to meet runoff treatment goals may be challenging for many project locations in western Washington due to the large space requirements and strict soil and water table requirements (see Sections 5-4.1.1 and 5-4.2.1 for site restrictions). There are generally more opportunities for the use of infiltration BMPs in eastern Washington.

5-2.2.2 Dispersion BMPs

Dispersion BMPs are discussed in Section 5-4.1.2 and include the following:

- FC.01 – Natural Dispersion
- FC.02 – Engineered Dispersion

Perhaps the single most promising and effective approach to mitigating the effects of highway runoff in nonurbanized areas is to look for opportunities to use the existing natural area capacity to remove pollutants. *Natural dispersion* requires that runoff cannot become concentrated in any way as it flows into a preserved naturally vegetated area. The preserved naturally vegetated area must have topographic, soil, and vegetation characteristics that provide for the removal of pollutants. Pollutant removal typically occurs through a combined process of vegetative filtration and shallow surface infiltration.

The most notable benefits associated with natural dispersion are that it maintains and preserves the natural functions; reduces the possibility of further impacts to the adjacent natural areas associated with the construction of physical treatment facilities; and can be very

cost-effective. In most cases, this method not only meets the requirements for runoff treatment, but also provides flow attenuation. If channelized drainage features are present and close to the runoff areas requiring treatment, then other types of engineered solutions might be more appropriate.

Engineered dispersion techniques use the same removal processes as natural dispersion. For engineered dispersion, a constructed conveyance system directs concentrated runoff to the dispersion area (via storm sewer pipe, ditch, or other methods). The concentrated flow is dispersed at the end of the conveyance system to mimic sheet flow conditions into the dispersion area. Engineered dispersion techniques enhance the modified area with compost-amended soils and additional vegetation. These upgrades help ensure the dispersion area has the capacity and ability to infiltrate surface runoff.

Like any other stormwater BMP, preservation and maintenance protocols must be followed when dispersion techniques are used. Because the terrain features used to provide treatment are, for the most part, indistinguishable from other typical natural or landscaped areas, it is essential that these areas be readily identifiable so they are not altered or destroyed by general maintenance practices or future development. (See Section 5-5 for further criteria.)

5-2.2.3 Biofiltration BMPs

Biofiltration BMPs are discussed in Section 5-4.1.3 and include the following:

- RT.02 – Vegetated Filter Strip (basic, narrow area, and compost-amended or CAVFS)
- RT.04 – Biofiltration Swale
- RT.05 – Wet Biofiltration Swale
- RT.06 – Continuous Inflow Biofiltration Swale
- RT.07 – Media Filter Drain (previously referred to as the Ecology Embankment)

Runoff treatment to remove pollutants can be best accomplished before concentrating the flow. A *vegetated filter strip* provides a very efficient and cost-effective runoff treatment option. Vegetated filter strips function by slowing runoff velocities and filtering out sediment and other pollutants and by providing some infiltration into underlying soils. Vegetated filter strips consist of gradually sloping areas that run adjacent to the roadway. As highway runoff sheets off the roadway surface, it flows through the grass filter. The flow can then be intercepted by a ditch or other conveyance system and routed to a flow control BMP or outfall.

One challenge associated with vegetated filter strips is that sheet flow can sometimes be difficult to maintain. Consequently, vegetated filter strips can be short-circuited by concentrated flows, which create eroded rills or flow channels across the strips. This results in little or no treatment of stormwater runoff. Note: Vegetated filter strips are not

recommended for use in arid climates. In semiarid climates, drought-tolerant grasses should be specified.

Biofiltration swales also provide an effective means of removing conventional pollutants and offer a relatively low-cost treatment solution. A biofiltration swale consists of a flat-bottomed, shallow-sloped swale planted with grasses. The swales function by slowing runoff velocities, filtering out sediment and other pollutants, and providing some infiltration into underlying soils. Concentrated flow from the roadway section is directed to the high end of the swale. For wider swales, flow spreaders or diffusers are often incorporated into the bioswale to maintain sheet flow and to prevent the formation of small channels within the swale bottom. In addition, the swale design should be analyzed for erosion potential from larger storm events.

Biofiltration swales can also be integrated into the stormwater conveyance system. Existing roadside ditches may be good candidates for upgrading to biofiltration swales. Biofiltration swales are not recommended for use in arid climates. In semiarid climates, drought-tolerant grasses should be specified.

A *wet biofiltration swale* (a variation of a basic biofiltration swale) is for use where the longitudinal slope is slight, the water table is high, or continuous low base flow will likely result in saturated soil conditions.

Another variation of a basic biofiltration swale is the *continuous inflow biofiltration swale* for applications where water enters a biofiltration swale continuously along the side slope, rather than being concentrated at the upstream end.

A number of BMPs are available that integrate amendments into their soil composition. Soil amendments can be a variety of materials but usually consist of a 2- to 6-inch-thick blanket of compost, spread over the existing soil. They may be left as a blanket or incorporated into the soil to improve soil quality and texture, and thus improve infiltration. Soil amendments bind to dissolved metals, while biota in organic soil break down and neutralize the surface runoff pollutants. Soil amendments also have a very high capacity to hold moisture (up to 1½ times their weight) and can significantly reduce off-site flows. For more information on soil properties and composition, see Section 5-4.3.2, Soil Amendments.

The *media filter drain* is another option to provide significant pollution reduction and flow attenuation by simply modifying the effective treatment surface of the roadway prism beyond the edge of pavement. Its application is limited to highways located in relatively flat terrain, but this BMP can often be constructed with little or no additional right of way, making it a cost-effective solution to managing highway runoff.

Another similar and effective BMP using soil amendments is the *compost-amended vegetated filter strip* (CAVFS), which is a variation of the standard vegetated filter strip. This BMP incorporates compost amendments and subsurface gravel courses to augment the vegetation's basic treatment properties while also supplementing the need for a flow control system by providing a limited amount of storage.

5-2.2.4 Wet Pool BMPs

Wet pool BMPs are discussed in Section 5-4.1.4 and include the following:

- RT.12 – Wet Pond
- CO.01 – Combined Wet/Detention Pond
- RT.13 – Constructed Stormwater Treatment Wetland
- CO.02 – Combined Stormwater Treatment Wetland/Detention Pond

Wet ponds are constructed basins containing a permanent pool of water throughout the wet season. Wet ponds function by settling suspended solids. The biological action of plants and bacteria provides some additional treatment. Not only can wet ponds be designed for the treatment of conventional pollutants, they can also be modified to enhance removal of nutrients or dissolved metals. Wet ponds are usually more effective and efficient when constructed using multiple cells (a series of individual smaller basins) where coarser sediments become trapped in the first cell or forebay. Wet pond designs can also provide flow control by adding detention volume (live storage) above the dead storage. Because the function of a wet pond depends upon maintaining a permanent pool of water to provide treatment, this BMP is generally not recommended for use in arid or semiarid climates.

A wet pool BMP must be an on-line facility receiving runoff from only new impervious areas or equivalent areas. If a decision has been made to treat runoff from existing impervious surfaces per the retrofit instructions in Section 3-4, then the wet pool BMP would be an on-line facility receiving runoff from the new plus existing impervious areas or equivalent areas.

Constructed stormwater treatment wetlands can be designed for runoff treatment alone or to serve the dual function of runoff treatment and flow control. This BMP requires the collection and conveyance of stormwater to the facility inlet. Sediment and associated pollutants are removed in the first cell of these systems via settling. The processes of *settling*, *biofiltration*, *biodegradation*, and *bioaccumulation* provide additional treatment in the subsequent cell or cells. In general, constructed stormwater treatment wetlands could be incorporated into the drainage design wherever water can be collected and conveyed to a maintainable artificial basin.

Constructed stormwater treatment wetlands offer a suitable alternative to wet ponds or biofiltration swales and can also provide treatment for dissolved metals. However, designers must consider the availability of water and the water needs of plants used in the stormwater wetland. The landscape context for stormwater wetland placement must be appropriate for the creation of an artificial wetland (groundwater, soils, and surrounding vegetation). Natural wetlands cannot be used for stormwater treatment purposes. (See Section 3-3.7 for further guidelines on protecting existing wetlands.)

Very few constructed stormwater wetlands exist in Washington State. Limited information is available concerning the long-term viability of vegetation installed in these facilities and the maintenance requirements. However, constructed stormwater wetlands can be a preferred option for stormwater management relative to other surface treatment and flow control

facilities. In general, this option is a more aesthetically appealing alternative to ponds. Secondary functions include the creation of habitat for terrestrial wildlife, visual screening, and reduced obtrusiveness of drainage facilities.

5-2.2.5 Oil Control BMPs

Oil control BMPs are discussed in Sections 5-3.4, 5-4.1.3, 5-4.1.5, and 5-4.2.1 and include the following:

- RT.22 – Oil Containment Boom (high-use sites)
- IN.01 – Bioinfiltration Pond (eastern Washington high-use roadways and parking areas)
- RT.02 – Filter Strip and Compost-Amended Vegetative Filter Strip (CAVFS) (eastern Washington high-use roadway and parking areas)

5-2.2.6 Phosphorous Control BMPs

Phosphorous control BMPs are discussed in Sections 5-4.1.3 and 5-4.1.4 and include the following:

- RT.12 – Wet Pond (large)
- RT.07 – Media Filter Drain (previously referred to as the Ecology Embankment)

5-2.3 BMPs for Stormwater Flow Control

Stormwater flow control BMPs are designed to control the flow rate or the amount of runoff leaving a site after development. The primary mechanisms used to manage flow control include *dispersion*, *infiltration*, and *detention*. Increased flows can cause downstream damage due to flooding, erosion, and scour, as well as degradation of water quality and in-stream habitat because of channel and streambank erosion.

Hydrologic criteria and analysis methods for sizing flow control BMPs are discussed in Section 4-3 for western Washington and Section 4-4 for eastern Washington. The following provides an overview of the most commonly used flow control BMPs for highway application.

5-2.3.1 Infiltration BMPs

Infiltration BMPs for flow control are discussed in Section 5-4.2.1 and include the following:

- IN.01 – Bioinfiltration Pond (eastern Washington only)
- IN.02 – Infiltration Pond

- IN.03 – Infiltration Trench
- IN.04 – Infiltration Vault
- IN.05 – Drywell
- IN.06 – Permeable Pavement Surfaces

A bioinfiltration pond is categorized in this manual under infiltration BMPs for convenience and consistency. It actually functions as both a filtering BMP and an infiltration BMP and can therefore provide runoff treatment and flow control on a limited basis.

Two commonly used types of infiltration systems are *infiltration basins* and *subsurface infiltration*. An infiltration basin consists of a shallow impoundment designed to infiltrate stormwater into the soil. Subsurface infiltration may occur via an infiltration trench, vault, or drywell subject to the underground injection control (UIC) rules:

☞ www.ecy.wa.gov/programs/wq/grndwtr/uic/index.html. (See Sections 2-7.1.3 and 4-5.1 for further guidelines on wellhead protection areas.) An infiltration trench (also termed an infiltration gallery) consists of a rock-filled trench with no outlet. Typically, the trench also incorporates a large underdrain pipe to increase capacity. Runoff is then stored in the pipe and rock voids and slowly infiltrates through the bottom and sides of the trench and into the soil matrix over a couple of days. For trenches, this process is also referred to as *exfiltration*. Drywells consist of perforated manhole structures surrounded by drain rock and function similarly to trenches.

Infiltration systems are practicable only in areas where groundwater tables are sufficiently below the bottom of the facility and in highly permeable soil conditions. Infiltration systems can help recharge the groundwater, thus restoring base flows to stream systems. However, to protect the groundwater and prevent clogging of the system, stormwater runoff must first pass through some combination of pretreatment measures, such as a swale or sediment basin, before entering an infiltration system. Compared with other stormwater flow control practices, infiltration systems can be problematic due to siltation.

Subsurface infiltration systems should be considered only when room is inadequate to construct an infiltration basin. These systems are difficult to maintain and verify whether they are functioning properly.

5-2.3.2 Dispersion BMPs

Dispersion BMPs for flow control are discussed in Section 5-4.2.2 and include the following:

- FC.01 – Natural Dispersion
- FC.02 – Engineered Dispersion

For an overview of dispersion techniques, see Section 5-2.2.2.

5-2.3.3 Detention BMPs

Detention BMPs are discussed in Section 5-4.2.3 and includes the following:

- FC.03 – Detention Pond

Detention facilities generally take the form of either a pond or an underground vault or tank. They operate by providing a volume of live storage with an outlet control structure designed to release flow at a reduced rate over time. A pond can be configured as a dry pond to control flow only or combined with a wet pond to also provide runoff treatment within the same footprint.

5-3 BMP Selection Process

This section provides guidelines and criteria to the designer on the selection of permanent BMPs for WSDOT projects. BMP selection is necessary to address permanent stormwater management for a project and complete the Hydraulic Report. The following subsections outline the decision-making process for selecting BMPs for projects.

5-3.1 Part I: Determine the Applicable Minimum Requirements and Project-Specific Considerations

Read Chapter 3 to determine the applicable minimum requirements for the project. Start at Section 3-2.1 and analyze the project as a whole. Minimum requirements apply to the project based on the project size from beginning project limit to end project limit within right of way boundaries. Use Figure 3.1 and Figure 3.2 to determine which minimum requirements apply at the project level. If necessary, use Figure 3.3 to determine the applicable minimum requirement at the threshold discharge area (TDA) level. Next, go to those subsequent sections in Chapter 3 for each applicable minimum requirement and take time to thoroughly read and understand each minimum requirement.

Minimum Requirement 5 (Runoff Treatment) in Section 3-3.5 has a list of water bodies that require only basic treatment. Project TDAs that discharge to water bodies on this list must provide basic runoff treatment, but not enhanced treatment for phosphorus or dissolved metals removal. Minimum Requirement 6 (Flow Control) in Section 3-3.6 lists exempted water bodies. Project TDAs discharging to water bodies on this list do not require flow control. Section 1-1.5 points out where local stormwater requirements could supersede or supplement the guidelines provided herein. Check with a Region or Headquarters (HQ) Hydraulics Office representative when there are questions regarding local jurisdictional requirements.

The existing stormwater outfalls along the project limits should have been identified during the scoping phase of the project (see Section 2-3 for guidelines). If any existing outfalls will be retrofitted, determine the design requirements before continuing the BMP selection process. Check with a Region or HQ Hydraulics Office representative or the HQ

Environmental Services Office (ESO), Stormwater & Watersheds Program, for more information about stormwater outfalls and the necessary design requirements.

5-3.2 Part II: Select Source Control BMPs

Certain types of activities and facilities may require source control BMPs. Determine whether there are pollutant-generating activities or facilities in the project that warrant source controls. For detailed descriptions of the source control activities and associated BMPs, see Section 2.2 of Volume IV of Ecology's SMMWW or Chapter 8 of the SMMEW. Source control BMPs for the activities listed in Section 5-2.1 must be specified to reduce pollutants. Any deviations from the source control BMPs listed in either the SMMWW or the SMMEW must provide equivalent pollution source control benefits. The Project File must include documentation for why the deviation is considered equivalent. Section 5-3.5.3 describes the process for seeking approval of such deviations. The project may have additional source control responsibilities as a result of area-specific pollution control plans (such as watershed or basin plans, water cleanup plans, groundwater management plans, or lake management plans), ordinances, and regulations.

5-3.3 Part III: Select Flow Control BMPs

For each TDA in the project that exceeds the triggers set forth in Minimum Requirement 6 (see Section 3-3.6 and Figure 3.3, Step 8) and that cannot apply a flow exemption listed in Section 3-3.6.2, select a flow control BMP by using the following process (see Figure 5.3.1).

Step 1: Determine whether stormwater mitigation and management can be handled by the natural landscape or infiltration.

Closely examine the following three stormwater management options for applicability to the project site.

Option 1: The first option is dispersion, which has two components: natural dispersion and engineered dispersion.

- **Natural dispersion** (see BMP FC.01 in Section 5-4.2.2) is further divided into two types of dispersion:
 - Sheet flow dispersion, which discharges unconcentrated runoff directly into areas adjacent to the roadway that are naturally vegetated

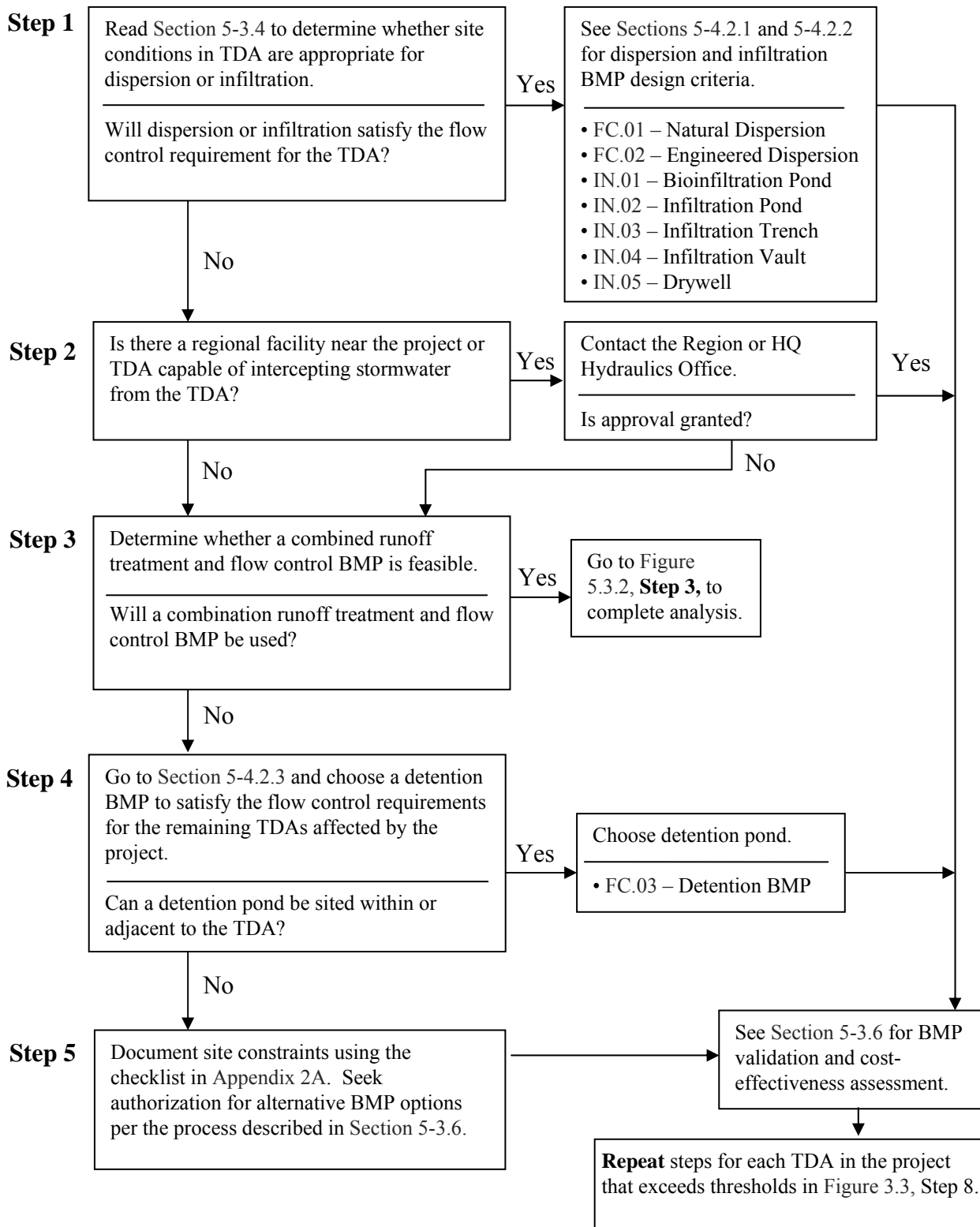

Figure 5.3.1 Flow control BMP selection flow chart.

- Channeled flow dispersion, which collects, conveys, and redisperses runoff into areas that are naturally vegetated
- **Engineered dispersion** (see BMP FC.02 in Section 5-4.2.2) implies that the project is collecting and conveying stormwater to an area that has been landscaped and redeveloped to mimic the benefits of a forested area. The stormwater may not have flowed to the engineered dispersion area before the project. Channeled flows must be redispersed with a flow spreading or dispersal structure.

Option 2: The second option is to infiltrate runoff through soils that meet the site characterization and site suitability criteria for both flow control and runoff treatment. Infiltration treatment facilities must be preceded by a pretreatment facility such as a presettling basin (see Section 5-4.3.1) to reduce plugging. Any of the basic runoff treatment BMPs can also be used for pretreatment. The facility would be designed to meet the requirements for runoff treatment and flow control. However, because such a facility would have to be located on-line, it would need to be quite large to achieve the flow duration standard of Minimum Requirement 6 in Section 3-3.6. Sections 4-5 and 5-4.2.1 provide guidelines and criteria on applications and design of infiltration facilities (see BMPs IN.01, IN.02, IN.03, and IN.04) that provide both flow control and runoff treatment.

Option 3: The third option is to infiltrate runoff through rapidly draining soils that do not meet the site characterization and site suitability criteria for providing adequate runoff treatment. Refer to Section 5-4.2.1 for design criteria for infiltration facilities intended to provide flow control without runoff treatment (see BMPs IN.02 through IN.05). In this option, a basic runoff treatment facility must be added upstream of the facility. The treatment facility would be located off-line with a capacity to treat the runoff treatment design flow rate to the applicable performance goal. (Note that volume-based runoff treatment BMPs are always on-line.) Flow in excess of the design runoff treatment flow rate would bypass untreated into the infiltration basin. The infiltration facility must provide adequate storage volume to achieve the flow duration standard of Minimum Requirement 6 (see Section 3-3.6).

Step 2: Determine whether a regional detention facility is within or near the project limits.

Regional detention facilities are usually owned and operated by the local jurisdiction. A fee is paid to the local jurisdiction to allow project stormwater to flow to the regional facility. This method of stormwater mitigation is useful when the project is within a well-developed watershed with very little right of way to allow for infiltration, dispersion, or detention BMPs.

The designer must work with the local jurisdiction to determine whether the regional detention facility has adequate capacity and the ability to meet target discharge rates to mitigate for project stormwater. This requires that the designer verify with the local jurisdiction the design criteria used to size the pond and outlet control structure. If the regional facility was not designed to control flow durations or has not received approval from

Ecology as an alternative in accordance with Ecology's SMMWW or the SMMEW, then WSDOT cannot fully rely on that facility to meet its flow control needs.

Step 3: Determine whether a combined flow control and runoff treatment facility can be designed for the project.

Combination stormwater BMPs provide both runoff treatment and flow control in one facility; therefore, a combined facility is often less expensive to construct and has reduced maintenance costs when compared to two separate facilities. If the TDA must provide enhanced runoff treatment, evaluate whether a combination stormwater wetland/detention pond should be used. Items to consider with this BMP are maintenance and monitoring. (Refer to BMPs CO.01 and CO.02 in Section 5-4.1.4 for design criteria for combination stormwater BMPs.) For eastern Washington, a bioinfiltration pond (see BMP IN.01) combined with a drywell (see BMP IN.05) can also be used as a combination facility.

Step 4: Select a detention BMP.

If the strategies listed in the preceding three steps cannot mitigate for all TDA flow control requirements, choose a detention BMP (FC.03) from Section 5-4.2.3.

Step 5: Document site constraints and select alternative BMP.

If the strategies listed in the preceding four steps cannot mitigate for all TDA flow control requirements, go to Appendix 2A and document the site constraints. Seek authorization for an alternative BMP using the process discussed in Section 5-3.6.

5-3.4 Part IV: Select Runoff Treatment BMPs

For each TDA in the project that exceeds the triggers set forth in Minimum Requirement 5 (see Section 3-3.5 and Figure 3.3, Step 7), select a runoff treatment BMP by using the following process (see Figure 5.3.2).

Step 1: If dispersion was selected in Step 1 of Figure 5.3.1, no further steps are required.

Step 2: If infiltration was selected in Step 1 of Figure 5.3.1, see Section 4-5 for detailed infiltration design criteria.

Step 3: Determine the receiving waters, possible pollutants of concern, and any additional local jurisdictional requirements.

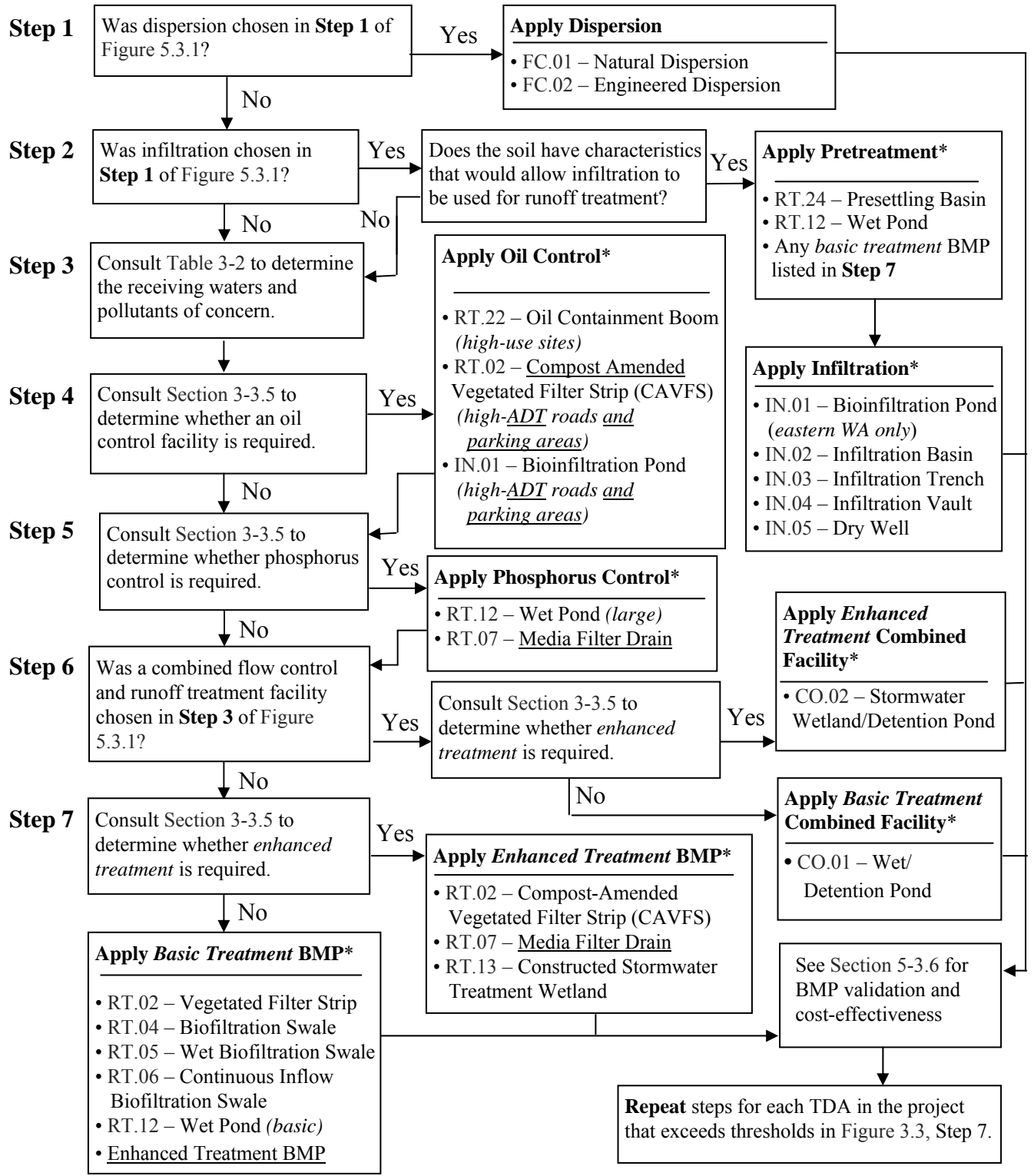

*If these BMPs cannot be sited within or adjacent to the TDA, document the site constraints using the checklist in Appendix 2A. Seek authorization for alternative BMP options per the process described in Section 5-3.6.

Figure 5.3.2 Runoff treatment BMP selection flow chart.

To obtain a more complete determination of the potential impacts of a stormwater discharge, conduct a downstream analysis to determine the natural receiving waters (groundwater, wetland, lake, river, stream, or marine water) for the stormwater drainage from the project site. This is necessary to determine the applicable treatment menu from which to select treatment facilities. Verify the receiving waters with the local jurisdiction having review responsibility. If the discharge is to a local municipal storm drainage system, the receiving waters for the drainage system must be determined.

Consult the local jurisdiction to determine whether any type of water quality management plans, local ordinances, or local regulations have established specific requirements for the receiving waters. If approved by Ecology, requirements in these documents should replace or supplement guidelines and criteria given herein with regard to stormwater flow control and runoff treatment. Examples of such plans include the following:

- **Watershed or basin plans:** These plans may cover a wide variety of geographic scales (such as water resource inventory areas or subbasins of a few square miles). They may be focused solely on establishing stormwater requirements (such as stormwater basin plans) or may address a number of pollution and water quantity issues, including urban stormwater (for example, Puget Sound nonpoint action plans).
- **Water cleanup plans:** These plans are written to establish a total maximum daily load (TMDL) of a pollutant or pollutants in a specific receiving water or basin and to identify actions necessary to remain below that maximum loading. The plans may identify discharge limitations or management limitations (such as use of specific treatment facilities) for stormwater discharges from new and redevelopment projects.
- **Groundwater management plans** (wellhead protection plans and sole-source aquifers): To protect groundwater quality and quantity, these plans may identify actions required of stormwater discharges.
- **Lake management plans:** These plans are developed to protect lakes from eutrophication due to phosphorus-laden runoff from the drainage basin. Control of phosphorus from new development is a likely requirement in any such plans.

Step 4: Determine whether an oil control facility or device is required.

Oil control devices are required for projects that exceed the oil control thresholds in Section 3-3.5.4.

If oil control is required, select and apply an oil treatment facility. (See Figure 5.3.2 for available options that provide oil control and Table 4-11 for a list of other oil control BMPs used for stormwater discharges to UIC facilities.) The designer should first read and understand the requirements of Section 5-3.6 before moving forward with choosing an oil control BMP from this section.

An oil control BMP should be placed as close to the source as possible, but protected from sediment. Adsorptive oil containment booms can be placed on top of the water in sediment control devices and can be used in ponds and vaults.

Step 5: Determine whether control of phosphorus is required.

Please refer to the plans, ordinances, and regulations mentioned in Step 3 as sources of information. The requirement to provide phosphorus control is determined by the local jurisdiction, Ecology, or the U.S. Environmental Protection Agency (U.S. EPA).

The local jurisdiction may have developed a management plan and implementing ordinances or regulations for control of phosphorus discharging to receiving waters from runoff of the new/ development areas.

If phosphorus control is required, select and apply a phosphorus treatment facility (see Figure 5.3.2 for available options that provide phosphorus control). If enhanced treatment for dissolved metals removal is required in addition to phosphorus control, select the media filter drain since it provides both phosphorus and enhanced runoff treatment.

Step 6: Was a combined flow control and runoff treatment facility chosen in Step 3 of Figure 5.3.1?

To determine whether basic or enhanced runoff treatment is necessary, see Section 3-3.5 and use Table 3-1. Select a constructed stormwater wetland/detention pond for enhanced runoff treatment or select a wet/detention pond if only basic runoff treatment is required for the TDA.

Step 7: Determine whether enhanced treatment is required.

To determine whether basic or enhanced runoff treatment is necessary, see Section 3-3.5 and use Table 3-1. Select an appropriate enhanced runoff treatment or basic runoff treatment BMP from Figure 5.3.2, Step 7.

Repeat Figure 5.3.2 for each TDA in the project.

5-3.5 Seeking Authorization for Alternative BMP Options

Note: Prior to seeking approval, designers should consult the Postpublication Updates in the online Highway Runoff Manual (HRM) to check whether the alternative BMP has been added as an available option.

This chapter contains Ecology-approved permanent BMPs that WSDOT finds acceptable for highway applications. However, site and project constraints or programmatic constraints may compel a designer to consider alternatives to BMPs available in this manual. The pursuit of alternative options falls into the following categories:

1. Ecology-approved BMPs not included in this manual because WSDOT does not consider them viable for widespread highway application due to cost considerations associated with their maintenance. BMPs falling under this category received approval for *general use* by Ecology.
2. BMPs with potential for widespread highway applications that have not received *general use* approval by Ecology. A BMP falling under this category is considered an emerging technology and may or may not have received a *conditional use* or *pilot use* designation by Ecology.
3. Project- or site-specific approaches for seeking compliance with federal and state water quality regulations via the *demonstrative approach*.

Figures 5.3.6.1 and 5.3.6.2 are general descriptions of the processes for seeking approval for runoff treatment and flow control BMPs not currently contained in the HRM. ***To help avoid delays in processing requests, consult Region Hydraulics Office and HQ ESO Stormwater & Watersheds Program staff prior to initiating this process.***

5-3.5.1 Category 1: Ecology-Approved BMPs Not in the HRM

Ecology-approved BMPs not included in the HRM require Region Hydraulics Office and Maintenance Superintendent approval for use. Design criteria for these BMPs are available on WSDOT's HRM website: www.wsdot.wa.gov/NR/rdonlyres/A298F932-2F96-469D-AC3D-56CBEF1D782B/0/Category1BMP.pdf. However, if WSDOT approval is not granted, an acceptable alternative must be selected.

5-3.5.2 Category 2: Emerging Technologies

Ecology's stormwater management guidance manuals make provisions for using emerging BMP technologies, which they define as:

Technologies that have not been evaluated using approved protocols, but for which preliminary data indicate that they may provide a desirable level of stormwater pollutant removal.

Use of an emerging technology requires WSDOT as well as Ecology approvals, as described in Figure 5.3.6.2.¹ Designers should seek authorization far enough in advance to allow for contingencies if use of the emerging technology is denied. Note: Internal review and approval of an emerging technology's conceptual design and approach can take at least three months.

¹ Ecology's *Emerging Technologies* web page contains additional information regarding Ecology's program to evaluate emerging stormwater treatment technologies.

In some instances, an emerging technology may have already received a *pilot use* or *conditional use* designation from Ecology.¹ For emerging technologies not currently in widespread use, the *pilot use* designation allows limited use by projects to enable field-testing of its performance, subject to an Ecology-approved monitoring plan and the limitations imposed on the number and location of such installations.

Ecology's *conditional use* designation applies to emerging technologies currently in widespread use in Washington (or considered equivalent to Ecology-approved technologies) that it considers likely to attain a *general use* designation—provided that a necessary field evaluation to obtain a *general use* designation is completed within a specified time period.

Conditional use BMPs **included** in the HRM can be used on any project location that meets the terms of the *conditional use* designation. However, the designer must contact the HQ ESO Stormwater & Watersheds Program to learn whether WSDOT wants to use the site to fulfill the monitoring requirement of the *conditional use* designation.

Ideally, the project design team identifies the need for potentially pursuing an emerging technologies approach during scoping (the project definition phase) or early in the design phase. This allows the design team, in consultation with the HQ ESO Stormwater & Watersheds Program, to account for the expenses involved in monitoring and evaluating the BMP's performance when programming project costs.

During the project design phase, the design team develops the conceptual design and documents the technical and engineering basis for the approach (*conceptual design thesis*). The conceptual design thesis provides the necessary background to enable the Region Hydraulics Office and the HQ ESO Stormwater & Watersheds Program to make an informed decision about whether it is in the department's interest to invest in the evaluation of the technology.² Region Hydraulics Office and HQ ESO Stormwater & Watersheds Program assistance may be sought in preparing this documentation, which should include:

- A description of the emerging technology and its application.
- Rationale for its development and use.
- Existing hydraulic and treatment performance data for the emerging technology (if available).
- General design and construction considerations.
- Site-suitability characteristics.
- Hydraulic design.
- Operation and maintenance requirements.

¹ Ecology's *Emerging Technologies* web page contains the designation status of emerging technologies undergoing evaluation.

² This documentation already exists for BMPs with an Ecology *pilot-* or *conditional-use* designation and is available on Ecology's *Emerging Technologies* web page.

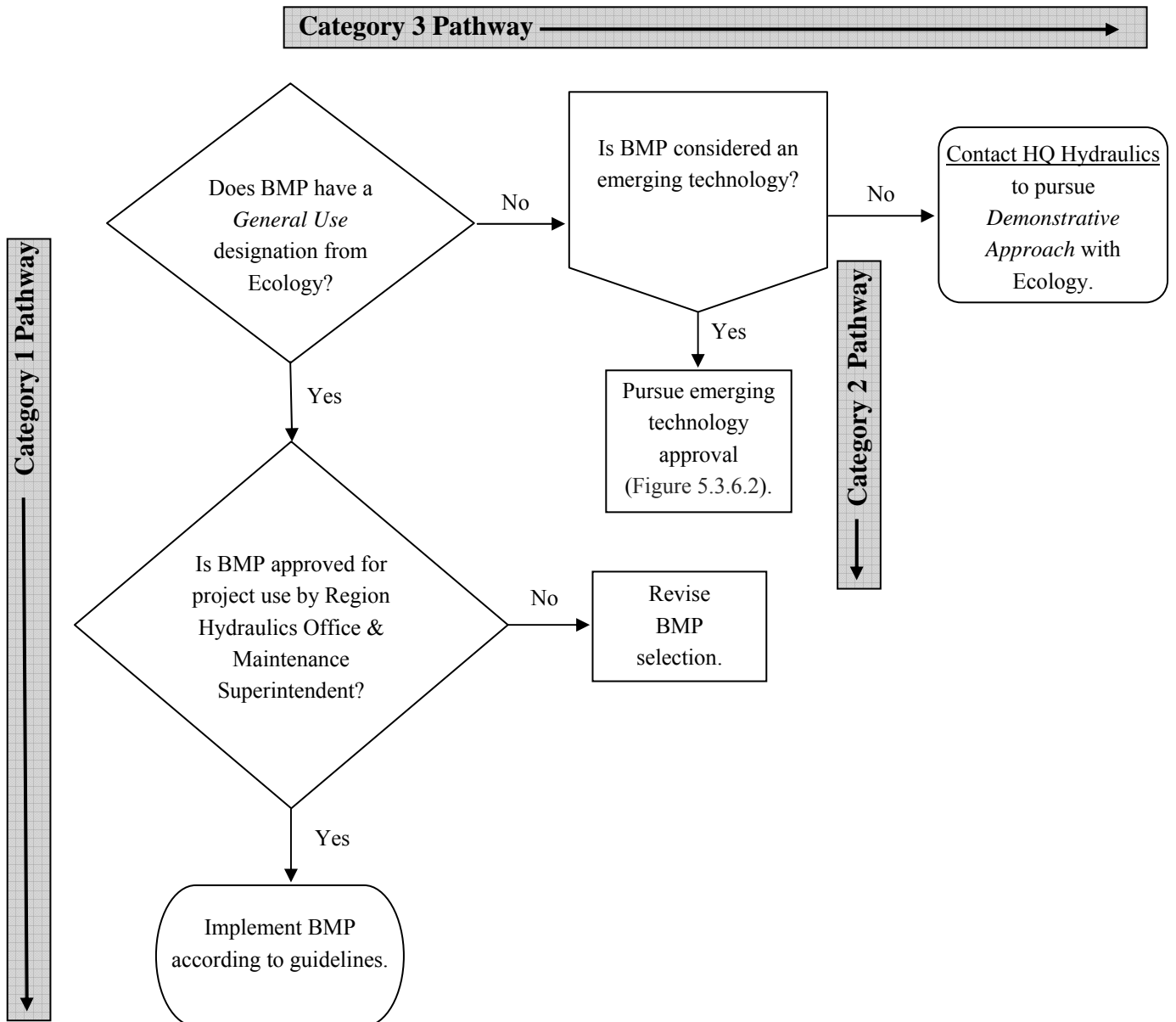

Figure 5.3.6.1. Process for using BMPs not in the HRM.

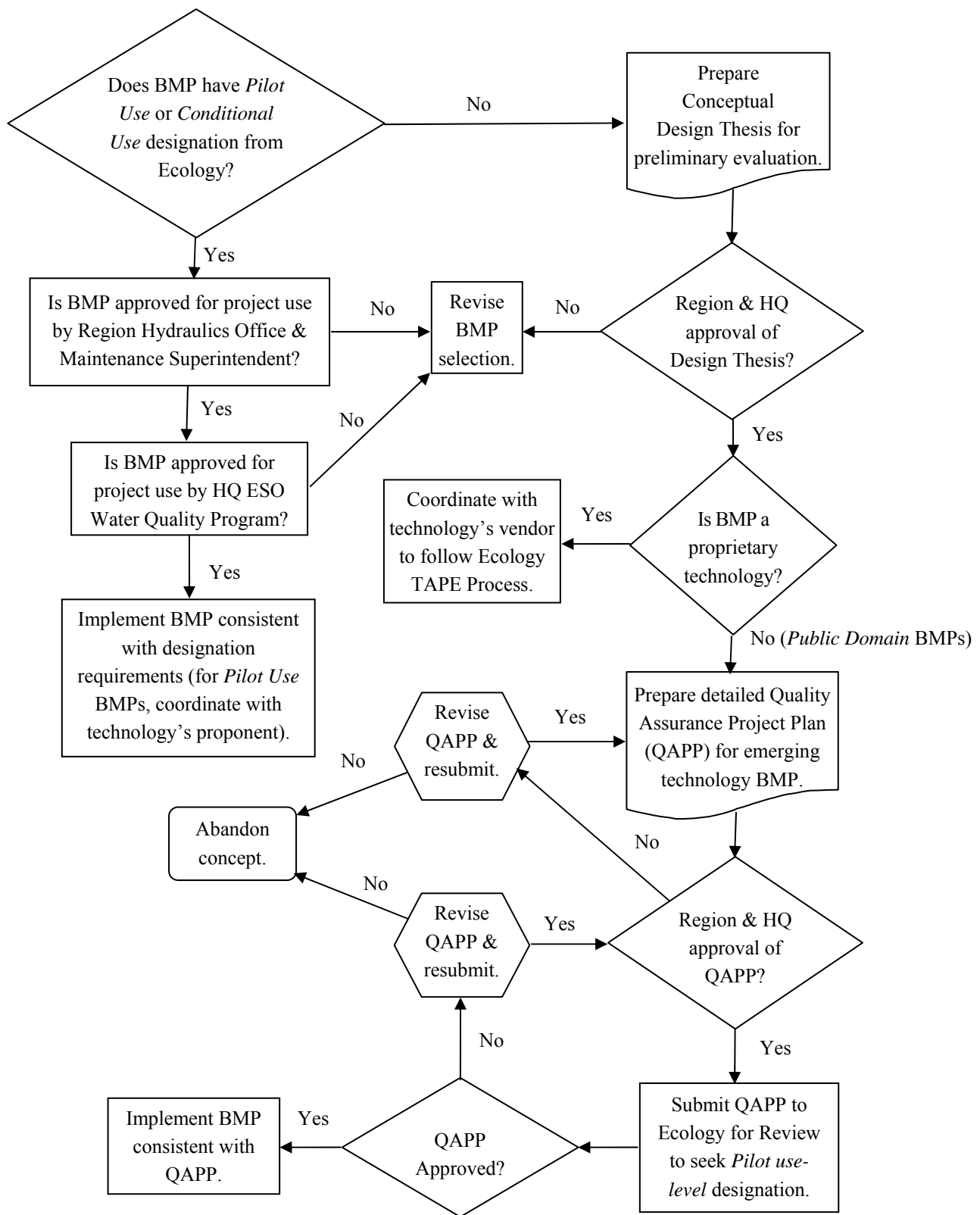

Figure 5.3.6.2. Emerging technology approval process: Category 2 pathway.

Pursuing evaluation of an emerging proprietary technology requires coordination with the technology's vendor to follow Ecology's Technology Assessment Protocol (TAPE) and evaluation process. Additional information on the TAPE protocol can be found on Ecology's *Emerging Technologies* web page.

Public domain technologies require preparation of a detailed Quality Assurance Project Plan (QAPP) for evaluating the proposed emerging technology that is acceptable to WSDOT and Ecology. In addition to covering the elements included in the design thesis, the QAPP describes the procedures to be followed in evaluating the emerging technology. Region Hydraulics Office and HQ ESO Stormwater & Watersheds Program assistance should be sought in preparing the QAPP. Ecology's January 2008 publication, *Guidelines for Preparing Quality Assurance Project Plans for Environmental Studies*, presents detailed instructions on preparing a QAPP. The project's environmental permit coordinator needs to include the design thesis and QAPP in project submittals early in the permitting process. Upon Ecology's approval of the QAPP, the design team must remain involved through completion of construction to ensure proper installation of the facility and any monitoring-related elements.

Once the facility is operational, HQ ESO Stormwater & Watersheds Program staff will assist the region in implementing the QAPP; completing the evaluation package (including monitoring data and data analysis); petitioning Ecology for evaluation and assignment of use-level designation; and continuing development of the technology where applicable.

5-3.5.3 Category 3: The Demonstrative Approach

Projects have the option of seeking compliance with water quality regulations via the *demonstrative approach* (see Section 1-1.3 for a comparison of the *demonstrative approach* with the *presumptive approach*). The *demonstrative approach* requires submittal of a site-specific stormwater management proposal to the HQ Hydraulics Office for Ecology review and approval.

Ecology approval requires demonstrating that the project will not adversely affect water quality by providing appropriate supporting data showing that the alternative approach satisfies state and federal water quality laws. In developing alternate treatment and control options, it is important to consider and document the site limitations using the *Engineering and Economic Feasibility Evaluation Checklist* (see Section 2-7.4 and Appendix 2A). While this evaluative tool will provide some of the necessary background information to make decisions regarding alternative approaches, it will not in and of itself satisfy federal and state requirements to make maximum extent practicable (MEP) and all known, available and reasonable technologies (AKART) determinations. Projects pursuing this approach should contact the HQ Hydraulics Office directly, as the timeline and expectations for providing this technical justification may be extensive (depending on the complexity of the individual project and the nature of the receiving water environment).

Depending on the nature of the alternative approach proposal, a dilution analysis may be needed to demonstrate that the project will not adversely affect water quality. If applicable to

the proposal, the dilution analysis needs to be based on (1) critical flow rates of the discharge and the receiving water and (2) estimated concentrations of pollutants of concern in the discharge and the upgradient receiving water. A standard procedure for determining the value of those four variables has yet to be developed by Ecology. Until it is developed, Ecology will have to make case-by-case decisions concerning valid approaches to the analysis.

5-3.6 BMP Validation and Cost-Effectiveness

Once a stormwater BMP is selected, the designer should be aware that there are costs and obligations involved in the long-term operation and maintenance of the BMP. For this reason, the designer should contact the local maintenance office and discuss the proposed stormwater BMPs and overall stormwater design to determine any area-specific BMP restrictions or requirements. Table 5.3.1 helps the designer evaluate the cost-effectiveness of different stormwater BMPs by assessing typical construction costs, annual operation and maintenance (O&M) expenses, and effective life (how soon the BMP may need to be replaced).

5-3.6.1 General Maintenance Requirements

Design with maintenance in mind. Maintenance is crucial to performance of runoff treatment and flow control BMPs; therefore, provisions to facilitate maintenance operations must be built into the project when the BMP is installed. Maintenance must be a basic consideration in design and in determination of cost. Include maintenance personnel early and throughout the design process. During discussions with maintenance personnel, describe the maintenance procedures that will need to be performed on the BMP. This will help ensure future maintenance work and potential access needs are clearly understood.

Table 5.3.1. Relative rankings of cost elements and effective life of BMP options.

BMP	Capital Costs	O&M Costs	Effective Life ¹
Vegetated Filter Strip	Low	Low	20–50 years
Wet Biofiltration Swale	Low to Moderate	Low to Moderate	5–20 years
Continuous Inflow Biofiltration Swale	Low to Moderate	Low	5–20 years
Media Filter Drain	Low	Low to Moderate	5–20 years ²
Compost-Amended Vegetated Filter Strip	Low	Low	5–20 years ²
Wet Pond	Moderate to High	Low to Moderate	20–50 years
Combined Wet/Detention Pond	Moderate	Low to Moderate	20–50 years
Constructed Stormwater Treatment Wetland	Moderate to High	Moderate	20–50 years
Combined Stormwater Wetland/Detention Pond	Low to Moderate	Moderate	20–50 years
Wet Vault (Category 1 BMP)	Moderate to High	High	50–100 years
Combined Wet/Detention Vault (Category 1 BMP)	Moderate to High	High	50–100 years
Bioinfiltration Pond	Low to Moderate	Low	5–20 years
Infiltration Pond	Moderate	Moderate	5–10 years before deep tilling required
Infiltration Trench	Moderate to High	Moderate	10–15 years
Infiltration Vault	Moderate	Moderate to High	5–10 years
Drywell	Low to Moderate	Low to Moderate	5–20 years
Engineered Dispersion	Low	Low	
Detention Pond	Moderate	Low	20–50 years
Detention Vault (Category 1 BMP)	Moderate to High	High	50–100 years
Detention Tank (Category 1 BMP)	Moderate to High	High	50–100 years
Presettling Basin	Low to Moderate	Moderate	
Proprietary Presettling Devices	Moderate	Moderate	50–100 years

Sources: Adapted from Young et al. (1996); Claytor and Schueler (1996); U.S. EPA (1993); and others.

¹ Assumes regular maintenance, occasional removal of accumulated materials, and removal of any clogged media.

² Estimated based on best professional judgment.

General Maintenance Access Requirements

Access Roads

- Maximum grade for access roads will vary depending on what type of vehicle the local area maintenance office uses. The designer should contact the local area maintenance office to discuss this issue.
- Outside turning radius should be a minimum of 40 feet.
- Access roads should be 15 feet wide on curves and 12 feet wide (minimum) on straight sections.
- Access roads may be constructed with an asphalt or gravel surface or with modular grid pavement. All surfaces must conform to the WSDOT *Standard Specifications for Road, Bridge, and Municipal Construction (Standard Specifications)* and to manufacturer's specifications if the surfacing material is a vendor product.

- A paved apron must be provided where access roads connect to paved public roadways.
- Access roads used by Vector trucks must be built to support loads up to 80,000 pounds.
- Access roads used by trackhoes or dump trucks must be built to support loads up to 40,000 pounds.
- Other access roads must be built to support loads up to 30,000 pounds.
- Fence gates should be located only on straight sections of road.
- If a fence is required, access should be limited by a double-posted gate or by bollards—that is, two fixed bollards on each side of the access road and two removable bollards located equally between the fixed bollards. (See the *Design Manual* for guidelines on fencing requirements).
- The fence gate should be located so there is an adequate area in front of the gate to park a vehicle, out of traffic, while the gate is being opened. The parking area should be sized based on the largest vehicle that will be needed to perform BMP maintenance.

Other

- Side slopes for earthen/grass embankments should not exceed 3H:1V to facilitate mowing. If side slopes are greater than 3H:1V, consult with local area maintenance personnel to ensure tall grass does not restrict site access or pose other issues. Steep embankments may need to be planted with low-maintenance, low-growing ground cover.
- It is recommended that BMPs that require removal of sediment have a fixed vertical sediment depth marker installed in the structure to measure sediment deposition over time. Consult the local area maintenance office regarding the design and use of this marker.

Vaults/Tanks/Catch Basins/Manholes

Access Roads

- Vaults and tanks should be located out of the roadway prism whenever possible. In most areas, closure of traffic lanes to clean vaults or tanks is not allowed during daylight hours. Maintenance at night involves additional risk and requires worksite lighting and possibly noise restrictions.
- Access roads are needed to the stormwater structure access panel if applicable; the inlet and outlet control structure; and at least one access point per cell.
- Manhole and catch basin lids must be set within or at the edge of the access road and at least 3 feet from a property line. Manhole and catch basin lids for

control structures must be locking and rim elevations must match proposed finish grade.

- The Vactor truck needs to park directly adjacent to the stormwater structure. Within 6 feet of the truck, the boom has swing-and-lift capability; however, for most vaults, the operator needs to be able to center the boom directly over the suction point. For deep vaults, the operator typically starts at one end and moves the Vactor truck along the vault to clean it from end to end. The deeper the suction tubes, the harder it becomes to drag the boom around, so it must be centered directly above the crew person working down in the stormwater structure.
- Right of way may be needed for vault and tank maintenance. It is recommended that any tract not abutting WSDOT right of way have a 15- to 20-foot-wide extension of the tract to an acceptable access location. Enough room must be designed around all underground vaults and tanks to provide space for necessary support equipment, including holding tanks, towed pumps, and equipment for confined-space entry. Consult with the local area maintenance office on access needs for support equipment.

Openings

- Access must be provided over the inlet pipe, over the outlet structure, and to each cell.
- Access openings must be positioned a maximum of 50 feet from any location within the vault or tank. Additional access points may be needed on large vaults and tanks.
- If more than one V is provided in the vault floor, access to each V must be provided.
- For vaults with greater than 1250 square feet of floor area, a 5- by 10-foot removable panel (instead of a standard frame, grate, and solid cover) should be provided over the inlet pipe.
- Removable panels over vaults must be at grade, have stainless steel lifting eyes, and weigh no more than 5 tons per panel.
- Vaults with widths of 10 feet or less must have removable lids.
- For vaults under roadways, the removable panel must be located outside the travel lanes. Alternatively, multiple standard locking manhole covers may be provided.
- All access openings, except those covered by removable panels, may have round solid locking lids or 3-foot-square locking diamond plate covers.
- Tank access openings may have round, solid locking lids (usually ½- to ⅝-inch-diameter Allen-head cap screws).

- For tanks, riser-type manholes constructed of 36-inch-minimum-diameter corrugated metal pipe of the same gage as the tank material may be used for access along the length of the tank and at the upstream terminus of the tank in a backup system. The top slab is separated (1-inch-minimum-gap) from the top of the riser to allow for deflections from vehicle loadings without damaging the riser tank.

Entry

- Ladders and handholds need be provided only at the outlet pipe and inlet pipe, and as needed to meet WISHA confined-space requirements.
- Stormwater structures must comply with the WISHA confined-space requirements, which include clearly marking entrances to confined-space areas. This may be accomplished by hanging a removable sign in the access riser, just under the access lid.
- If ladders are greater than 20 feet long, fall protection that meets WISHA requirements must be provided.
- Ventilation pipes—minimum 12-inch-diameter or equivalent—should be provided in all four corners of vaults and tanks to allow for artificial ventilation for maintenance personnel.
- Vaults with manhole access at 12-foot intervals or with removable panels over the entire vault need not provide corner ventilation pipes as specified above.
- Internal structural walls of large vaults should be provided with openings sufficient for maintenance access between cells. When applicable, the openings should be sized and situated to allow access to the V in the vault floor.
- The minimum internal height should be 7 feet from the highest point of the vault floor (not sump), and the minimum width should be 4 feet. The minimum internal height requirement may not be applicable for any areas covered by removable panels.

Other Access Issues

- All vaults and tanks need a bypass or valve to take the BMP off-line.
- The gravity drain criteria for ponds (see below) should apply to the wet vaults and combined wet/detention vaults.
- For maintenance access, the maximum depth from finished grade to the bottom of the vault or tank should be 20 feet or less. Most Vector trucks become inefficient below this depth. Contact the local area maintenance office to discuss operating depths of the equipment for the area.

Ponds

Access Roads

- One or more access roads must be provided to the outlet control structure and other drainage structures associated with the pond (such as inlet or bypass structures) to allow for inspection and maintenance.
- An access roadway is needed for removal of sediment with a trackhoe and truck. A ramp must extend to the pond bottom if the pond bottom area is greater than 1500 square feet (measured without the ramp), and it may end at an elevation 4 feet above the pond bottom if the pond bottom is less than 1500 square feet (measured without the ramp). At large, deep ponds, truck access to the pond bottom via an access ramp is necessary so that excavated sediment and other material can be loaded into a truck in the pond bottom. At small, deep ponds, the truck can remain on the ramp for loading. At small, shallow ponds, a ramp to the bottom may not be required if the trackhoe can load a truck parked at the pond edge or on the internal berm of a detention pond (trackhoes can negotiate interior pond side slopes). These requirements may change based on discussion with the local area maintenance office regarding the type of vehicle typically used for that area.
- Access ramps must be a minimum of 3H:1V.

Other Access Issues

- Wet ponds, constructed wetlands, and other stormwater structures with high base flows must have a bypass or valve to take the BMP off-line.
- For wet ponds, combined wet/detention ponds, wet vaults, combined wet/detention vaults, constructed stormwater treatment wetlands, and combined stormwater treatment wetlands/detention ponds, a gravity drain for maintenance should be installed if grade allows. This drain can be installed to drain any of the cells.

Intent: It is anticipated that in most cases, sediment removal will be needed only for the first cell. The gravity drain is intended to allow water from the first cell to be drained to the second cell when the first cell is pumped dry for cleaning.

- If placed within a dividing berm or baffle, the drain invert must be at least 6 inches below the top elevation of the dividing berm or baffle. Deeper drains are encouraged, where feasible, but they must be no deeper than 18 inches above the pond bottom.

Intent: Highly sediment-laden water will be less likely to be released from the pond when it is drained for maintenance.

- The drain must be at least 8 inches in diameter and controlled by a valve. Use of a shear gate is allowed only at the inlet end of a pipe located within an approved structure.

Intent: Shear gates often leak if water pressure pushes on the side of the gate opposite the seal. The gate should be situated so that water pressure pushes toward the seal.

- Operational access to the valve must be provided at the finished ground surface.
- The valve location must be accessible and well marked, with 1 foot of paving placed around the box. It must also be protected from damage and unauthorized operation.
- A valve box is allowed to a maximum depth of 5 feet without an access manhole. If the valve box is over 5 feet deep, an access manhole or vault is required.
- Specify that all metal parts must be corrosion-resistant. Galvanized materials should not be used unless unavoidable.

Intent: Galvanized metal contributes zinc to stormwater, sometimes in very high concentrations.

5-4 BMP Design Criteria

Note: Follow the BMP selection process in Section 5-3 before selecting a BMP.

The stormwater management methods in this section have been categorized in order of preferred use and grouped according to similar composition and function. Each BMP has an associated number to distinguish it from other BMPs with similar names. The numbering convention represents the following classifications:

- RT.XX – Runoff Treatment BMPs
- FC.XX – Flow Control BMPs
- IN.XX – Infiltration BMPs
- CO.XX – Combination BMPs

5-4.1 Runoff Treatment Methods

The primary function of the BMPs listed in this section is to meet Minimum Requirement 5 (Runoff Treatment) in Section 3-3.5.

5-4.1.1 Infiltration BMPs

Some infiltration BMPs (IN.01, Bioinfiltration Pond, IN.02, Infiltration Pond, IN.03, Infiltration Trench, and IN.04, Infiltration Vault) can provide both runoff treatment and flow control functions. These BMPs are discussed in detail in Section 5-4.2.1. (See the *Site Suitability Criteria* in Section 4-5.1 for additional requirements.)

5-4.1.2 Dispersion BMPs

Dispersion BMPs (FC.01, Natural Dispersion, and FC.02, Engineered Dispersion) provide both runoff treatment and flow control functions. These BMPs are discussed in detail in Section 5-4.2.2.

5-4.1.3 Biofiltration BMPs

RT.02 – Vegetated Filter Strip



Vegetated Filter Strip in Median Along I-5 in Snohomish County.

Introduction

General Description

Vegetated filter strips are land areas of planted vegetation and amended soils situated between the pavement surface and a surface water collection system, pond, wetland, stream, or river. (See Figure RT.02.1 for an illustration of a typical vegetated filter strip.) The term *buffer strip* is sometimes used interchangeably with vegetated filter strip, but in this manual, *buffer strip* refers to an area of natural indigenous vegetation that can be enhanced or preserved as part of a riparian buffer or stormwater dispersion system.

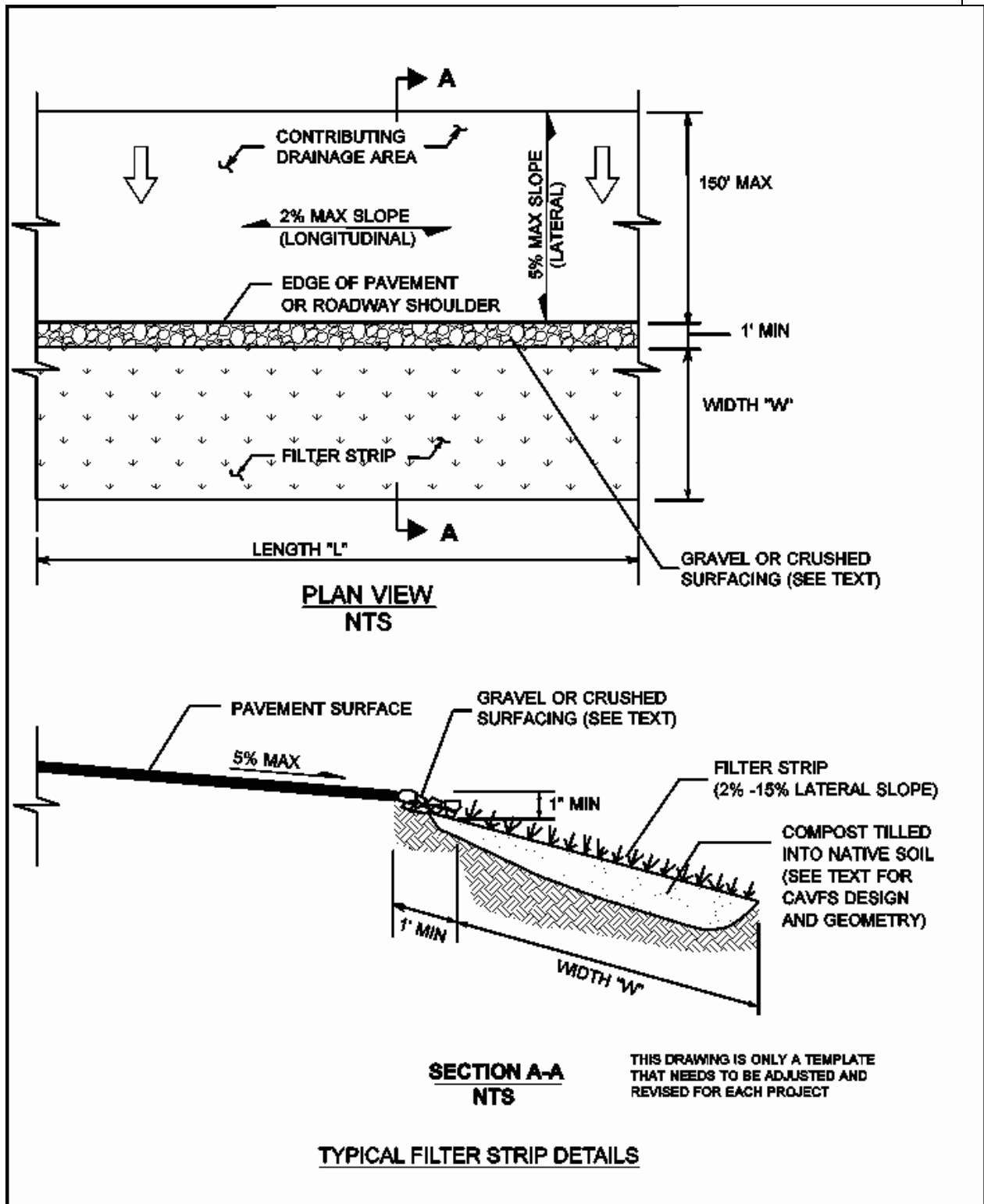

Figure RT.02.1. Typical vegetated filter strip.

Vegetated filter strips accept overland sheet flow runoff from adjacent impervious areas. They rely on their flat cross slope and dense vegetation to maintain sheet flows. Their primary purpose is to remove sediments and other pollutants coming directly off the pavement. Vegetated filter strips function by slowing runoff velocities, trapping sediment and other pollutants, and providing some infiltration and biologic uptake.

The design approach for vegetated filter strips involves site design techniques to maintain prescribed maximum sheet flow distances, as well as to ensure adequate temporary storage, so that the design storm runoff is treated. There is limited ponding or storage associated with vegetated filter strips unless soil amendments and subsurface storage are incorporated into the design to reduce runoff volumes and peak discharges.

Vegetated filter strips can also be used as a pretreatment BMP in conjunction with bioretention, biofiltration, media filtration, or infiltration BMPs. The sediment and particulate pollutant load that could reach the primary BMP is reduced by the pretreatment, which in turn reduces maintenance costs and enhances the pollutant-removal capabilities of the primary BMP.

There are three methods described in this section for designing vegetated filter strips: *basic* vegetated filter strips, *compost-amended* vegetated filter strips (CAVFS), and *narrow area* vegetated filter strips. The narrow area vegetated filter strip is the simplest method to design; however, its use is limited to impervious flow paths less than 30 feet. If space is available to use the basic vegetated filter strip design or the CAVFS, either of the two designs should be used in preference to the narrow area vegetated filter strip. For flow paths greater than 30 feet, designers should follow the design method for the basic vegetated filter strip or the CAVFS.

The basic vegetated filter strip is a compacted roadside embankment that is subsequently hydroseeded. The CAVFS is a variation of the basic vegetated filter strip that adds soil amendments to the roadside embankment. The soil amendments improve infiltration characteristics, increase surface roughness, and improve plant sustainability.

The CAVFS design incorporates compost into the native soils per the criteria in Section 5-4.3.2. The CAVFS bed should have a final organic content of 10%. Once permanent vegetation is established, the advantages of the CAVFS are higher surface roughness; greater retention and infiltration capacity; improved removal of soluble cationic contaminants through sorption; improved overall vegetative health; and a reduction of invasive weeds. Compost-amended systems have somewhat higher construction costs due to more expensive materials, but require less land area for runoff treatment, which can reduce overall costs.

Applications and Limitations

Vegetated filter strips (*narrow area* and *basic*) can be used to meet basic runoff treatment objectives (see Table 3-1) or as part of a treatment train to provide additional removal of phosphorus or dissolved metals. (See Tables 5.3.1 and 5.3.2 at the following web link on

Category 1 BMPs: (www.wsdot.wa.gov/NR/rdonlyres/A298F932-2F96-469D-AC3D-6CBEF1D782B/0/Category1BMP.pdf.)

CAVFS can be used to meet basic runoff treatment and enhanced runoff treatment objectives.

Applications

- Vegetated filter strips can be effective in reducing sediments and the pollutants associated with sediments such as phosphorus, pesticides, or insoluble metallic salts.
- Because they do not pond water on the surface for long periods, vegetated filter strips help maintain the temperature norms of the water and deter the creation of habitat for disease vectors such as mosquitoes.
- In less urbanized areas, vegetated filter strips can generally be located on existing roadside embankments, reducing the need for additional right of way acquisitions.
- Designs can be modified to reduce runoff volumes and peak flows when needed or desired to reduce right of way acquisitions.

Limitations

- If sheet flow cannot be maintained, vegetated filter strips will not be effective.
- Vegetated filter strips are generally not suitable for steep slopes or large impervious areas that can generate high-velocity runoff.
- Use of vegetated filter strips can be impracticable in watersheds where open land is scarce or expensive.
- For most project applications where less than 10 feet of roadside embankment is available for water quality treatment, the media filter drain (see BMP RT.07) is a more suitable BMP option.
- Improper grading can render this BMP ineffective.
- The flow attenuation properties of vegetated filter strips and amended vegetated filter strips are largely unknown. Qualitative evidence indicates that on outwash soils (National Resources Conservation Service [NRCS] Groups A and B), the compost-amended vegetated filter strip (CAVFS) can attenuate large quantities of runoff. Monitoring studies are being conducted to evaluate these properties and ultimately give designers the ability to model water losses in vegetated filter strips.
- Design methodology for sizing CAVFS in western Washington (see Section 4-5.3.3.1) is different than the design methodology for sizing basic vegetated filter strips in western Washington.

- Design methodology for sizing CAVFS in eastern Washington is identical to the design methodology for sizing basic vegetated filter strips in eastern Washington.

Design Flow Elements

Flows to Be Treated

Vegetated filter strips must be designed to treat the runoff treatment flow rate discussed in Section 3-3.5 under Minimum Requirement 5 and the guidelines and criteria provided in this section. Hydrologic methods are presented in Sections 4-3 and 4-4.

CAVFS must be designed to treat the runoff treatment flow rate discussed in Section 4-5.3.3.1.

Structural Design Considerations

Geometry

Design Criteria and Specifications

Following are the key design elements of vegetated filter strip systems.

Drainage Area Limitations

- Vegetated filter strips are used to treat small drainage areas. Flow must enter the vegetated filter strip as sheet flow spread out over the length (long dimension perpendicular to flow) of the strip, generally no deeper than 1 inch. For basic vegetated filter strips and CAVFS, the greatest flow path from the contributing area delivering sheet flow to the vegetated filter strip should not exceed 150 feet. For the narrow area vegetated filter strip, the maximum contributing flow path should not exceed 30 feet.
- The longitudinal slope of the contributing drainage area parallel to the edge of pavement should be 2% or less.
- The lateral slope of the contributing drainage area perpendicular to the pavement edge should be 5% or less.
- Vegetated filter strips should be fully integrated within site designs.
- Vegetated filter strips should be constructed outside the natural stream buffer area whenever possible to maintain a more natural buffer along the streambank.

Vegetated Filter Strip Geometry

- Applicable for basic vegetated filter strips in eastern and western Washington and CAVFS in eastern Washington.
 - Vegetated filter strips must provide a minimum residence time of 9 minutes for full water quality treatment in eastern Washington. In

western Washington, a flow rate adjustment (described below) is needed to use the 9-minute criterion.

- Vegetated filter strips can be used for pretreatment to another water quality BMP. Wherever a basic vegetated filter strip or CAVFS system cannot fit within the available space, a narrow area vegetated filter strip system can be used solely as a pretreatment device. A narrow area design should have a minimum width of 4 feet and should take advantage of all available space.
- Basic vegetated filter strips should be designed for lateral slopes (along the direction of flow) between 2% and 15%. Steeper slopes encourage the development of concentrated flow; flatter slopes encourage standing water. Vegetated filter strips should not be used on soils that cannot sustain a dense grass cover with high flow retardance.

In areas where lateral grades are between 15% and 25%, designers should consider using a CAVFS or a media filter drain (see BMP RT.07). The media filter drain will usually require less treatment area to achieve the water quality treatment objectives.

- The minimum width of the vegetated filter strip generally is dictated by the design method.
 - Both the top and toe of the slope should be as flat as possible to encourage sheet flow and prevent erosion.
 - The Manning's n to be used in the vegetated filter strip design calculations depends on the type of soil amendment and vegetation conditions used in the construction of the vegetated filter strip (see Table RT.02.1).
 - When the runoff treatment peak flow rate Q_{wQ} has been established, the design flow velocity can be estimated using Manning's equation to calculate the width of the vegetated filter strip parallel to the direction of flow.
- The geometry guidelines above are applicable for CAVFS in western Washington except for the following clarifications:
 - CAVFS design in western Washington does not have a residence time component or Manning's " n " component. (See Section 4-5.3.3 for design sizing criteria and Section 5-4.3.2 for information on soil amendments.)
 - The CAVFS lateral slope (along the direction of flow) can be no steeper than 25% (4H:1V).

Table RT.02.1. Surface roughness/Manning's n for vegetated filter strip design calculations.

Option	Soil and Vegetation Conditions	Manning's n
1	Fully compacted and hydroseeded	0.20
2	Compaction minimized and soils amended, hydroseeded	0.35
3	Compaction minimized; soils amended to a minimum 10% organic content (see Section 5-4.3.2); hydroseeded; grass maintained at 95% density and 4-inch length via mowing; periodic reseeding; possible landscaping with herbaceous shrubs	0.40*
4	Compost-amended vegetated filter strip: compaction minimized, soils amended to a minimum 10% organic content (see Section 5-4.3.2), vegetated filter strip top-dressed with ≥ 3 inches vegetated compost or compost/mulch (seeded or landscaped)	0.55*

* These values were estimated using the SCS TR-55 Peak Discharge and Runoff Calculator at: www.lmnoeng.com/Hydrology/hydrology.htm. This tool lists the Manning's n values for woods: light underbrush at 0.4, and woods: dense underbrush at 0.8. The intent of Option 3 is to amend the soils so that they have surface roughness characteristics equivalent to forested conditions with light underbrush. Option 4 adds a 3-inch top dressing of compost or compost/mulch to simulate a thick forest duff layer, which warrants a higher Manning's n , estimated at 0.55.

Water Depth and Velocity

- The maximum depth of sheet flow through a vegetated filter strip for the runoff treatment design flow rate is 1.0 inch.
- The maximum flow velocity for the runoff treatment design flow velocity is 0.5 feet per second.

Maintain Sheet Flow Conditions

- Sheet flow conditions from the pavement into the vegetated filter strip should be maintained. A no-vegetation zone may help establish and maintain this condition.
- In areas where it may be difficult to maintain sheet flow conditions, consider using aggregate as a flow spreader. It would be placed between the pavement surface and the vegetated filter strip. The aggregate should meet the specifications for crushed surfacing base course listed in Section 9-03.9(3) of the *Standard Specifications* or other aggregate providing the equivalent functionality.
- If there are concerns that water percolated within the aggregate flow spreader may exfiltrate into the highway prism, impervious geotextiles can be used to line the bottom of the aggregate layer.

Vegetated Filter Strip (eastern and western Washington basic vegetated filter strip and eastern Washington CAVFS)

Design Method

1. **Determine the runoff treatment design flow (Q_{wQ}).** In western Washington, the on-line design flow for runoff treatment is the flow rate derived from a continuous model (such as MGSFlood or WWHM) that

calculates the flow rate from the drainage basin below which 91% of the average annual runoff volume occurs. In eastern Washington, the on-line design flow rate is determined based on the peak 5-minute interval for the short-duration design storm, which is the 6-month, 3-hour event. (See Chapter 4 for criteria and hydrologic methods.)

Western Washington flow rate adjustment. In western Washington, design flow rates are calculated using a continuous simulation model. Most of the performance research on vegetated filter strips and biofiltration BMPs has been conducted on vegetated filter strips that used event-based designs. The 91st percentile flow event (as calculated by the continuous model) tends to be less than the estimated 6-month, 24-hour event flow rate in most cases.

The ratio between the 91st percentile flow event and the estimated 6-month, 24-hour flow rate varies with location and percent of impervious area in the modeled drainage basin. When designing vegetated filter strips in western Washington, multiply the on-line water quality design flow rate by the coefficient k^1 given below to apply the 9-minute residence time criterion.

Western Washington Design Flow Coefficient for Biofilters

$$k = 1.41 (P_{72\%, 2\text{-yr.}}) - 0.052 \quad (\text{RT.02-1})$$

where: $P_{72\%, 2\text{-yr.}}$ = 72% of the 2-year, 24-hour precipitation depth (in.)

Note: The 6-month, 24-hour precipitation event can be estimated at 72% of the 2-year, 24-hour precipitation event if 6-month, 24-hour precipitation data are not available.

In eastern Washington, no design flow rate adjustment is needed, since the 6-month, 24-hour flow rate is calculated directly using SBUH-based models such as StormSHED.

The vegetated filter strip design flow rate then becomes:

$$Q_{vfs} = kQ_{wq} \quad (\text{RT.02-2})$$

2. **Calculate the design flow depth at Q_{vfs} .** The design flow depth is calculated based on the length of the vegetated filter strip (same as the length of the pavement edge contributing runoff to the vegetated filter strip) and the lateral slope of the vegetated filter strip parallel to the direction of flow. Design flow depth is calculated using a form of Manning's equation:

$$Q_{vfs} = \frac{1.49}{n} Ly^{5/3} s^{1/2} \quad (\text{RT.02-3})$$

¹ Derived by calculating the linear regression of the ratios of the 91st percentile flow event at 15-minute intervals (determined by MGSFlood) vs. 72% of the 2-year, 24-hour event (determined by the rational method) at each of the major continuously-operating rain gages in western Washington.

- where: Q_{vfs} = vegetated filter strip design flow rate (cfs)
- n = Manning's roughness coefficient. Manning's n can be adjusted by specifying soil and vegetation conditions at the project site, as specified in Table RT.02.1.
- y = design flow depth (ft), also assumed to be the hydraulic radius = 1.0 inch maximum = 0.083 feet
- L = length of vegetated filter strip parallel to pavement edge (ft)
- s = slope of vegetated filter strip parallel to direction of flow (ft/ft).
Vegetated filter strip slopes should be greater than 2% and less than 15%. Vegetated filter strip slopes should be made as shallow as is feasible by site constraints. Gently sloping vegetated filter strips can produce the required residence time for runoff treatment using less space than steeper vegetated filter strips.

Rearranging Equation RT.02-3 to solve for y yields:

$$y = \left[\frac{nQ_{vfs}}{1.49Ls^{1/2}} \right]^{3/5} \quad (\text{RT.02-4})$$

If the calculated depth y is greater than 1 inch, either adjust the vegetated filter strip geometry or use other runoff treatment BMPs.

3. **Calculate the design flow velocity passing through the vegetated filter strip at the vegetated filter strip design flow rate.** The design flow velocity (V_{wQ}) is based on the vegetated filter strip design flow rate, the length of the vegetated filter strip, and the calculated design flow depth from Step 2:

$$V_{wQ} = \frac{Q_{vfs}}{Ly} \quad (\text{RT.02-5})$$

- where: V_{wQ} = design flow velocity (ft/sec)
- y = design flow depth (ft, from Equation RT.02-4)

4. **Calculate the vegetated filter strip width.** The width of the vegetated filter strip is determined by the residence time of the flow through the vegetated filter strip. A 9-minute (540-second) residence time is used to calculate vegetated filter strip width:

$$W = TV_{wQ} = 540V_{wQ} \quad (\text{RT.02-6})$$

- where: W = vegetated filter strip width (ft)
- T = time (sec)
- V_{wQ} = design flow velocity (ft/sec, from Equation RT.02-5)

A minimum width of 8 feet is recommended in order to ensure the long-term effectiveness of the vegetated filter strip will occur.

Narrow Area Vegetated Filter Strip

As previously mentioned, narrow area vegetated filter strips are limited to impervious flow paths less than 30 feet. For flow paths greater than 30 feet, designers should follow the basic vegetated filter strip guidelines. The sizing of a narrow area vegetated filter strip is based on the width of the roadway surface parallel to the flow path of the vegetated filter strip and the lateral slope of the vegetated filter strip.

1. **Determine the width of the roadway surface parallel to the flow path draining to the vegetated filter strip.** Determine the width of the roadway surface parallel to the flow path from the upstream to the downstream edge of the impervious area draining to the vegetated filter strip. This is the same as the width of the paved area.
2. **Determine the average lateral slope of the vegetated filter strip.** Calculate the lateral slope of the vegetated filter strip (parallel to the flow path), averaged over the total length of the vegetated filter strip. If the slope is less than 2%, use 2% for sizing purposes. The maximum lateral slope allowed is 15%.
3. **Determine the required width of the vegetated filter strip.** Use Figure RT.02.2 to size the vegetated filter strip. Locate the width of the impervious surface parallel with the flow path on one of the curves; interpolate between curves as necessary. Next, move along the curve to the point where the design lateral slope of the vegetated filter strip is directly below. Read the vegetated filter strip width to the left on the y-axis. The vegetated filter strip must be designed to provide this minimum width “W” along the entire stretch of pavement draining to it.

Materials

Vegetation

Vegetated filter strips should be planted with grass that can withstand relatively high-velocity flows as well as wet and dry periods. Filter strips may also incorporate native vegetation such as small herbaceous shrubs to make the system more effective in treating runoff and providing root penetration into subsoils, thereby enhancing infiltration. Consult with the Region Landscape Architect or the HQ Roadside and Site Development Section for a selection of grasses and plants suitable for the project site.

Soil Amendments

Refer to Section 5-4.3.2, Soil Amendments.

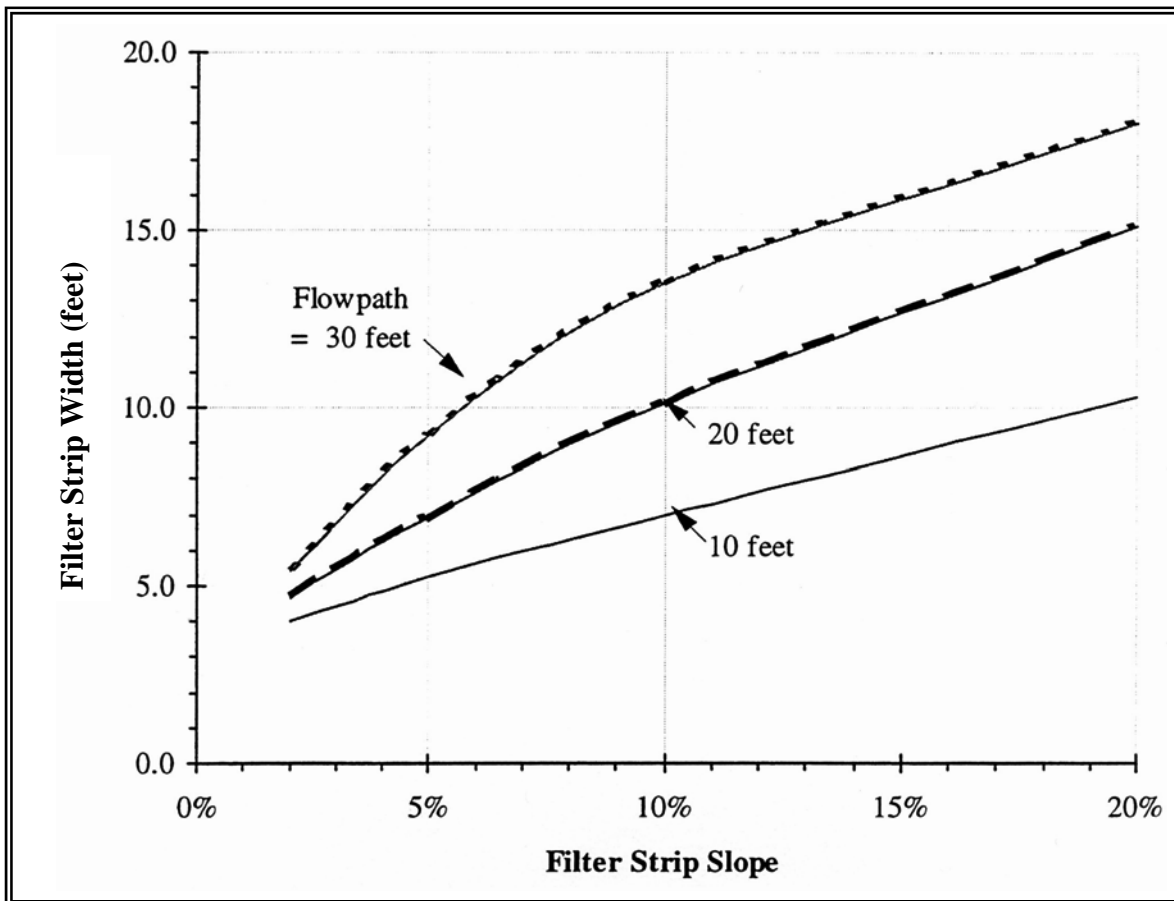

Figure RT.02.2. Narrow area vegetated filter strip design graph.

Site Design Elements

Maintenance Access Roads (Access Requirements)

Access should be provided at the upper edge of all vegetated filter strips to enable maintenance of the gravel flow spreader and permit lawnmower entry to the vegetated filter strip.

RT.04 – Biofiltration Swale

Biofiltration Swale With Spreader Bar on SR 503 in Clark County.

Introduction***General Description***

Biofiltration swales are vegetation-lined channels designed to remove suspended solids from stormwater. The shallow, concentrated flow within these systems allows for the filtration of stormwater by plant stems and leaves. Biological uptake, biotransformation, sorption, and ion exchange are potential secondary pollutant-removal processes (see Figures RT.04.1 and [RT.04.2](#)). Two design procedures are described below. The first is for both eastern and western Washington and the second is only for eastern Washington.

Design Flow Elements***Flows to Be Treated***

Biofiltration swales must be designed to treat the biofiltration design flow rate. Hydrologic methods are presented in Sections 4-3 and 4-4.

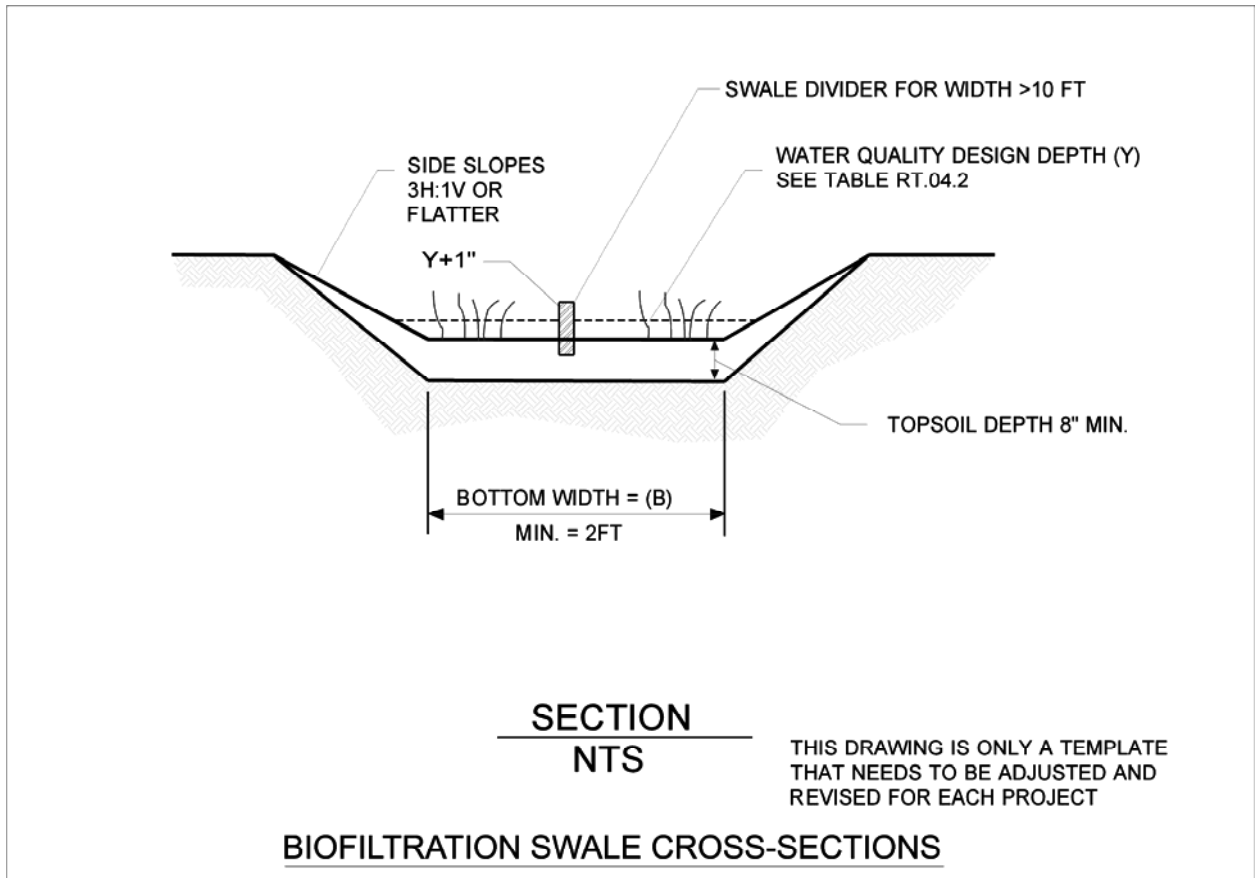

Figure RT.04.2. Biofiltration swale: Cross section.

Structural Design Considerations

Geometry

The following procedure can be used in both eastern and western Washington.

Sizing Procedure

Preliminary Steps (P)

P-1 Determine the runoff treatment design flow rate (Q_{wq}) (see Sections 4-3.1 and 4-4.1).

P-2 Determine the biofiltration design flow rate (Q_{biofil}):

$$Q_{biofil} = kQ_{wq}$$

For western Washington:¹

$$k = 1.41 (P_{72\%, 2\text{-yr.}}) - 0.052 \text{ (for on-line bioswales)}$$

$$k = 2.50 (P_{72\%, 2\text{-yr.}}) - 0.052 \text{ (for off-line bioswales)}$$

where: $P_{72\%, 2\text{-yr}}$ = 72% of the 2-year, 24-hour precipitation depth (in.)

Note: If the 6-month, 24-hour precipitation depth (in.) is known for the project site, that value can be used instead of $P_{72\%, 2\text{-yr}}$.

For eastern Washington:

$$k = 1.0$$

P-3 Establish the longitudinal slope of the proposed biofiltration swale (see Table RT.04.2 for criteria).

P-4 Select a soil and vegetation cover suitable for the biofiltration swale (see Table RT.04.1).

Design Steps (D)

D-1 Select the design depth of flow, y (see Table RT.04.2).

D-2 Select a swale cross-sectional shape. Trapezoidal is preferred, however, rectangular or parabolic cross sections can be used if site-specific constraints so dictate.

¹ The coefficient k is derived by calculating the linear regression of the ratios of the 91st percentile flow event at 15-minute intervals (determined by MGSFlood) vs. 72% of the 2-year, 24-hour event (determined by the rational method) at each of the major continuously-operating rain gages in western Washington and applied to the design flow rate in order to meet the 9-minute residence time criteria.

Table RT.04.1. Flow resistance coefficient in basic, wet, and continuous inflow biofiltration swales.

Soil and Cover	Manning's Coefficient
Grass-legume mix on compacted native soil	0.20
Grass-legume mix on lightly compacted, compost-amended ¹ soil	0.22
Grass-legume mix on lightly compacted, compost-amended ¹ soil with surface roughness features ²	0.35

¹ For information on compost-amended soils, refer to Section 5-4.3.2. (Note that swales do not require a mulch layer and that compost amendments are incorporated into the soil.)

² Acceptable surface roughness features are wattle check dams (Std. Spec. 8-01.3(6)D), gravel filter berms (Std. Spec. 8-01.3(9)B), or compost berms (Std. Plan I-14). These features must be placed every 50 feet (or closer) and should not exceed 1.5 feet in height above finished swale bottom. These features must not be used in place of level spreaders or energy dissipaters.

Table RT.04.2. Biofiltration swale sizing criteria.

Design Parameter	Basic Biofiltration Swale	Wet Biofiltration Swale	Continuous Inflow Biofiltration Swale
Longitudinal slope	0.015–0.050 ¹ feet per foot	0.015 feet or less per foot	Same as basic swale
Maximum velocity	1 foot per second at Q_{biofil}	Same as basic swale	Same as basic swale
Maximum water depth at Q_{biofil} , y	2 inches if swale mowed frequently; 4 inches if mowed infrequently or inconsistently. For dryland grasses in eastern Washington, set depth to 3 inches.	4 inches	Same as basic swale
Manning coefficient at Q_{biofil}	See Table RT.04.1	Same as basic swale	Same as basic swale
Bed width	2–10 feet ²	2–25 feet	Same as basic swale
Freeboard height	1 foot for the peak conveyance flow rate (Q_{convey}) ³	Same as basic swale	Same as basic swale
Minimum length	100 feet	Same as basic swale	Same as basic swale
Maximum side slope (for trapezoidal cross section) ⁴	3H:1V	Same as basic swale	Same as basic swale

¹ For basic biofiltration swale on slopes less than 1.5%, install an underdrain system (see Figure RT.04.3). Underdrain backfill should be covered by at least 4 inches of amended soil or topsoil. Install the low-flow drain 6 inches deep in the soil (see Figure RT.04.4). Underdrains can be made of 6-inch Schedule 40 PVC perforated pipe with 6 inches of drain gravel on the pipe. The gravel and pipe must be enclosed by geotextile fabric. For slopes greater than 5%, install energy dissipaters.

² Multiple parallel swales can be constructed when the calculated swale bottom width exceeds 10 feet.

³ Q_{convey} should be based on the design flow rate of the conveyance system downstream of the biofiltration swale. In general, this is the peak $Q_{25-year}$.

⁴ From swale bed to top of water surface at Q_{biofil} .

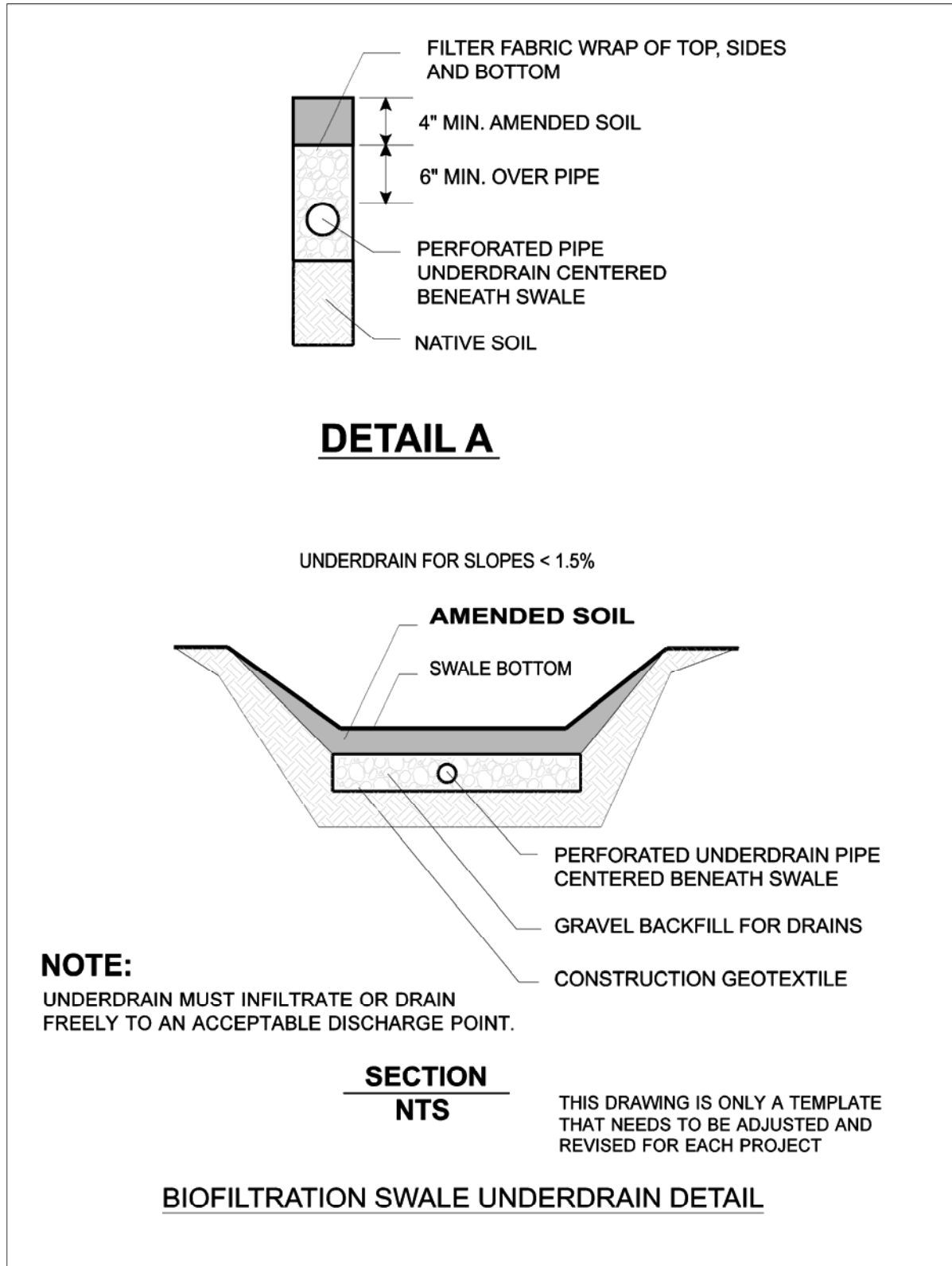
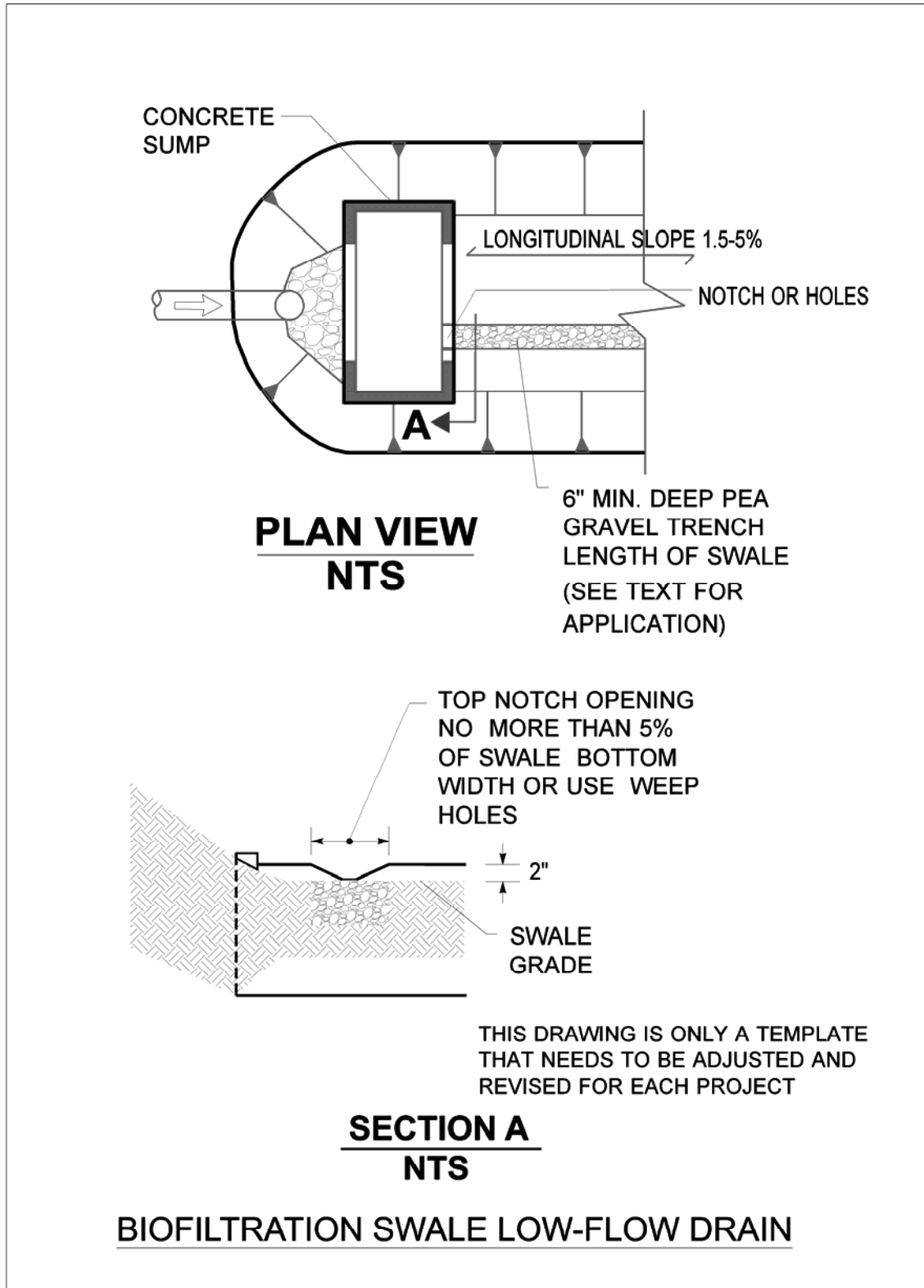

Figure RT.04.3. Biofiltration swale: Underdrain detail.



FILE LOCATION: \Program Files\AutoCAD\2008\Drawings\RT.04.4.dwg

Figure RT.04.4. Biofiltration swale: Low-flow drain detail.

- D-3** Use Manning's equation (RT.04-1) and first approximations relating hydraulic radius and dimensions for the selected swale shape to obtain a value for the width of the biofiltration swale:

$$Q_{biofil} = \frac{1.49AR^{2/3}s^{1/2}}{n} \quad (\text{RT.04-1})$$

where: Q_{biofil} = runoff treatment design flow rate (cfs)

A = wetted area (ft²)

R = hydraulic radius (ft)

s = longitudinal slope of swale (ft/ft)

n = Manning's coefficient (see Table RT.04.1)

To solve for the cross-sectional shape of the swale, use one of the following methods:

Method 1

Solve the implicit equation $AR^{0.67} = Q_{biofil}n / (1.49s^{0.5})$ to determine bed width, b , or width of water surface, T (for parabolic or triangular cross sections), for the selected cross-sectional geometry. Use Figure RT.04.5 to substitute for A and R for the selected cross-sectional geometry. The variables Q_{biofil} , y , s , and n are all known values. The equation should then contain only a single unknown (b or T).

Method 2

Use nomographs relating $(Q_{biofil}n) / (1.49s^{0.5})$ for trapezoidal channels with known side slopes (z) to determine b for a given y (see Figure RT.04.6 for $z = 3$ and Figure RT.04.7 for $z = 4$).

Method 3

For a trapezoidal swale that is flowing very shallow, the hydraulic radius, R , can be set equal to the depth of flow. Using this assumption, the equation in Method 1 can be changed to:

$$b = [(Q_{biofil}n) / (1.49y^{1.67}s^{0.5})] - zy$$

Note: If any of these methods produce a value for b or T of less than 2 feet, then set bed width to 2 feet.

- D-4** Compute A at Q_{biofil} by using the equations in Figure RT.04.5.

D-5 Compute the flow velocity at Q_{biofil} :

$$V_{biofil} = \frac{Q_{biofil}}{A} \quad (\text{RT.04-2})$$

where: V_{biofil} = flow velocity at Q_{biofil} (ft/sec)

If $V_{biofil} > 1.0$ ft/sec, increase width (b or T) or investigate ways to reduce Q_{WQ} and then repeat Steps D-3, D-4, and D-5 until $V_{biofil} \leq 1.0$ ft/sec. A velocity greater than 1.0 ft/sec was found to flatten grasses, thus reducing filtration.



D-6 Compute the swale length, L (ft):

$$L = V_{biofil} t \text{ (60 sec/min)}$$

where: t = hydraulic residence time (9 minutes for basic biofiltration swales)

D-7 If there is not sufficient space for the biofiltration swale, consider the following solutions:

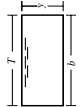
1. Divide the site drainage to flow to multiple biofiltration swales.
2. Use infiltration or dispersion to provide lower Q_{biofil} .
3. Alter the design depth of flow if possible (see Table RT.04.2).
4. Reduce the developed surface area to gain space for the biofiltration swale.
5. Reduce the longitudinal slope by meandering the biofiltration swale.
6. Nest the biofiltration swale within or around another stormwater BMP.

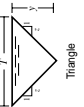
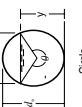
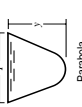
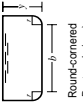
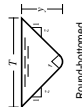
Section	Area A	Wetted perimeter P	Hydraulic radius R	Top width W	Hydraulic depth D	Section factor Z
 Rectangle	by	$b + 2y$	$\frac{by}{b + 2y}$	b	y	$by^{1.5}$
 Trapezoid	$(b + zy)y$	$b + 2y\sqrt{1 + z^2}$	$\frac{(b + zy)y}{b + 2y\sqrt{1 + z^2}}$	$b + 2zy$	$\frac{(b + zy)y}{b + 2zy}$	$\frac{[(b + zy)y]^{1.5}}{\sqrt{b + 2zy}}$
 Triangle	zy^2	$2y\sqrt{1 + z^2}$	$\frac{zy}{2\sqrt{1 + z^2}}$	$2zy$	$1/2y$	$\frac{\sqrt{2}zy^{2.5}}{2}$
 Circle	$1/8(\theta - \sin\theta)d_c^2$	$1/2\theta d_c$	$1/4(1 - \frac{\sin\theta}{\theta})d_c$	$(\sin(1/2\theta)d_c)$ or $2\sqrt{y}(d_c - y)$	$1/8(\frac{\theta - \sin\theta}{\sin(1/2\theta)})d_c$	$\frac{\sqrt{2}(\theta - \sin\theta)^{1.5}}{32(\sin(1/2\theta))^{0.5}}d_c^{2.5}$
 Parabola	$2/3Ty$	$T + \frac{8y^2}{3T}$ *	$\frac{2T^2y}{3T^2 + 8y^2}$ *	$3A$ $2y$	$2/3y$	$2/9\sqrt{6}Ty^{1.5}$
 Round-cornered Rectangle (y>r)	$(\frac{\pi}{2} - 2)r^2 + (b + 2r)y$	$(\pi - 2)r + b + 2y$	$\frac{(\frac{\pi}{2} - 2)r^2 + (b + 2r)y}{(\pi - 2)r + b + 2y}$	$b + 2r$	$\frac{(\frac{\pi}{2} - 2)r^2}{(b + 2r)} + y$	$\frac{[(\frac{\pi}{2} - 2)r^2 + (b + 2r)y]^{1.5}}{\sqrt{b + 2y}}$
 Round-bottomed Triangle	$\frac{T^2}{4z} - \frac{r^2}{z}(1 - z\cot^{-1}z)$	$\frac{T}{z}\sqrt{1 + z^2} - \frac{2r}{z}(1 - z\cot^{-1}z)$	$\frac{A}{P}$	$2[z(y - r) + r\sqrt{1 + z^2}]$	$\frac{A}{T}$	$A\sqrt{\frac{A}{T}}$

*Satisfactory approximation for the interval $0 < x \leq 1$, where $x = 4y/T$. When $x > 1$, use the exact expression $P = (\frac{T}{2})[\sqrt{1 + x^2} + 1/4 \ln(x + \sqrt{1 + x^2})]$

Figure RT.04.5. Geometric elements of common cross sections.

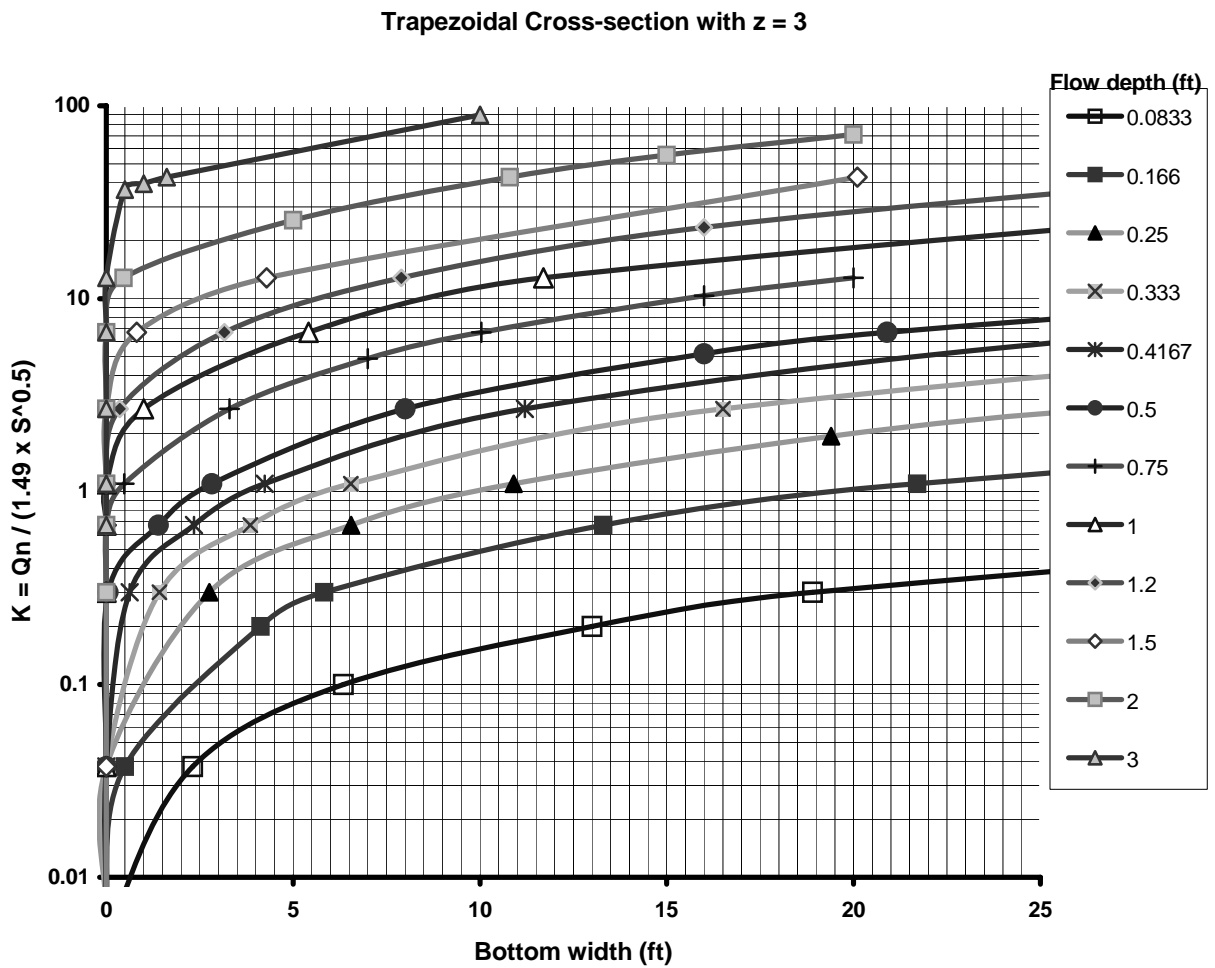

Figure RT.04.6. Open channel flow parameter, $Qn/(1.49 s^{0.5})$, versus bottom width (b) at different flow depths ($z = 3$).

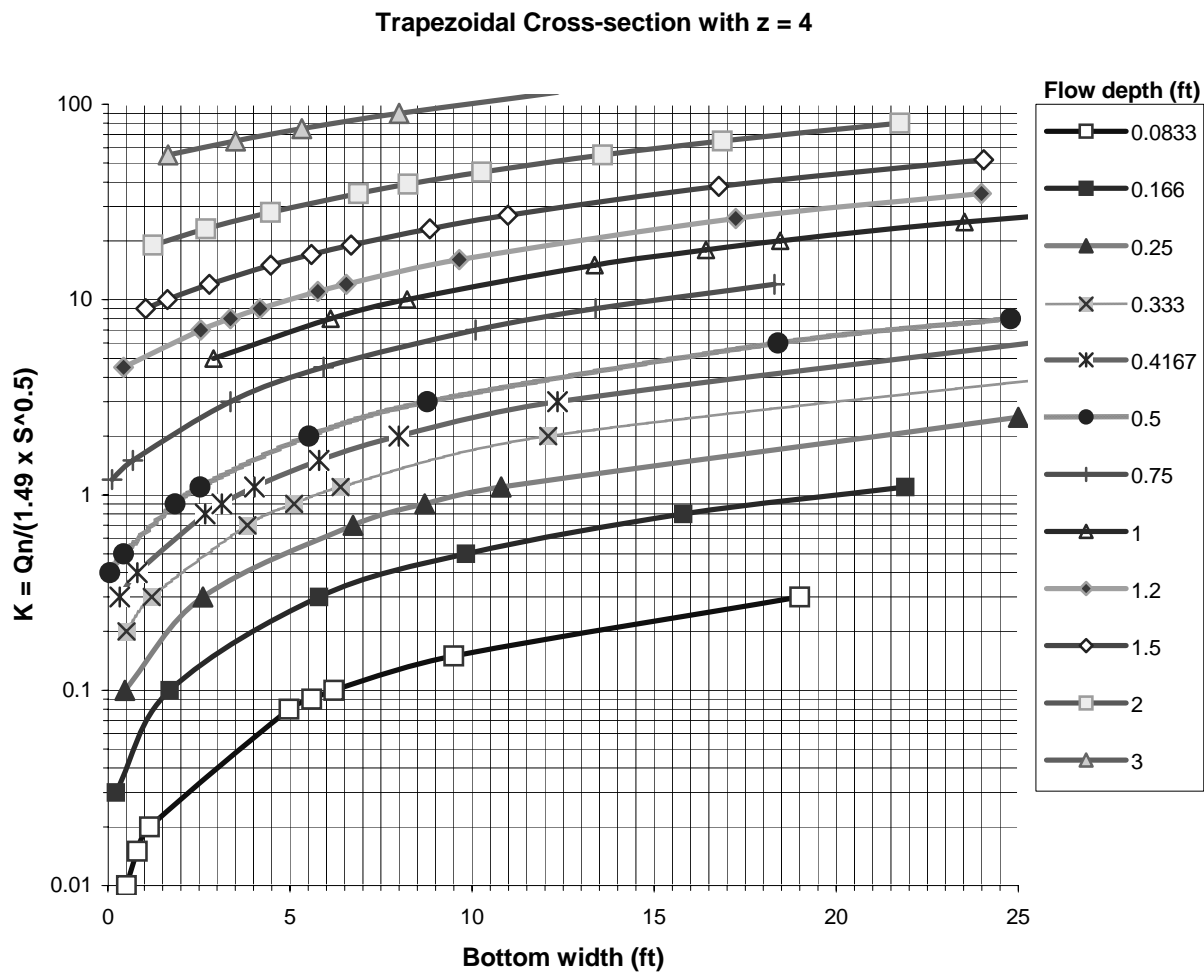

Figure RT.04.7. Open channel flow parameter, $Qn/(1.49 s^{0.5})$, versus bottom width (b) at different flow depths ($z = 4$).

Freeboard Check (FC)

A freeboard check must be performed for the combination of highest expected flow and least vegetation coverage and height. For western Washington, the highest expected flow rate (Q_{convey}) is 100-year, return frequency flow using 15-minute time steps using an approved continuous runoff model. Until MGSFlood peak flow rates in 15-minute time steps are available, the designer can use the MGSFlood 100-year hourly peak flow rates multiplied by a factor of 1.6 to approximate the peak flow in 15-minute time steps. The freeboard check is not necessary for biofiltration swales that are located off-line from the primary conveyance and detention system (that is, when flows in excess of Q_{biofil} bypass the biofiltration swale). Off-line is the preferred configuration of biofiltration swales.

Note: Use the same units as in the biofiltration swale design steps.

- FC-1** Unless runoff at rates higher than Q_{biofil} will bypass the biofiltration swale, perform a freeboard check for Q_{convey} .
- FC-2** Select the lowest possible roughness coefficient for the biofiltration swale (assume $n=0.03$).
- FC-3** Again, use the implicit equation $AR^{0.67} = Q_{convey}n / (1.49s^{0.5})$ (see Figure RT.04.5) and with a known b (or T), solve for depth, y . Select the lowest y that provides a solution. For trapezoidal swales, Figures RT.04.6 and RT.04.7 can be used directly. (Note that in the case of a parabola, the equation must be solved implicitly for two unknowns.)
- FC-4** Ensure swale depth exceeds flow depth at Q_{convey} by a minimum of 1 foot (1-foot-minimum freeboard).

The following procedure can only be used in eastern Washington.

Sizing Procedure

Preliminary Steps (P)

- P-1** Determine the runoff treatment design flow rate (Q_{wq}); this is also the biofiltration design flow rate (Q_{biofil}) (see Section 4-4.1).
- P-2** Determine the slope of the biofiltration swale (this will be somewhat dependent on where the swale is placed). The slope should be at least 1% and shall be no steeper than 5%. When slopes less than 2% are used, the need for underdrainage must be evaluated.
- P-3** Select a swale shape. Trapezoidal is the most desirable shape; however, rectangular and triangular shapes can be used. The remainder of the design process assumes that a trapezoidal shape has been selected.
- P-4** Use Manning's equation to estimate the bottom width of the biofiltration swale. Manning's equation for English units is as follows:

$$Q_{biofil} = (1.486 AR^{0.667} s^{0.5}) / n$$

where: Q_{biofil} = runoff treatment design flow rate (cfs)

A = cross-sectional area of flow (ft²)

R = hydraulic radius of flow cross section (ft)

s = longitudinal slope of biofiltration swale (ft/ft)

n = Manning's roughness coefficient (use $n = 0.20$ for typical biofiltration swale with turf/lawn vegetation and $n = 0.30$ for biofiltration swale with less dense vegetation such as meadow or pasture)

For a trapezoid, this equation cannot be directly solved for bottom width. However, for trapezoidal channels that are flowing very shallow, the hydraulic radius can be set equal to the depth of flow. Using this assumption, the equation can be altered to:

$$B = (((n/1.486) Q_{biofil}) / (y^{1.667} s^{0.5})) - zy$$

where: B = bottom width of the swale

y = depth of flow

z = the side slope of the biofiltration swale in the form of $z:1$

Typically, the depth of flow for turf grass is selected to be 4 inches. For dryland grasses, the depth of flow should be set to 3 inches. It can be set lower, but doing so will increase the bottom width. Sometimes when the flow rate is very low, the equation listed above will generate a negative value for B . Since it is not possible to have a negative bottom width, the bottom width should be set to 1 foot when this occurs.

Biofiltration swales are limited to a maximum bottom width of 10 feet. If the required bottom width is greater than 10 feet, parallel swales should be used in conjunction with a device that splits the flow and directs the proper amount to each swale.

P-5 Calculate the cross-sectional area of flow for the given channel using the calculated bottom width and the selected side slopes and depth.

P-6 Calculate the velocity of flow in the channel using:

$$V = Q_{biofil}/A$$

If V is less than or equal to 1 ft/sec, the biofiltration swale will function correctly with the selected bottom width. Proceed to P-7.

If V is greater than 1 ft/sec, the biofiltration swale will not function correctly. Increase the bottom width, recalculate the depth using Manning's equation, and return to P-5.

- P-7** Select a location where a biofiltration swale with the calculated width and a length of 200 feet will fit. If a length of 200 feet is not possible, the width of the biofiltration swale must be increased so that the area of the biofiltration swale is the same as if a 200-foot length had been used.
- P-8** Select a vegetation cover suitable for the site. Consult Table RT.04.1 or the local NRCS office or the County Extension Service for guidance.
- P-9** Using Manning's equation, find the depth of flow (typically $n=0.04$ during Q_{biofil}). The depth of the channel shall be 1 foot deeper than the depth of flow. Check to determine that shear stresses do not cause erosion; the velocity needs to stay below 2 ft/sec.

Design Steps (D)

- D-1** Though the actual dimensions for a specific site may vary, the swale should generally have a length of 200 feet. The maximum bottom width is typically 10 feet. The depth of flow should not exceed 4 inches during the design storm. The flow velocity should not exceed 1ft/sec.
- D-2** The channel slope should be at least 1% and no greater than 5%.
- D-3** The swale can be sized as a treatment facility for Q_{biofil} .
- D-4** The ideal cross section of the swale should be a trapezoid. The side slopes should be no steeper than 3H:1V.
- D-5** Roadside ditches should be regarded as significant potential biofiltration sites and should be utilized for this purpose whenever possible.
- D-6** If flow is to be introduced through curb cuts, place pavement slightly above the biofiltration swale elevation. Curb cuts should be at least 12 inches wide to prevent clogging.
- D-7** Biofiltration swales must be vegetated in order to provide adequate treatment of runoff.
- D-8** It is important to maximize water contact with vegetation and the soil surface. For general purposes, select fine, close-growing grasses (or other vegetation) that can withstand prolonged periods of wetting as well as prolonged dry periods (to minimize the need for irrigation). Consult the local NRCS office or the County Extension Service for specific vegetation selection recommendations.

- D-9** Biofiltration swales should generally not receive construction-stage runoff. If they do, presettling of sediments should be provided. (See BMPs 6A-2.30, Sediment Trap, and 6A-2.31, Temporary Sediment Pond, in Appendix 6A – Best Management Practices.) Such biofilters should be evaluated for the need to remove sediments and restore vegetation following construction. The maintenance of presettling basins or sumps is critical to their effectiveness as pretreatment devices.
- D-10** If possible, divert runoff (other than necessary irrigation) during the period of vegetation establishment. Where runoff diversion is not possible, protect graded and seeded areas with suitable erosion control measures.

Site Design Elements

- Install level spreaders at the head of the biofiltration swale in swales 6 feet or greater in bottom width. Include sediment cleanouts at the head of the swale as needed (see Section 5-4.3.5 for level spreader options). It is recommended that swales with a bottom width in excess of 6 feet or greater have a level spreader for every 50 feet of swale length.
- Use energy dissipaters for swales on longitudinal slopes exceeding 2.5%.
- Specify that topsoil extends to at least an 8-inch depth unless an underdrain system is needed (see Table RT.04.2).
- To improve infiltration on longitudinal slopes less than 1.5%, ensure the swale bed material contains a sand percentage greater than 70% (greater than 70% by weight retained on the No. 40 sieve) before organic amendments are added.
- If groundwater contamination is a concern, seal the bed or underdrain area with either a treatment liner or a low-permeability liner that is appropriate for site conditions. (See Section 5-4.3.3 for additional information on these liner types.)

Landscaping (Planting Considerations)

- Consult with the Region Landscape Architect or the HQ Roadside and Site Development Section to determine plants for use in the basic biofiltration swale.
- Select fine, turf-forming grasses where moisture is appropriate for growth.
- If possible, perform final seeding of the swale during the seeding windows specified in the *Standard Specifications*. Supplemental irrigation may be required depending on seeding and planting times.
- Plant wet-tolerant species in the fall.

- Use only sod specified by the Region Landscape Architect.
- Stabilize soil areas upslope of the biofiltration swale to prevent erosion and excessive sediment deposition.
- Apply seed via hydroseeder or broadcaster.

Construction Criteria

- Do not put the biofiltration swale into operation until areas of exposed soil in the contributing drainage catchment have been sufficiently stabilized.
- Keep effective erosion and sediment control measures in place until the swale vegetation is established.
- Avoid over-compaction during construction.
- Grade biofiltration swales to attain uniform longitudinal and lateral slopes.

RT.05 – Wet Biofiltration Swale

Introduction

General Description

A *wet biofiltration swale* is a variation of a basic biofiltration swale for use where the longitudinal slope is slight, water tables are high, or continuous base flow is likely to result in saturated soil conditions. Where saturation exceeds about two continuous weeks, typical grasses die; thus, vegetation specifically adapted to saturated soil conditions is needed. This type of vegetation in turn requires modification of several of the design parameters for the basic biofiltration swale to remove low concentrations of pollutants such as total suspended solids (TSS), heavy metals, nutrients, and petroleum hydrocarbons.

Applications and Limitations

Wet biofiltration swales are applied where a basic biofiltration swale is desired but not allowed or advisable because of one or more of the following conditions:

- The swale is on till soils and is downstream of a detention pond providing flow control
- Saturated soil conditions are likely because of seeps, high groundwater, or base flows on the site
- Longitudinal slopes are slight (generally less than 1.5%) and ponding is likely

Design Flow Elements

Flows to Be Treated

Wet biofiltration swales must be designed to treat the runoff treatment flow rate discussed in Section 3-3.5 under Minimum Requirement 5. Hydrologic methods are presented in Sections 4-3 and 4-4.

Overflow or Bypass

To accommodate flows exceeding the water quality flow rate, the following two design options are available:

1. A high-flow bypass can be installed for flows greater than the runoff treatment design flow to protect wetland vegetation from damage. Unlike grass, wetland vegetation does not quickly regain an upright attitude after being flattened by high flows. New growth, usually from the base of the plant and often taking several weeks, is required for the grass to regain its upright form. The bypass may be an open channel parallel to the wet biofiltration swale.
2. Alternatively, swale bottom width may be tripled to accommodate high flows. The following features must be included:
 - An energy dissipater and level spreader must be set at the head of the swale to ensure equal distribution of influent and reduce the potential for scour. Gravel filter berms (Standard Specification 8-01.3[9]B) must be placed every 30 feet across the full width of the swale. The minimum required swale length should not include the length occupied by gravel filter berms.
 - If the calculated width to convey high flows exceeds 25 feet, then a high flow channel with a bed elevation 0.5 feet above the swale depth can be constructed. The high-flow channel can be either planted or rock-lined.

Structural Design Considerations

Geometry

Use the same design approach as for basic biofiltration swales (see BMP RT.04), except add the following:

Extended wet season flow adjustment. If the swale is downstream of a detention pond providing flow control, multiply the treatment area (bottom width times length) of the swale (as determined by the design steps listed in BMP RT.04) by 2 and readjust the swale length or width to provide an equivalent area. Maintain a 5:1 length-to-width ratio.

Intent: The treatment area of swales following detention ponds needs to be increased because of the differences in vegetation established in a constant flow environment. Flows following detention are much more prolonged. These prolonged flows result in more stream-

like conditions than are typical for other wet biofilter situations. Because vegetation growing in streams is often less dense, an increase in treatment area is needed to ensure equivalent pollutant removal is achieved in extended flow situations.

Swale geometry. Use the same geometry specified for basic biofiltration swales (see BMP RT.04), except for the following modifications:

- The bottom width may be increased to 25 feet maximum, but a length-to-width ratio of 5:1 must be maintained (see Figure RT.05.1). No longitudinal dividing berm is needed. Note: The minimum swale length is 100 feet.
- If longitudinal slopes are greater than 2%, the wet swale must be stepped so that the slope within the stepped sections averages 2% or less. Steps may be made of retaining walls, log check dams, short riprap sections, or similar structures. Steps must be designed to prevent scour on the downstream side of the step. No underdrain or low-flow drain is required.

Water depth and base flow. Use the same criteria specified for basic biofiltration swales (see BMP RT.04), except that the design water depth must be 4 inches for all wetland vegetation selections and no underdrains or low-flow drains are required.

Flow velocity, energy dissipation, and flow spreading. Use the same criteria specified for basic biofiltration swales (see BMP RT.04), except flow spreaders are not needed.

Site Design Elements

Landscaping (Planting Considerations)

Use the same design considerations specified for basic biofiltration swales (see BMP RT.04), except for the following modifications:

- Select acceptable plants for western Washington sites from the list shown in Table RT.05.1. In general, it is best to plant several species to increase the likelihood that at least some of the selected species will find growing conditions favorable.
- A wetland seed mix may be applied by hydroseeding, but if coverage is poor, planting rootstock or nursery stock is required. Poor coverage is considered to be more than 30% bare area through the upper two-thirds of the swale after four weeks.

Construction Considerations

Use the same construction considerations specified for basic biofiltration swales (see BMP RT.04).

HEC Dwg File: \$\$(name.dwgname) Layout: \$\$(name.ctb) Last Edited: \$\$(time.\$(name.\$(date)))\\\$\$(root.\$(name.\$(date)))\\\$\$(name.dwgname)

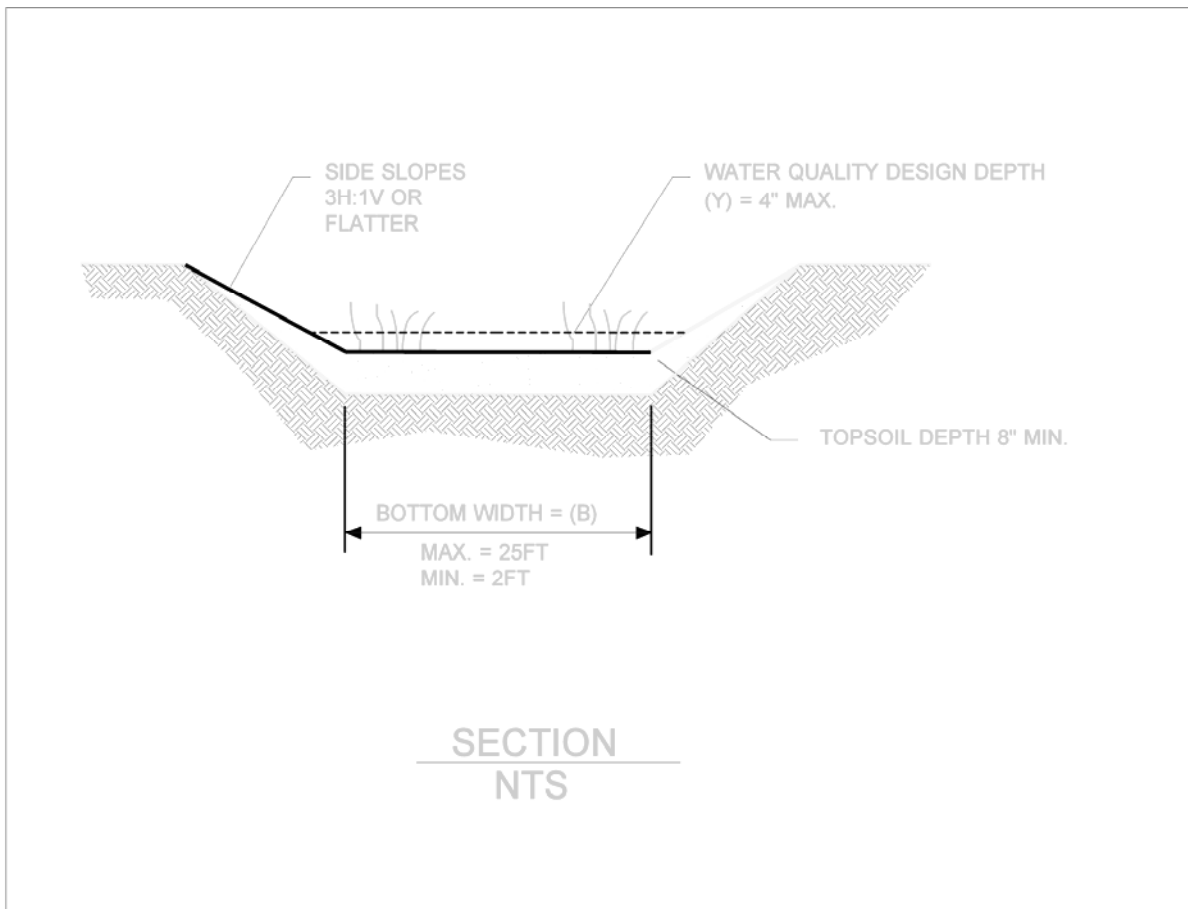

Figure RT.05.1. Wet biofiltration swale: Cross section.

Table RT.05.1. Recommended plants for wet biofiltration swales in western Washington.

Common Name	Scientific Name
Shortawn foxtail	<i>Alopecurus aequalis</i>
Water foxtail	<i>Alopecurus geniculatus</i>
Spike rush	<i>Eleocharis spp.</i>
Slough sedge*	<i>Carex obnupta</i>
Sawbeak sedge	<i>Carex stipata</i>
Sedge	<i>Carex spp.</i>
Western mannagrass	<i>Glyceria occidentalis</i>
Velvetgrass	<i>Holcus mollis</i>
Slender rush	<i>Juncus tenuis</i>
Watercress*	<i>Rorippa nasturtium-aquaticum</i>
Water parsley*	<i>Oenanthe sarmentosa</i>
Hardstem bulrush	<i>Scirpus acutus</i>
Small-fruited bulrush	<i>Scirpus microcarpus</i>

* Good choice for swales with significant periods of flow, such as those downstream of a detention facility.

Note: Cattail (*Typha latifolia*) is not appropriate for most wet swales because of its very dense and clumping growth habit that prevents water from filtering through the clump.

RT.06 – Continuous Inflow Biofiltration Swale

Introduction

General Description

In situations where water enters a biofiltration swale continuously along the side slope rather than discretely at the head, a different design approach—the *continuous inflow biofiltration swale*—is needed (see Figure RT.06.1). The basic swale design is modified by increasing swale length to achieve an equivalent average hydraulic residence time.

Applications and Limitations

A continuous inflow biofiltration swale is used when inflows are not concentrated, such as locations along the shoulder of a road without curbs. This design may also be used where frequent, small-point flows enter a swale, such as through curb inlet ports spaced at intervals along a road or from a parking lot with frequent curb cuts. In general, no inlet port should carry more than about 10% of the flow.

A continuous inflow swale is not appropriate where significant lateral flows enter a swale at some point downstream from the head of the swale. In this situation, the swale width and length must be recalculated from the point of confluence to the discharge point in order to provide adequate treatment for the increased flows.

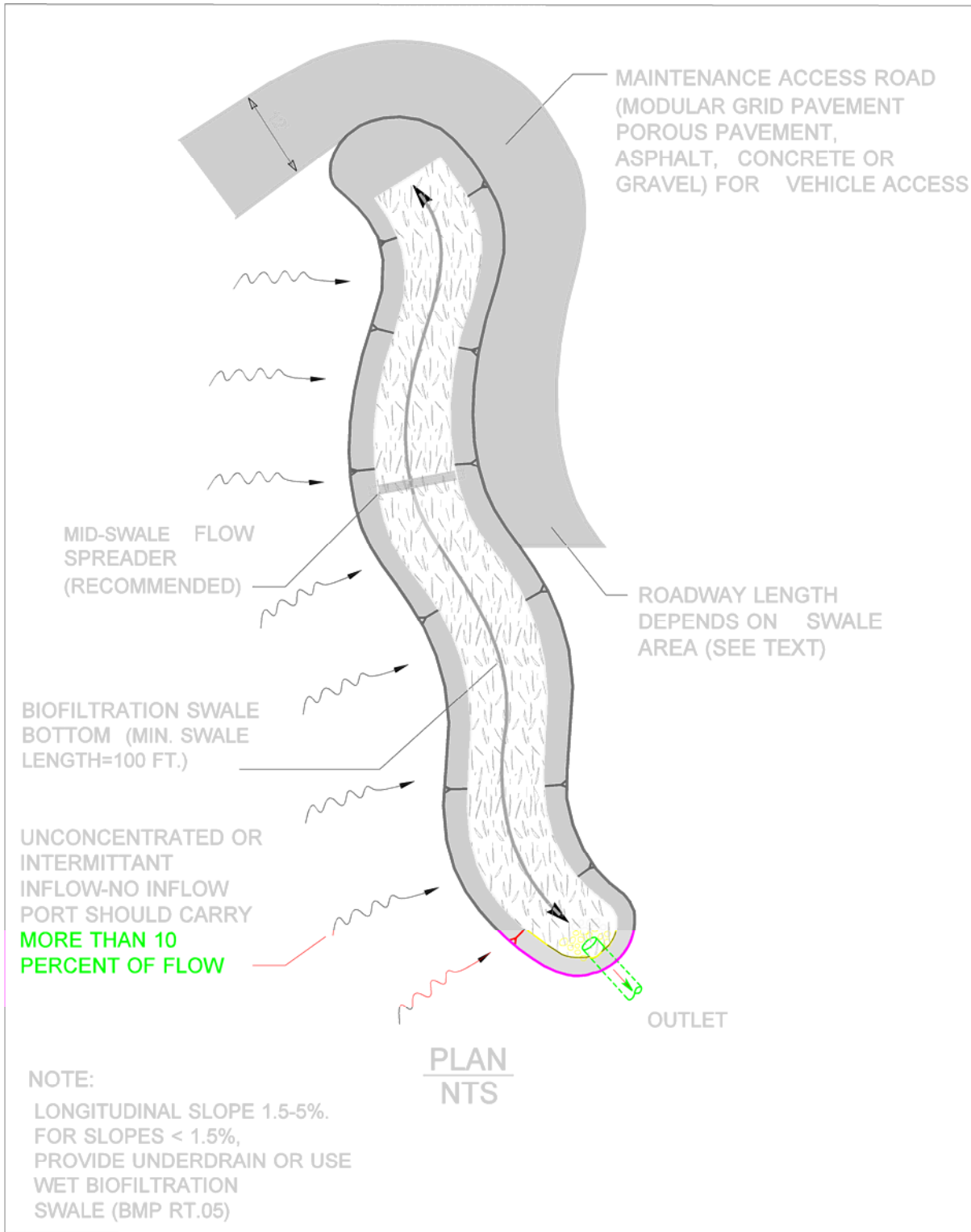

Figure RT.06.1. Continuous inflow biofiltration swale: Plan view.

Structural Design Considerations

Use the same considerations specified for BMP RT.04 (biofiltration swale), except for the following:

- For the design flow, include runoff from the pervious side slopes draining to the swale along the entire swale length.
- If only a single design flow is used, use the flow rate at the outlet. The goal is to achieve an average residence time through the swale of 9 minutes. Assuming an even distribution of inflow into the side of the swale, double the hydraulic residence time to a minimum of 18 minutes.

Determine Q_{biofil} as shown in Step P-2 of the basic biofiltration swale (see BMP RT.04) criteria.

- For continuous inflow biofiltration swales, plant interior side slopes above the runoff treatment design elevation in grass. A typical lawn seed mix or the biofiltration seed mixes are acceptable. Landscape plants or groundcovers other than grass generally should not be used between the runoff inflow elevation and the bottom of the swale.

Intent: The use of grass on interior side slopes reduces the chance of soil erosion and transfer of pollutants from landscape areas to the biofiltration treatment area.

After the cross-sectional size of the biofiltration swale is determined using Q_{biofil} , complete the following steps. This is to account for the hydraulic residence time of flow moving through the vegetated side slopes (3H:1V or shallower and slope length >5 feet) at various points along the length of the swale.

1. Break the drainage basin of the swale into areas so that no area contributes more than 20% of the flow. Include only those areas that discharge sheet flow to the vegetated side slopes and biofiltration swale.
2. Determine the velocity of flows through each vegetated side slope, $V_{n,ss}$ (ft/sec), for each of the contributing areas by completing Steps 1 through 3 of the vegetated filter strip design methodology (see BMP RT.02).
3. Determine the hydraulic residence time within each vegetated side slope, t_{ss} (sec), for each area using:

$$L_{n,ss}/V_{n,ss} = t_{n,ss}$$

where: $L_{n,ss}$ = length of vegetated side slope of the nth swale subbasin (ft)

4. Determine the weighted mean hydraulic residence time, $t_{mean,ss}$, for *all flows* passing through vegetated side slopes using:

$$[Q_1(t_{ss,1}) + Q_2(t_{ss,2}) + \dots + Q_n(t_{ss,n})] / Q_{total,ss} = t_{mean,ss}$$

where: Q_n = flow rate for n^{th} contributing area (cfs)

$Q_{total,ss}$ = total flow that passes through all of the vegetated side slopes (cfs)

5. Multiply $t_{mean,ss}$ by R

where: $t_{mean,ss} \times R = t_{adj}$

R = $Q_{total,ss} / Q_{biofil}$

Q_{biofil} = total runoff treatment flow rate as determined in Step P-2 of the basic biofiltration swale (see BMP RT.04) criteria

6. If the head of the swale is located downstream of the last contributing vegetated side slope section, subtract t_{adj} from 540 seconds (= 9 minutes) to determine the t_{design} . If the swale is located along the entire toe of the contributing vegetated side slope, subtract t_{adj} from 1080 seconds (= 18 minutes) to determine t_{design} . Note: In the latter case, the swale must be at least as long as the contributing vegetated side slopes.
7. Using the downstream flow rate (Q_{biofil}), determine the velocity through the swale and use t_{design} calculated in Step 6 to determine the total swale length required. Make any necessary adjustments to ensure the criteria in Table RT.04.2 are met.

RT.07 – Media Filter Drain (previously referred to as the Ecology Embankment)

Media Filter Drain Along SR 167 in King County.

Introduction***General Description***

The media filter drain (MFD), previously referred to as the *ecology embankment*, is a linear flow-through stormwater runoff treatment device that can be sited along highway side slopes (conventional design) and medians (dual media filter drains), borrow ditches, or other linear depressions. Cut-slope applications may also be considered. The media filter drain can be used where available right of way is limited, sheet flow from the highway surface is feasible, and lateral gradients are generally less than 25% (4H:1V). The media filter drain has a General Use Level Designation (GULD) for basic, enhanced, and phosphorus treatment. Updates/changes to the use-level designation and any design changes will be posted in the *Postpublication Updates* section of the HRM Resource web page.

Media filter drains (MFDs) have four basic components: a gravel no-vegetation zone, a grass strip, the MFD mix bed, and a conveyance system for flows leaving the MFD mix. This conveyance system usually consists of a gravel-filled underdrain trench or a layer of crushed surfacing base course (CSBC). This layer of CSBC must be porous enough to allow treated flows to freely drain away from the MFD mix.

Typical MFD configurations are shown in Figures RT.07.1, RT.07.2, and RT.07.3.

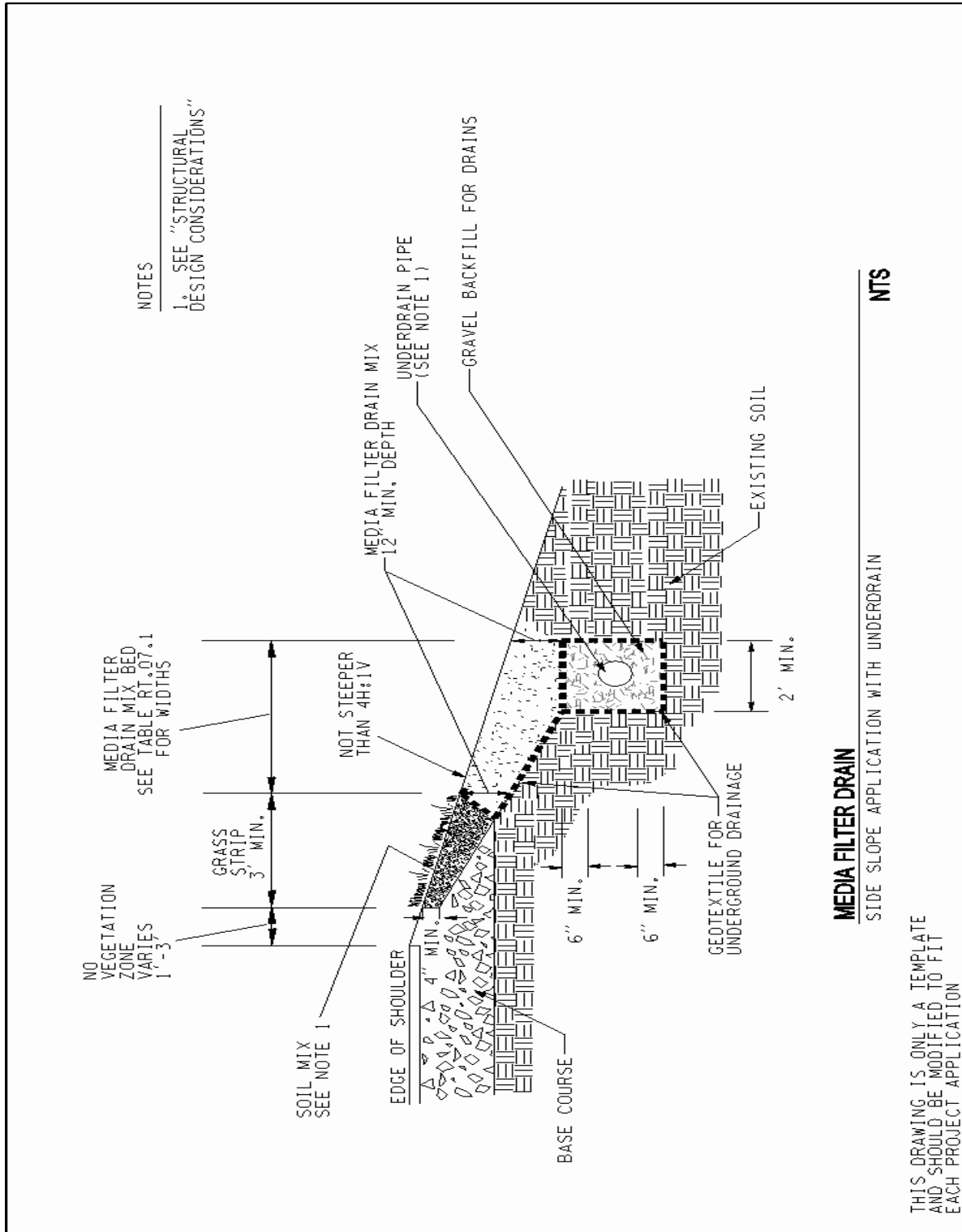

Figure RT.07.1. Media filter drain: Cross section.

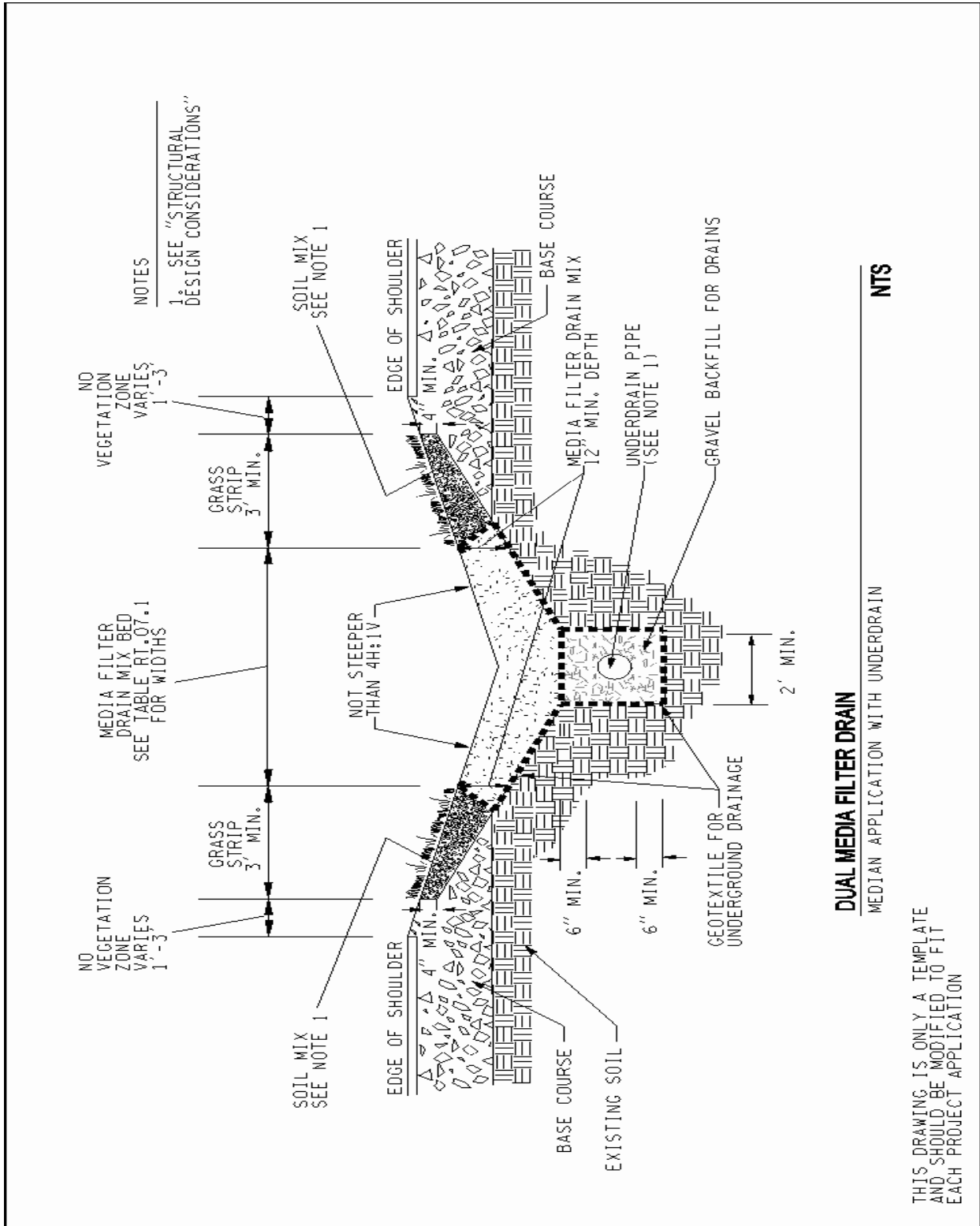

Figure RT.07.2. Dual media filter drain: Cross section.

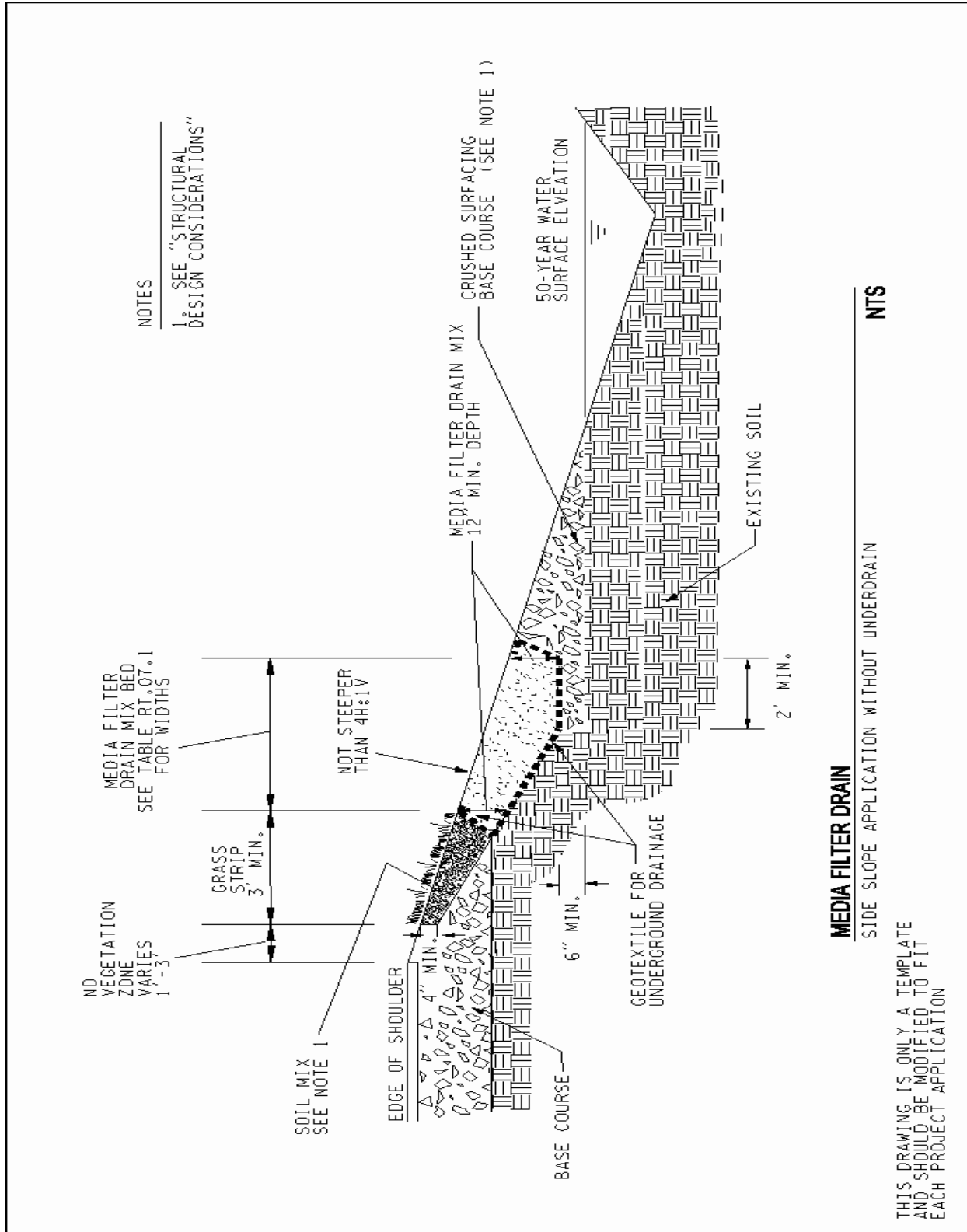

Figure RT.07.3. Media filter drain without underdrain trench.

Functional Description

The media filter drain removes suspended solids, phosphorus, and metals from highway runoff through physical straining, ion exchange, carbonate precipitation, and biofiltration.

Stormwater runoff is conveyed to the media filter drain via sheet flow over a vegetation-free gravel zone to ensure sheet dispersion and provide some pollutant trapping. Next, a grass strip, which may be amended with compost, is incorporated into the top of the fill slope to provide pretreatment, further enhancing filtration and extending the life of the system. The runoff is then filtered through a bed of porous, alkalinity-generating granular medium—the media filter drain mix. Media filter drain mix is a fill material composed of crushed rock (sized by screening), dolomite, gypsum, and perlite. The dolomite and gypsum additives serve to buffer acidic pH conditions and exchange light metals for heavy metals. Perlite is incorporated to improve moisture retention, which is critical for the formation of biomass epilithic biofilm to assist in the removal of solids, metals, and nutrients. Treated water drains from the media filter drain mix bed into the conveyance system below the media filter drain mix. Geotextile lines the underside of the media filter drain mix bed and the conveyance system.

The underdrain trench is an option for hydraulic conveyance of treated stormwater to a desired location, such as a downstream flow control facility or stormwater outfall. The trench's perforated underdrain pipe is a protective measure to ensure free flow through the media filter drain mix. It may be possible to omit the underdrain pipe if it can be demonstrated that the pipe is not necessary to maintain free flow through the media filter drain mix and underdrain trench.

It is critical to note that water should sheet flow across the media filter drain. Channelized flows or ditch flows running down the middle of the dual media filter drain (continuous off-site inflow) should be minimized.

Applications and Limitations

In many instances, conventional runoff treatment is not feasible due to right of way constraints (such as adjoining wetlands and geotechnical considerations). The media filter drain and the dual media filter drain designs are runoff treatment options that can be sited in most right of way confined situations. In many cases, a media filter drain or a dual media filter drain can be sited without the acquisition of additional right of way needed for conventional stormwater facilities or capital-intensive expenditures for underground wet vaults.

Applications

Media Filter Drains

The media filter drain can achieve basic, phosphorus, and enhanced water quality treatment. Since maintaining sheet flow across the media filter drain is required for its proper function, the ideal locations for media filter drains in highway settings are highway side slopes or other long, linear grades with lateral side slopes less than 4H:1V and longitudinal slopes no steeper

than 5%. As side slopes approach 3H:1V, without design modifications, sloughing may become a problem due to friction limitations between the separation geotextile and underlying soils. The longest flow path from the contributing area delivering sheet flow to the media filter drain should not exceed 150 feet.

Dual Media Filter Drain for Highway Medians

The dual media filter drain is fundamentally the same as the side-slope version. It differs in siting and is more constrained with regard to drainage options. Prime locations for dual media filter drains in a highway setting are medians, roadside drainage or borrow ditches, or other linear depressions. It is especially critical for water to sheet flow across the dual media filter drain. Channelized flows or ditch flows running down the middle of the dual media filter drain (continuous off-site inflow) should be minimized.

Limitations

Media Filter Drains

- **Steep slopes.** Avoid construction on longitudinal slopes steeper than 5%. Avoid construction on 3H:1V lateral slopes, and preferably use less than 4H:1V slopes. In areas where lateral slopes exceed 4H:1V, it may be possible to construct terraces to create 4H:1V slopes or to otherwise stabilize up to 3H:1V slopes. (For details, see *Geometry, Components and Sizing Criteria, Cross Section* in the Structural Design Considerations section below).
- **Wetlands.** Do not construct in wetlands and wetland buffers. In many cases, a media filter drain (due to its small lateral footprint) can fit within the highway fill slopes adjacent to a wetland buffer. In those situations where the highway fill prism is located adjacent to wetlands, an interception trench/underdrain will need to be incorporated as a design element in the media filter drain.
- **Shallow groundwater.** Mean high water table levels at the project site need to be determined to ensure the media filter drain mix bed and the underdrain (if needed) will not become saturated by shallow groundwater.
- **Unstable slopes.** In areas where slope stability may be problematic, consult a geotechnical engineer.

Dual Media Filter Drains for Highway Medians

In addition to the above limitations on the media filter drain:

- **Wetlands.** Do not construct in wetlands and wetland buffers.
- **Areas of seasonal groundwater inundations or basement flooding.** The hydraulic and runoff treatment performance of the dual media filter drain may be compromised due to backwater effects and lack of sufficient hydraulic gradient.

Design Flow Elements

Flows to Be Treated

The basic design concept behind the media filter drain and dual media filter drain is to fully filter all runoff through the media filter drain mix. Therefore, the infiltration capacity of the medium and drainage below needs to match or exceed the hydraulic loading rate.

Structural Design Considerations

Geometry

Components

No-Vegetation Zone

The no-vegetation zone (vegetation-free zone) is a shallow gravel trench located directly adjacent to the highway pavement. The no-vegetation zone is a crucial element in a properly functioning media filter drain or other BMPs that use sheet flow to convey runoff from the highway surface to the BMP. The no-vegetation zone functions as a level spreader to promote sheet flow and a deposition area for coarse sediments. The no-vegetation zone should be between 1 foot and 3 feet wide. Depth will be a function of how the roadway section is built from subgrade to finish grade; the resultant cross section will typically be triangular to trapezoidal. Within these bounds, width varies depending on WSDOT maintenance spraying practices. Contact the area maintenance office for this information.

Grass Strip

The width of the grass strip is dependent on the availability of space within the highway side slope. The baseline design criterion for the grass strip within the media filter drain is a 3-foot-minimum-width, but wider grass strips are recommended if the additional space is available. The designer should consult with the Region Landscape Architect for soil mix recommendations. The designer may consider adding aggregate to the soil mix to help minimize rutting problems from errant vehicles. The soil mix should ensure grass growth for the design life of the media filter drain.

Media Filter Drain Mix Bed

The media filter drain mix is a mixture of crushed rock (screened to 3/8" to #10 sieve), dolomite, gypsum, and perlite. The crushed rock provides the support matrix of the medium; the dolomite and gypsum add alkalinity and ion exchange capacity to promote the precipitation and exchange of heavy metals; and the perlite improves moisture retention to promote the formation of biomass within the media filter drain mix. The combination of physical filtering, precipitation, ion exchange, and biofiltration enhances the water treatment capacity of the mix. The media filter drain mix has an estimated initial filtration rate of 50 inches per hour and a long-term filtration rate of 28 inches per hour due to siltation. With an additional safety factor, the rate used to size the length of the media filter drain should be 10 inches per hour.

Conveyance System Below Media Filter Drain Mix

The gravel underdrain trench provides hydraulic conveyance when treated runoff needs to be conveyed to a desired location such as a downstream flow control facility or stormwater outfall.

In Group C and D soils, an underdrain pipe would help to ensure free flow of the treated runoff through the media filter drain mix bed. In some Group A and B soils, an underdrain pipe may be unnecessary if most water percolates into subsoil from the underdrain trench. The need for underdrain pipe should be evaluated in all cases. The underdrain trench should be a minimum of 2 feet wide for either the conventional or dual media filter drain.

The gravel underdrain trench may be eliminated if there is evidence to support that flows can be conveyed laterally to an adjacent ditch or onto a fill slope that is properly vegetated to protect against erosion. The media filter drain mix should be kept free draining up to the 50-year storm event water surface elevation represented in the downstream ditch.

Sizing Criteria

Width

The width of the media filter drain mix bed is determined by the amount of contributing pavement routed to the embankment. The surface area of the media filter drain mix bed needs to be sufficiently large to fully infiltrate the runoff treatment design flow rate using the long-term filtration rate of the media filter drain mix. For design purposes, a 50% safety factor is incorporated into the long-term media filter drain mix filtration rate to accommodate variations in slope, resulting in a design filtration rate of 10 inches per hour. The media filter drain mix bed should have a bottom width of at least 2 feet in contact with the conveyance system below the media filter drain mix.

Length

In general, the length of a media filter drain or dual media filter drain is the same as the contributing pavement. Any length is acceptable as long as the surface area media filter drain mix bed is sufficient to fully infiltrate the runoff treatment design flow rate.

Cross Section

In profile, the surface of the media filter drain should preferably have a lateral slope less than 4H:1V (<25%). On steeper terrain, it may be possible to construct terraces to create a 4H:1V slope, or other engineering may be employed if approved by Ecology, to ensure slope stability up to 3H:1V. If sloughing is a concern on steeper slopes, consideration should be given to incorporating permeable soil reinforcements, such as geotextiles, open-graded/permeable pavements, or commercially available ring and grid reinforcement structures, as top layer components to the media filter drain mix bed. Consultation with a geotechnical engineer is required.

Inflow

Runoff is conveyed to a media filter drain using sheet flow from the pavement area. The longitudinal pavement slope contributing flow to a media filter drain should be less than 5%. Although there is no lateral pavement slope restriction for flows going to a media filter drain, the designer should ensure flows remain as sheet flow.

Media Filter Drain Mix Bed Sizing Procedure

The media filter drain mix should be a minimum of 12 inches deep, including the section on top of the underdrain trench.

For runoff treatment, sizing the media filter drain mix bed is based on the requirement that the runoff treatment flow rate from the pavement area, $Q_{Highway}$, cannot exceed the long-term infiltration capacity of the media filter drain, $Q_{Infiltration}$:

$$Q_{Highway} \leq Q_{Infiltration}$$

For western Washington, $Q_{Highway}$ is the flow rate at or below which 91% of the runoff volume for the developed TDA will be treated, based on a 15-minute time step (see Section 4-3.1.1), and can be determined using the water quality data feature in MGSFlood. For eastern Washington, $Q_{Highway}$ is the peak flow rate predicted for the 6-month, short-duration storm under post-developed conditions for each TDA (see Appendix 4C), and can be determined by selecting the short-duration storm option in StormSHED.

The long-term infiltration capacity of the media filter drain is based on the following equation:

$$\frac{LTIR * L * W}{C * SF} = Q_{Infiltration}$$

- where: $LTIR$ = Long-term infiltration rate of the media filter drain mix (use 10 inches per hour for design) (in/hr)
 L = Length of media filter drain (parallel to roadway) (ft)
 W = Width of the media filter drain mix bed (ft)
 C = Conversion factor of 43200 ((in/hr)/(ft/sec))
 SF = Safety Factor (equal to 1.0, unless unusually heavy sediment loading is expected)

Assuming that the length of the media filter drain is the same as the length of the contributing pavement, solve for the width of the media filter drain:

$$W \geq \frac{Q_{Highway} * C * SF}{LTIR * L} \quad \text{(RT.07-1)}$$

Western Washington project applications of this design procedure have shown that, in almost every case, the calculated width of the media filter drain does not exceed 1.0 foot. Therefore, Table RT.07.1 was developed to simplify the design steps and should be used to establish an appropriate width.

Table RT.07.1. Western Washington design widths for media filter drains.

Pavement width that contributes runoff to the <u>media filter drain</u>	Minimum <u>media filter drain</u> width*
≤ 20 feet	2 feet
≥ 20 and ≤ 35 feet	3 feet
> 35 feet	4 feet

* Width does not include the required 1–3 foot gravel vegetation-free zone or the 3-foot filter strip width (see Figure RT.07.1).

Materials

Media Filter Drain Mix

The media filter drain mix used in the construction of media filter drains consists of the amendments listed in Table RT.07.2. Mixing and transportation must occur in a manner that ensures the materials are thoroughly mixed prior to placement and that separation does not occur during transportation or construction operations.

These materials should be used in accordance with the following *Standard Specifications*:

- Gravel Backfill for Drains, 9-03.12(4)
- Underdrain Pipe, 7-01.3(2)
- Construction Geotextile for Underground Drainage, 9-33.1

Crushed Surfacing Base Course (CSBC)

If the design is configured to allow the media filter drain to drain laterally into a ditch (see Figure RT.07.3), the crushed surfacing base course below the media filter drain should conform to Section 9-03.9(3) of the *Standard Specifications*.

Berms, Baffles, and Slopes

See *Geometry, Components and Sizing Criteria, Cross Section* under Structural Design Considerations above.

Table RT.07.2. Media filter drain mix.

Amendment	Quantity																
<p>Mineral aggregate: Crushed screenings 3/8-inch to #10 sieve</p> <p>Crushed screenings shall be manufactured from ledge rock, talus, or gravel in accordance with Section 3-01 of the <i>Standard Specifications for Road, Bridge, and Municipal Construction</i> (2002), which meets the following test requirements:</p> <p style="margin-left: 40px;">Los Angeles Wear, 500 Revolutions 35% max. Degradation Factor 30 min.</p> <p>Crushed screenings shall conform to the following requirements for grading and quality:</p> <table border="0" style="margin-left: 40px;"> <thead> <tr> <th style="text-align: left;">Sieve Size</th> <th style="text-align: left;">Percent Passing (by weight)</th> </tr> </thead> <tbody> <tr> <td>1/2" square</td> <td>100</td> </tr> <tr> <td>3/8" square</td> <td>90-100</td> </tr> <tr> <td>U.S. No. 4</td> <td>30-56</td> </tr> <tr> <td>U.S. No. 10</td> <td>0-10</td> </tr> <tr> <td>U.S. No. 200</td> <td>0-1.5</td> </tr> <tr> <td>% fracture, by weight, min.</td> <td>75</td> </tr> <tr> <td>Static stripping test</td> <td>Pass</td> </tr> </tbody> </table> <p>The fracture requirement shall be at least one fractured face and will apply to material retained on the U.S. No. 10 if that sieve retains more than 5% of the total sample.</p> <p>The finished product shall be clean, uniform in quality, and free from wood, bark, roots, and other deleterious materials.</p> <p>Crushed screenings shall be substantially free from adherent coatings. The presence of a thin, firmly adhering film of weathered rock shall not be considered as coating unless it exists on more than 50% of the surface area of any size between successive laboratory sieves.</p>	Sieve Size	Percent Passing (by weight)	1/2" square	100	3/8" square	90-100	U.S. No. 4	30-56	U.S. No. 10	0-10	U.S. No. 200	0-1.5	% fracture, by weight, min.	75	Static stripping test	Pass	3 cubic yards
Sieve Size	Percent Passing (by weight)																
1/2" square	100																
3/8" square	90-100																
U.S. No. 4	30-56																
U.S. No. 10	0-10																
U.S. No. 200	0-1.5																
% fracture, by weight, min.	75																
Static stripping test	Pass																
<p>Perlite:</p> <ul style="list-style-type: none"> ▪ Horticultural grade, free of any toxic materials) ▪ 0-30% passing US No. 18 Sieve ▪ 0-10% passing US No. 30 Sieve 	1 cubic yard per 3 cubic yards of mineral aggregate																
<p>Dolomite: CaMg(CO₃)₂ (calcium magnesium carbonate)</p> <ul style="list-style-type: none"> ▪ Agricultural grade, free of any toxic materials) ▪ 100% passing US No. 8 Sieve ▪ 0% passing US No. 16 Sieve 	10 pounds per cubic yard of perlite																
<p>Gypsum: Noncalcined, agricultural gypsum CaSO₄•2H₂O (hydrated calcium sulfate)</p> <ul style="list-style-type: none"> ▪ Agricultural grade, free of any toxic materials) ▪ 100% passing US No. 8 Sieve ▪ 0% passing US No. 16 Sieve 	1.5 pounds per cubic yard of perlite																

Site Design Elements

Landscaping (Planting Considerations)

Landscaping is the same as for biofiltration swales (see BMP RT.04) unless otherwise specified in the special provisions for the project's construction documents.

Operations and Maintenance

Maintenance will consist of routine roadside management. While herbicides will not be applied directly over the media filter drain, it may be necessary to periodically control noxious weeds with herbicides in areas around the media filter drain as part of WSDOT's roadside management program. The use of pesticides may be prohibited if the media filter drain is in a critical aquifer recharge area for drinking water supplies. The designer should check with the local area water purveyor or local health department. Areas of the media filter drain that show signs of physical damage will be replaced by local maintenance staff in consultation with region hydraulics/water quality staff.

Signing

Nonreflective guideposts will delineate the media filter drain. This practice allows WSDOT personnel to identify where the system is installed and to make appropriate repairs should damage occur to the system. If the media filter drain is in a critical aquifer recharge area for drinking water supplies, signage prohibiting the use of pesticides must be provided.

5-4.1.4 Wet Pool BMPs

RT.12 – Wet Pond



Dual-Celled Wet Pond Along I-5 in Clark County.

Introduction

General Description

A *wet pond* is a constructed stormwater pond that retains a permanent pool of water (wet pool), at least during the wet season. The volume of the wet pool is related to the effectiveness of the pond in settling particulate pollutants. As an option, a shallow marsh area can be created within the permanent pool volume to provide additional treatment for nutrient removal. Peak flow control can be provided in the live storage area above the permanent pool. Figures RT.12.1 and RT.12.2 illustrate a typical wet pond BMP.

Applications and Limitations

A wet pond BMP must be an on-line facility receiving runoff from only new impervious areas or equivalent areas. If a decision has been made to treat runoff from existing impervious surfaces per the retrofit instructions in Section 3-4, then the wet pond BMP would be an on-line facility receiving runoff from the new plus existing impervious areas or equivalent areas.

Wet ponds can be designed in two sizes: basic and large (see Table 3-1). Basic wet ponds are approved basic runoff treatment BMPs. Large wet ponds are designed for higher levels of pollutant removal and are an appropriate treatment BMP for phosphorus control. It is recommended that all runoff treatment BMPs that use permanent wet pools use facility liners. Additional information can be found in Section 5-4.3.3.

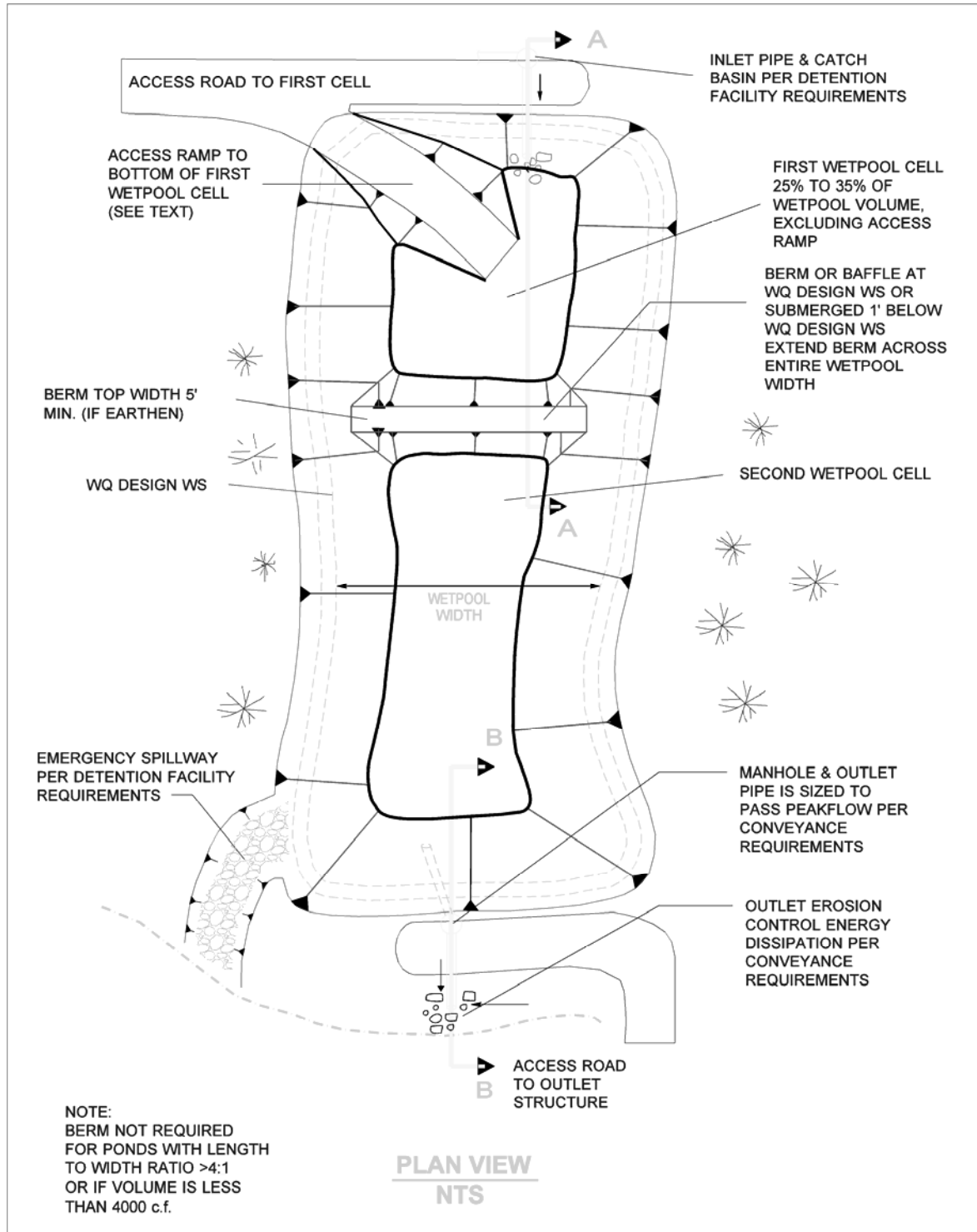

Figure RT.12.1. Wet pond: Plan view.

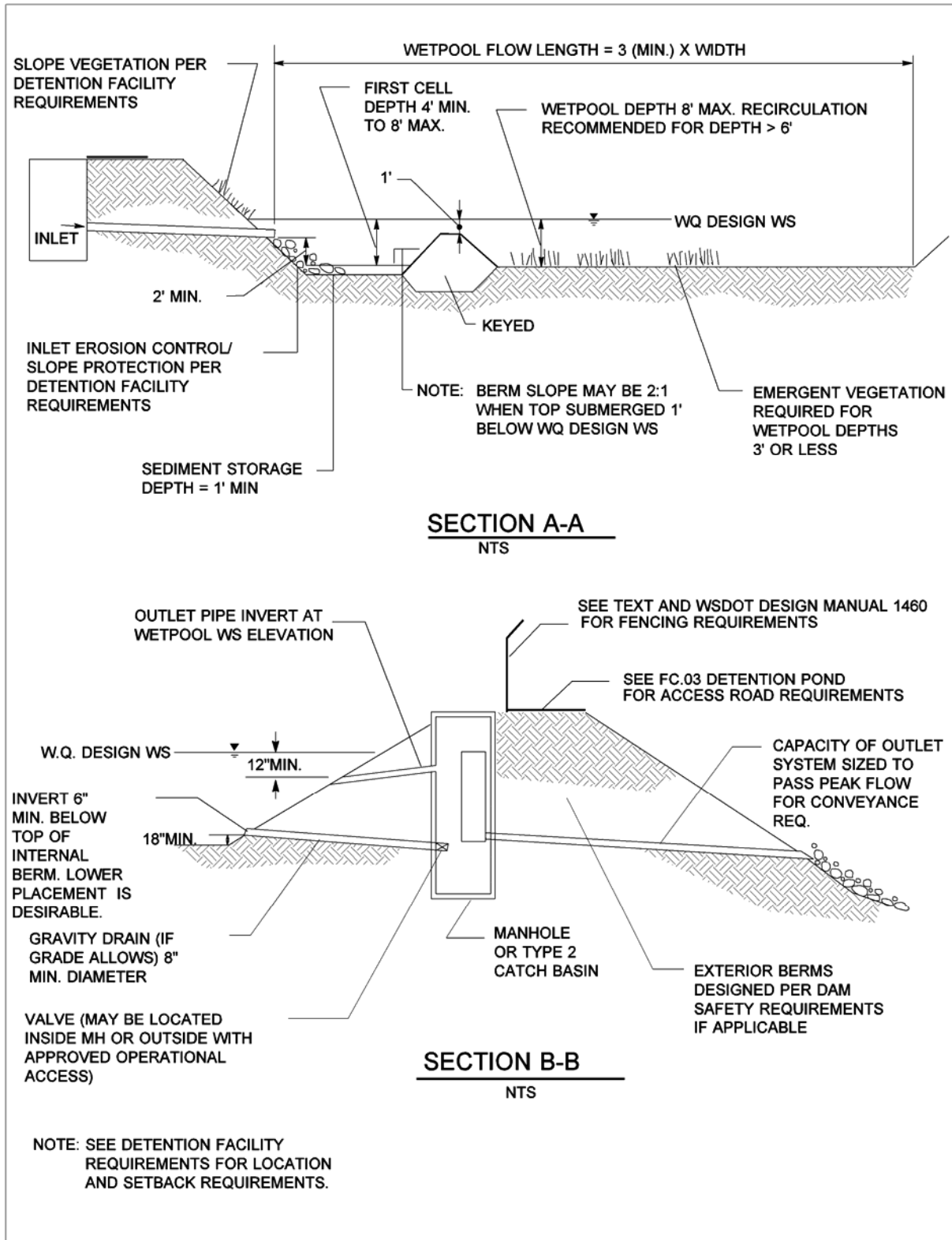

Figure RT.12.2. Wet pond: Cross section.

Refer to BMP CO.01 (Combined Wet/Detention Pond) if the pond is to be used for flow control in addition to runoff treatment.

Design Flow Elements

Flows to Be Treated

Basic wet ponds are designed to treat the runoff treatment volume described in Section 3-3.5 under Minimum Requirement 5. Large wet ponds are designed to treat a volume 1.5 times greater than the runoff treatment volume. Hydrologic methods are presented in Sections 4-3 and 4-4.

Overflow or Bypass

The overflow criteria for single-purpose (treatment only, not combined with flow control) wet ponds are as follows:

- An open top standpipe riser in the control structure satisfies the requirement for primary overflow design (see Figure RT.12.2)
- The top of the riser should be set at the water quality design water surface elevation
- The primary overflow should be sized to pass the 100-year flow

Emergency Overflow Spillway

An emergency spillway or structure must be provided and designed according to the requirements for detention ponds (see BMP FC.03). The bottom of the emergency overflow spillway must be set at the design water surface elevation (see Figure FC.03.3).

Structural Design Considerations

Geometry

Design Criteria

- The wet pond is divided into a minimum of two cells separated by a baffle or berm. The first cell must contain between 25% and 35% of the total wet pond volume. The baffle or berm volume does not count as part of the total wet pond volume. The term baffle means a vertical divider placed across the entire width of the pond, stopping short of the bottom. A berm is a vertical divider typically built up from the bottom; in a wet vault, it connects all the way to the bottom.

Intent: The full-length berm or baffle promotes plug flow and enhances quiescence and laminar flow through as much of the entire water volume as possible. Alternative methods to the full-length berm or baffle that provide equivalent flow characteristics may be approved on a case-by-case basis by the local jurisdiction.

- Sediment storage is provided in the first cell. The minimum depth of the sediment storage must be 1 foot. A fixed sediment depth monitor should be installed in the first cell to gauge sediment accumulation or an alternative gauging method should be used.
- The minimum depth of the first cell must be 4 feet, exclusive of sediment storage requirements. The depth of the first cell may be greater than the depth of the second cell.
- The maximum depth of each cell must not exceed 8 feet (exclusive of sediment storage in the first cell). Pool depths of 3 feet or shallower (second cell) must be planted with emergent wetland vegetation (see *Landscaping* requirements later in this section).
- Inlets and outlets must be placed to maximize the flow path through the facility. The ratio of flow path length to width from the inlet to the outlet must be at least 3:1. The *flow path length* is defined as the distance from the inlet to the outlet, as measured at mid-depth. The *width* at mid-depth is calculated as follows: width = (average top width + average bottom width)/2.
- Wet ponds with wet pool volumes less than or equal to 4000 cubic feet may be single-celled (no baffle or berm is required). However, it is especially important that the flow path length be maximized in single-celled wet ponds. The ratio of flow path length to width must be greater than 4:1 in single-celled wet ponds.
- All inlets must enter the first cell. If there are multiple inlets, the length-to-width ratio is based on the average flow path length for all inlets.
- The first cell may be lined in accordance with the liner recommendations contained in Section 5-4.3.3.

Sizing Procedure

Design Steps (D)

D-1 Identify the required wet pool volume (Vol_{wq}). For options to determine this volume using continuous runoff models, see Chapter 4. For large wet ponds, the wet pool volume is 1.5 times the water quality volume.

D-2 Estimate wet pool dimensions satisfying the following design criterion:

$$Vol_{wq} = [h_1(A_{t1} + A_{b1}) / 2] + [h_2(A_{t2} + A_{b2}) / 2] + \dots + [h_n(A_m + A_{bn}) / 2]$$

where: A_m = top area of wet pool surface in cell n (ft²)

A_{bn} = bottom area of wet pool surface in cell n (ft²)

h_n = depth of wet pool in cell n (above top of sediment storage) (ft)

- D-3** Design pond outlet pipe and determine primary overflow water surface. (See the *Hydraulics Manual* for design of pond outlet pipe and method to determine primary overflow water surface.)

Inlet and Outlet

For details on the following requirements, see Figures RT.12.1 and RT.12.2.

- The inlet to the wet pond must be submerged, with the inlet pipe invert a minimum of 2 feet from the pond bottom (not including the 1-foot-minimum sediment storage). The top of the inlet pipe should be submerged at least 1 foot below the runoff treatment design water surface if possible. The designer shall compute the hydraulic grade line (HGL) of the inlet pipe to verify that backwater conditions are acceptable. (See the *Hydraulics Manual* for computing an HGL.)

Intent: The inlet is submerged to dissipate the energy of the incoming flow. The distance from the bottom is set to minimize resuspension of settled sediments. Alternative inlet designs that accomplish these objectives are acceptable.

- An outlet structure must be provided. Either a Type 2 catch basin (see the *WSDOT Standard Plans for Road, Bridge, and Municipal Construction [Standard Plans]*) or a manhole with a cone grate (birdcage) may be used. No sump is required in the outlet structure for wet ponds not providing detention storage. The outlet structure receives flow from the pond outlet pipe. The birdcage opening provides an overflow route should the pond outlet pipe become clogged.
- The pond outlet pipe (from the pond into the outlet structure) must be back-sloped, or have a turn-down elbow, and extend 1 foot below the runoff treatment design water surface. A floating outlet, set to draw water from 1 foot below the water surface, is also acceptable if vandalism concerns are adequately addressed.

Intent: The inverted outlet pipe traps oils and floatables in the wet pond.

- The pond outlet pipe must be sized, at a minimum, to pass the runoff treatment design flow. Note: The highest invert of the outlet pipe sets the runoff treatment design water surface elevation.

Materials

- All metal parts must be corrosion-resistant. Galvanized materials should not be used unless unavoidable.

Intent: Galvanized metal contributes zinc to stormwater, sometimes in very high concentrations.

Berms, Baffles, and Slopes

- A berm or baffle must extend across the full width of the wet pool and tie into the wet pond side slopes. If the berm embankments are greater than 4 feet high, the berm must be constructed by excavating a key trench equal to 50% of the embankment cross-sectional height and width. A geotechnical engineer may waive this requirement for specific site conditions. A geotechnical analysis must address situations in which one of the two cells is empty while the other remains full of water.
- The top of the berm may be at the runoff treatment design water surface or submerged 1 foot below this surface. If the top of the berm is at the runoff treatment design water surface, berm side slopes should be 3H:1V. Berm side slopes may be steeper (up to 2H:1V) if the berm is submerged 1 foot. Earthen berms should have a minimum top width of 5 feet.

Intent: Submerging the berm is intended to enhance safety by discouraging pedestrian access when side slopes are steeper than 3H:1V. An alternative to the submerged berm design is the use of barrier planting to prevent easy access to the divider berm in an unfenced wet pond.

- If good vegetation cover is not established on the berm, erosion control measures should be used to prevent erosion of the berm backslope when the pond is initially filled.
- The interior berm or baffle may be a retaining wall, provided that the design is prepared and stamped by a licensed civil engineer. If a baffle or retaining wall is used, it should be submerged 1 foot below the design water surface to discourage access by pedestrians.
- Criteria for wet pond side slopes are as follows:
 - Interior side slopes must be no steeper than 3H:1V. Steeper side slopes reduce the pond area where emergent vegetation can grow. Flatter side slopes promote dense emergent vegetation, which also can create problems: (1) it provides predator-free shoreline habitats for mosquito production, and (2) it reduces or eliminates access to the pond for routine inspections and maintenance.
 - Exterior side slopes must be no steeper than 2H:1V.
 - Slopes should be no steeper than 4H:1V if they are to be mowed.
 - Pond sides may be retaining walls, provided that a fence is situated along the top of the wall and at least 25% of the pond perimeter is a vegetated side slope no steeper than 3H:1V.
 - The toe of the exterior slope must be no closer than 5 feet from the right of way line.

Embankments

- Embankments that impound water must comply with the Washington dam safety regulations (WAC 173-175). If the impoundment has a storage capacity (including both water and sediment storage volumes) greater than 10 acre-feet (435,600 cubic feet, or 3.26 million gallons) above natural ground level, then dam safety design and review are required by Ecology. (See discussion in BMP FC.03, Detention Pond.)
- The berm embankment must be constructed in accordance with Section 2-03.3(14)C, Method C, of the *Standard Specifications*.
- The berm embankment must be constructed of material consisting of a minimum of 30% clay, a maximum of 60% sand, a maximum of 60% silt, and negligible gravel and cobble.
- To prevent undermining, installation of a perimeter cutoff trench underneath or near embankments should be considered.
- Antiseepage collars must be placed on outflow pipes in berm embankments impounding water deeper than 8 feet at the runoff treatment design water surface. Antiseepage collars may also be necessary in other situations.

Site Design Elements

Setback Requirements

- Wet ponds must be a minimum of 5 feet from any property line or vegetative buffer. This distance may need to be increased based on the permit requirements of the local jurisdiction.
- Wet ponds must be 100 feet from any septic tank or drain field (except wet vaults must be a minimum of 20 feet).
- The designer should request from the WSDOT Materials Lab a geotechnical report for the project that evaluates any potential structural site instability due to extended subgrade saturation or head loading of the permeable layer. This includes the potential impacts to downgradient properties, especially on hills with known side-hill seeps. The report should address the adequacy of the proposed wet pond locations and recommend the necessary setbacks from any steep slopes and building foundations.

Landscaping (Planting Considerations)

Planting requirements for detention ponds (see BMP FC.03) also apply to wet ponds.

- The cells in large wet ponds intended for phosphorus control should not be planted because the plants release phosphorus in the winter when they die off.
- If the second cell of a basic wet pond is 3 feet or shallower, the bottom area must be planted with emergent wetland vegetation. This results in habitat for

natural predators of mosquitoes such as dragonflies, birds, fish, and frogs. (See Table RT.12.1 for recommended emergent wetland plant species for wet ponds.)

Intent: Planting of shallow pond areas helps to stabilize settled sediment and prevent resuspension.

- Cattails (*Typha latifolia*) are not recommended because they tend to crowd out other species in the wet pond and typically escape to other wetland areas where they do the same. They also create dense emergent vegetation that can provide a safe haven for mosquito larvae.
- Vegetation that forms floating mats should not be planted because the mats protect mosquito larvae.
- A variety of plant species should be planted to encourage a diversity of mosquito predators. This variety can also make the overall predator population more robust to withstand environmental changes to the facility.
- If the wet pond discharges to a phosphorus-sensitive lake or wetland, shrubs that form a dense cover should be planted on slopes above the runoff treatment design water surface on at least three sides. For banks that are berms, no planting is allowed if the berm is regulated by dam safety requirements. The purpose of planting is to discourage waterfowl use of the pond and to provide shading. Some suitable trees and shrubs include vine maple (*Acer circinatum*), wild cherry (*Prunus emarginata*), red osier dogwood (*Cornus stolonifera*), California myrtle (*Myrica californica*), Indian plum (*Oemleria cerasiformis*), and Pacific yew (*Taxus brevifolia*).

Fencing

Pond walls may be retaining walls as long as a fence is provided along the top of the wall and at least 25% of the pond perimeter will have a slope of 3H:1V or flatter. (See the *Design Manual* for additional fencing requirements.)

General Maintenance Requirements

- For general maintenance requirements for wet ponds, see Section 5-3.6.1.

Table RT.12.1. Emergent wetland plant species recommended for wet ponds.

Species	Common Name	Notes	Maximum Depth
Inundation to 1 Foot			
<i>Agrostis exarata</i> ⁽¹⁾	Spike bent grass	Prairie to coast	to 2 feet
<i>Carex stipata</i>	Sawbeak sedge	Wet ground	
<i>Eleocharis palustris</i>	Spike rush	Margins of ponds, wet meadows	to 2 feet
<i>Glyceria occidentalis</i>	Western mannagrass	Marshes, pond margins	to 2 feet
<i>Juncus tenuis</i>	Slender rush	Wet soils, wetland margins	
<i>Oenanthe sarmentosa</i>	Water parsley	Shallow water along stream and pond margins; needs saturated soils all summer	
<i>Scirpus atrocinctus</i> (formerly <i>S. cyperinus</i>)	Woolgrass	Tolerates shallow water; tall clumps	
<i>Scirpus microcarpus</i>	Small-fruited bulrush	Wet ground to 18 inches depth	18 inches
<i>Sagittaria latifolia</i>	Arrowhead		
Inundation 1 to 2 Feet			
<i>Agrostis exarata</i> ⁽¹⁾	Spike bent grass	Prairie to coast	
<i>Alisma plantago-aquatica</i>	Water plantain		
<i>Eleocharis palustris</i>	Spike rush	Margins of ponds, wet meadows	
<i>Glyceria occidentalis</i>	Western mannagrass	Marshes, pond margins	
<i>Juncus effusus</i>	Soft rush	Wet meadows, pastures, wetland margins	
<i>Scirpus microcarpus</i>	Small-fruited bulrush	Wet ground to 18 inches depth	18 inches
<i>Sparganium emersum</i>	Bur-reed	Shallow standing water, saturated soils	
Inundation 1 to 3 Feet			
<i>Carex obnupta</i>	Slough sedge	Wet ground or standing water	1.5 to 3 feet
<i>Beckmania syzigachne</i> ⁽¹⁾	Western sloughgrass	Wet prairie to pond margins	
<i>Scirpus acutus</i> ⁽²⁾	Hardstem bulrush	Single tall stems, not clumping	to 3 feet
<i>Scirpus validus</i> ⁽²⁾	Softstem bulrush		
Inundation Greater Than 3 Feet			
<i>Nuphar polysepalum</i>	Spatterdock	Deep water	3 to 7.5 feet
<i>Nymphaea odorata</i> ⁽¹⁾	White waterlily	Shallow to deep ponds	to 6 feet

Primary sources: Metro 1990; Hortus Northwest 1991; Hitchcock and Cronquist 1973.

⁽¹⁾ Non-native species. *Beckmania syzigachne* is native to Oregon. Native species are preferred.

⁽²⁾ *Scirpus* tubers must be planted shallower for establishment and protected from foraging waterfowl until established. Emerging aerial stems should project above water surface to allow oxygen transport to the roots.

Note: The recommendations in Table RT.12.1 are for western Washington only. Consult with a landscape architect to adapt this information for eastern Washington.

Recommended Design Features

The following design features should be incorporated into the wet pond design where site conditions allow:

- For wet pool depths in excess of 6 feet, it is recommended that some form of recirculation be provided in the summer. A fountain or aerator may be used to prevent stagnation and low-dissolved-oxygen conditions. Alternatively, a small amount of base flow could be directed to the pond to maintain circulation and reduce the potential for low oxygen conditions during late summer.
- Conifer or columnar deciduous trees along the west and south sides of ponds are recommended to reduce thermal heating, except that no trees or shrubs may be planted on berms meeting the criteria of dams regulated for safety. In addition to shade, trees and shrubs also discourage waterfowl use and the attendant phosphorus enrichment problems they cause. Trees should be set back so that the branches will not extend over the pond.

Intent: Conifer trees or shrubs are preferred to avoid problems associated with leaf drop. Columnar deciduous trees (such as hornbeam and Lombardy poplar) typically have fewer leaves than other deciduous trees.

- The number of inlets to the facility should be limited; ideally, there should be only one inlet. Regardless of the number of inlets, the flow path length between inlet and outlet should be maximized.
- The access and maintenance road could be extended along the full length of the wet pond to function as a vegetated filter strip (see BMP RT.02) if finely ground bark, wood chips, or permeable surfacing is placed over the road surface to reduce runoff.

The following design features should be incorporated where possible to enhance aesthetics:

- Provide side slopes that are sufficiently gentle (3H:1V or flatter) to avoid the need for fencing. Gentler slopes typically allow a facility to better blend into its surroundings.
- Use sinuous or irregularly shaped ponds to create a more naturalistic landscape.
- Provide visual enhancement with clusters of trees and shrubs. On most pond sites, it is important to amend the soil before planting because ponds are typically placed well below the native soil horizon in very poor soils. Make sure dam safety restrictions against planting do not apply.
- Orient the pond length along the direction of prevailing summer winds (typically west or southwest) to enhance wind mixing.

Construction Criteria

- Sediment that has accumulated in the pond must be removed after construction in the drainage area of the pond is complete unless used for a liner (see below).
- Sediment accumulations in the pond at the end of construction may be used as a liner in excessively drained wet pond soils if the sediment meets the criteria for low-permeability or treatment liners (see Section 5-4.3.2). Sediment used for a soil liner must be graded to provide uniform coverage and thickness. Note: Sediment accumulated from construction and left in the pond for a liner must not reduce the volume of the wet pond below its design capacity; therefore, the pond should be overexcavated initially.

CO.01 – Combined Wet/Detention Pond



Combination Wet/Detention Pond Along SR 500 in Clark County.

Introduction

General Description

A combined detention and runoff treatment wet pond facility has the appearance of a detention facility, but contains a permanent pool of water as well. The following design procedures, requirements, and recommendations cover differences in the design of the stand-alone runoff treatment facility when combined with detention storage.

There are two sizes of the combined wet pond: basic and large. The facility sizes (basic and large) are related to the pollutant-removal goals.

Applications and Limitations

Combined detention and runoff treatment facilities are very efficient for sites that also have flow control requirements but are not conducive to dispersion or infiltration. The runoff treatment BMP may often be placed beneath detention storage without increasing the overall facility surface area. However, the fluctuating water surface of the live storage creates unique challenges for plant growth and for aesthetics.

The basis for pollutant removal in combined facilities is the same as that for stand-alone runoff treatment facilities. However, in the combined facility, the detention function creates fluctuating water levels and added turbulence. For simplicity, the positive effect of the extra live storage volume and the negative effect of increased turbulence are assumed to balance and are thus ignored when the wet pool volume is sized. For the combined detention/stormwater wetland (see BMP CO.02), criteria that limit the extent of water level fluctuation are specified to better ensure survival of the wetland plants.

Unlike the wet pool volume, the live storage component of the facility must be provided above the seasonal high water table. It is recommended that all runoff treatment BMPs that use permanent wet pools use facility liners. (See Section 5-4.3.3 for additional information.)

Typical design details and concepts for a combined detention and wet pond are shown in Figures CO.01.1 and CO.01.2. The detention portion of the facility must meet the design criteria and sizing procedures set forth in BMP FC.03, Detention Pond.

Design Flow Elements

Flows to Be Treated

Basic combined wet/detention ponds are designed to treat the runoff treatment volume and detain flows according to the criteria described in Sections 3-3.5 and 3-3.6 under Minimum Requirements 5 and 6, respectively. Large combined wet/detention ponds are designed to treat 1.5 times the runoff treatment volume. Hydrologic methods are presented in Sections 4-3 and 4-4.

Structural Design Considerations

Geometry

The geometry criteria for wet ponds (see BMP RT.12) apply, with the following modifications and clarifications:

- The permanent pool may be made shallower to take up most of the pond bottom, or it may be deeper and positioned to take up only a limited portion of the bottom. Wet pond criteria governing water depth, however, must still be met. (See Figure CO.01.3 for two possibilities for wet pool cell placement.)

Intent: This flexibility in positioning cells allows for multiple-use options in live storage areas during the drier months.

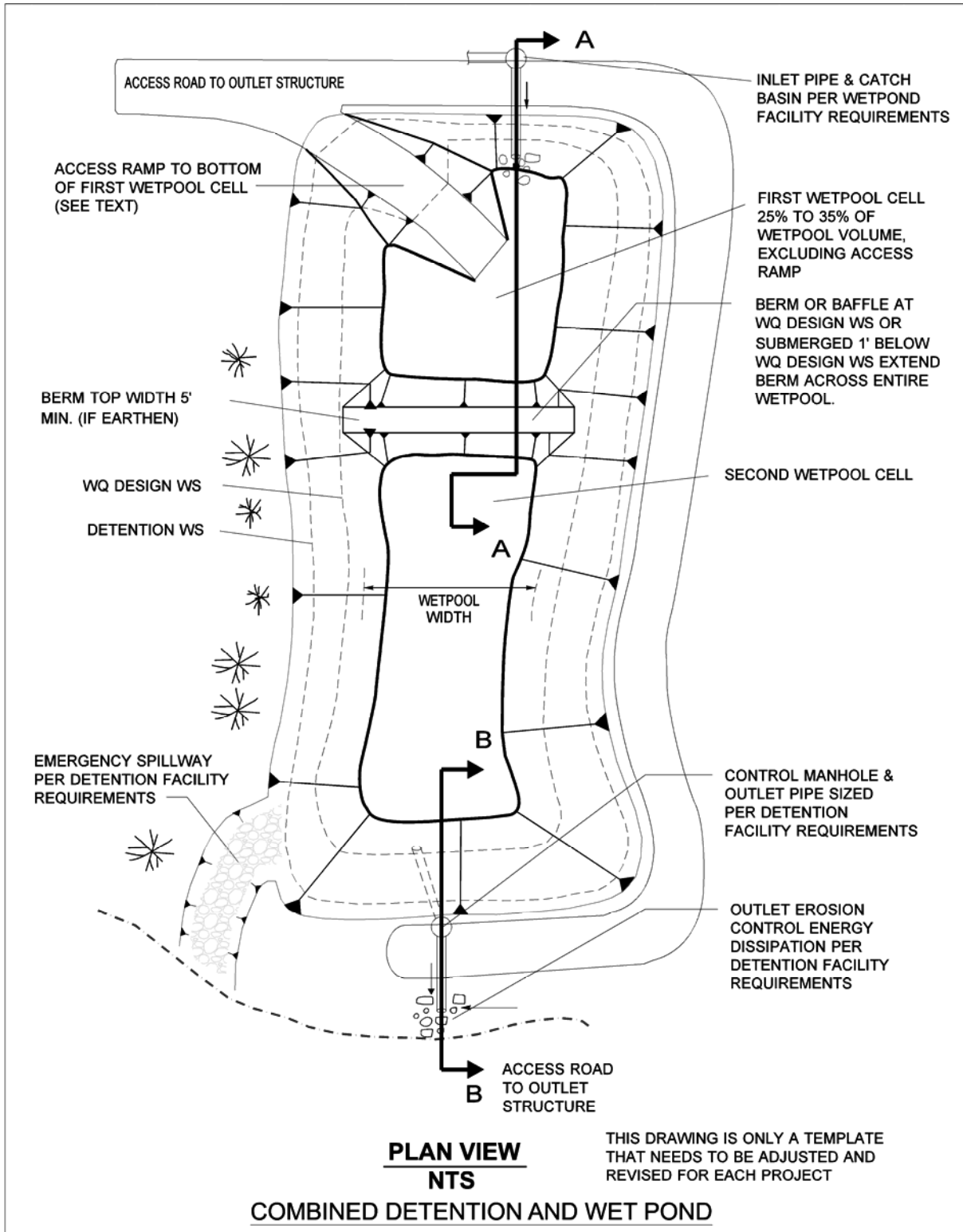

Figure CO.01.1. Combined detention and wet pond: Plan view.

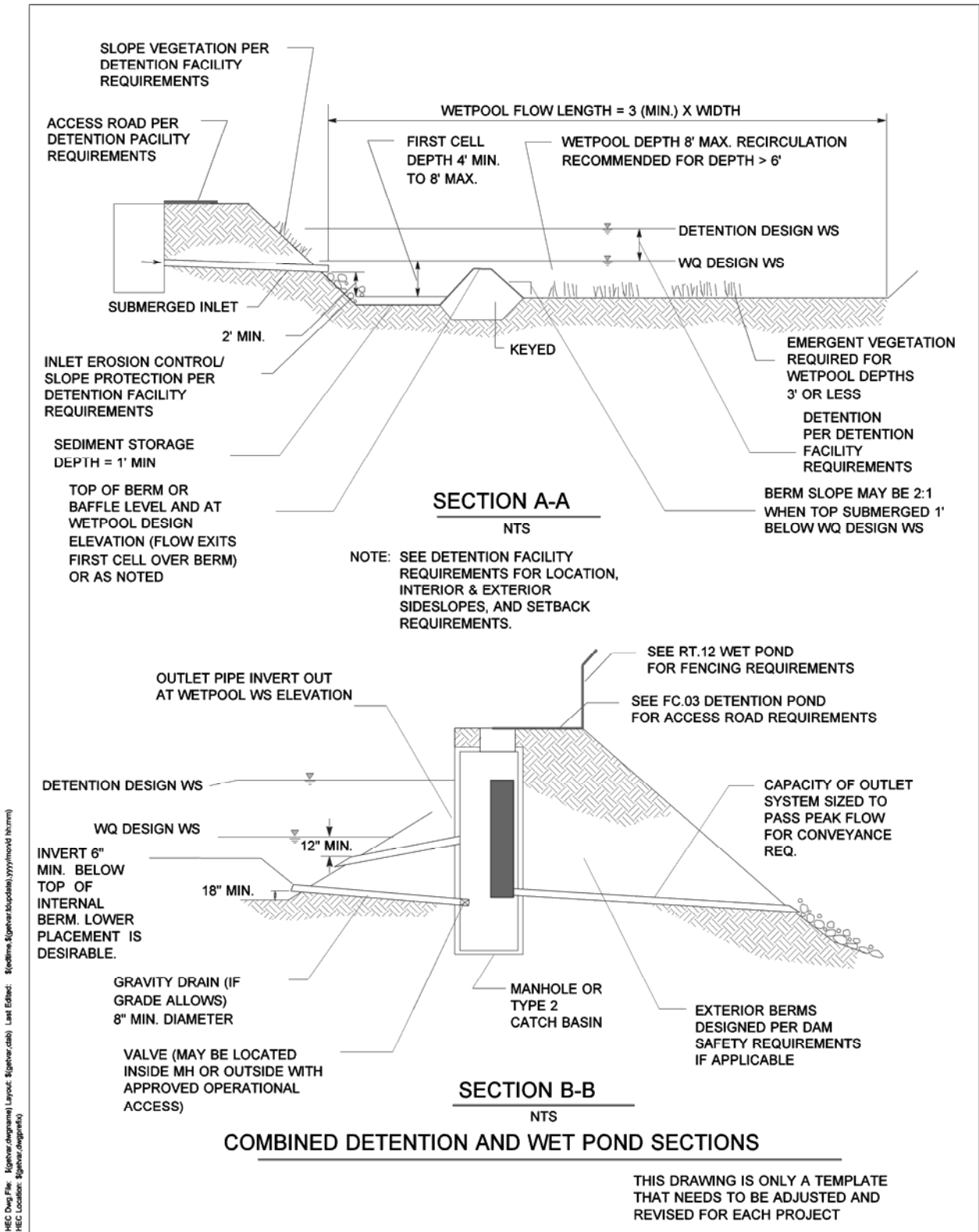

Figure CO.01.2. Combined detention and wet pond: Cross sections.

- The minimum sediment storage depth in the first cell is 1 foot. The 6 inches of sediment storage required for a detention pond does not need to be added to this, but 6 inches of sediment storage must be added to the second cell to comply with the detention sediment storage requirement.
- The wet pool and sediment storage volumes are not included in the required detention volume.

Sizing Procedure

The sizing procedure for combined detention and wet ponds is identical to that outlined for wet ponds (see BMP RT.12) and detention ponds (see BMP FC.03).

Inlet and Outlet

The inlet and outlet criteria for wet ponds (see BMP RT.12) apply, with the following modifications:

- A sump must be provided in the outlet structure of combined ponds.
- The detention flow restrictor and its outlet pipe must be designed according to the requirements for detention ponds (see BMP FC.03).

Berms, Baffles, and Slopes

Criteria are the same as for wet ponds (see BMP RT.12).

Groundwater Issues

Live storage requirements are the same as for detention ponds (see BMP FC.03). This does not apply to the wet pond dead storage component.

Site Design Elements

General Maintenance Requirements and Setbacks

Criteria are the same as for wet ponds (see BMP RT.12).

Planting Requirements

Criteria are the same as for wet ponds (see BMP RT.12).

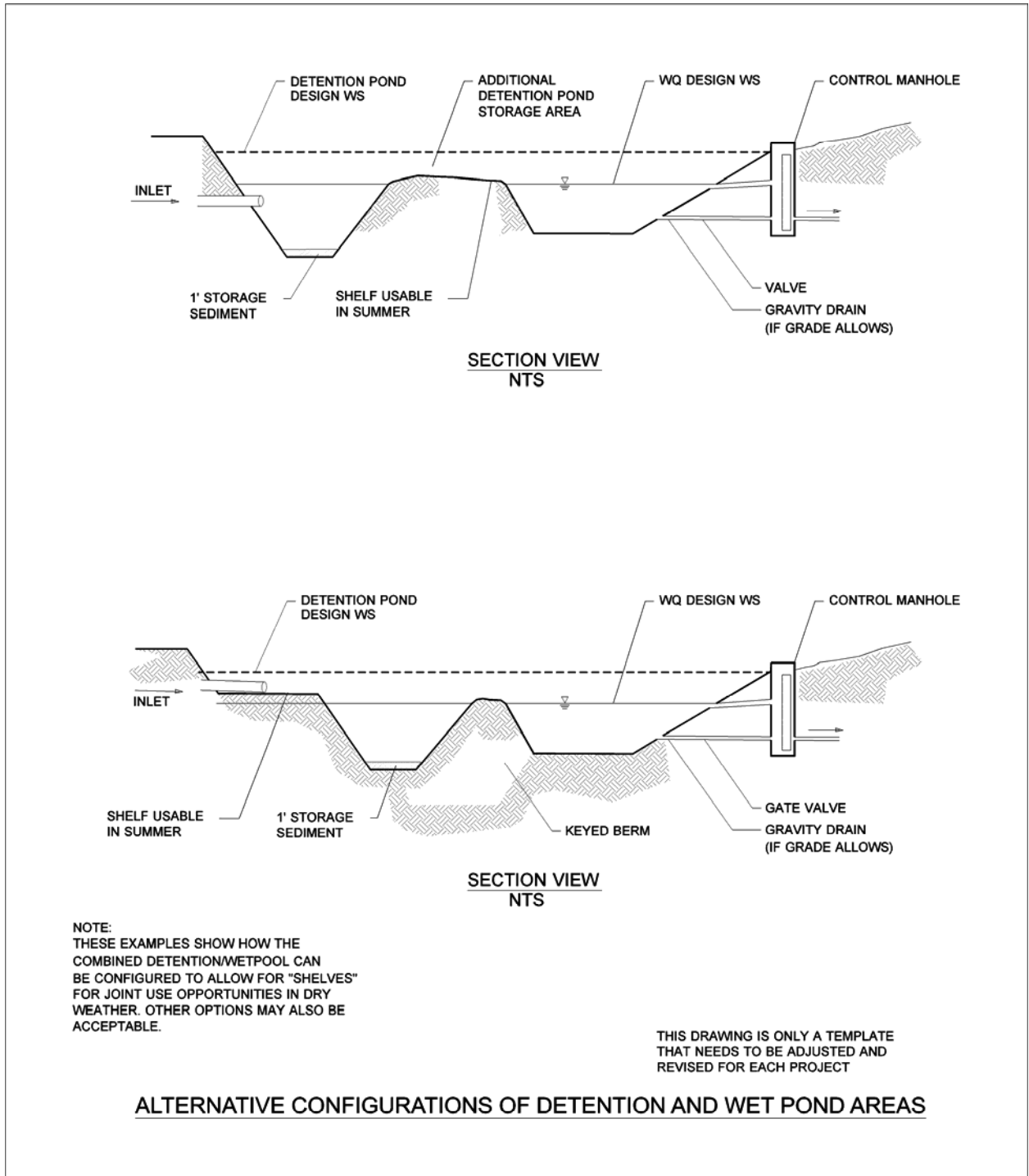

Figure CO.01.3. Alternative configurations of detention and wet pond areas.

RT.13 – Constructed Stormwater Treatment Wetland

Constructed Wetland Near the South Renton Park-and-Ride Facility.

Introduction***General Description***

Stormwater treatment wetlands are shallow constructed wetlands designed to treat stormwater through settling, filtering, and the biological processes associated with emergent aquatic plants. Stormwater treatment wetlands, like wet ponds, are used to capture and transform pollutants. Over time, these pollutants concentrate in the sediment.

Instead of treating stormwater runoff, some wetlands are constructed to replace or mitigate impacts when natural wetlands are filled or impacted by development (mitigation wetlands). Natural wetlands and mitigation wetlands cannot be used to treat stormwater.

Applications and Limitations

As an enhanced treatment BMP, stormwater wetlands can be considered for roadways where metal removal is a concern. Stormwater wetlands occupy roughly the same surface area as wet ponds, but they have the potential to be better integrated aesthetically into a site because of the abundance of emergent aquatic vegetation. The most critical factor for a successful design is an adequate supply of water for most of the year. Careful planning is needed to ensure sufficient water is retained to sustain good wetland plant growth. Because water depths in stormwater wetlands are shallower than in wet ponds, water loss by evaporation is an important concern. Stormwater wetlands are a good runoff treatment facility choice in areas where groundwater levels are high in the winter. It is recommended that all runoff treatment BMPs that use permanent wet pools use facility liners (see Section 5-4.3.3).

Design Flow Elements

Flows to Be Treated

Constructed stormwater treatment wetlands are designed to treat the runoff treatment volume (Vol_{WQ}) described in Section 3-3.5 under Minimum Requirement 5. Hydrologic methods are presented in Sections 4-3 and 4-4.

Overflow or Bypass

The overflow criteria for single-purpose wetlands (treatment only, not combined with flow control) follow the same criteria for wet ponds (see BMP RT.12).

Emergency Overflow Spillway

- An emergency spillway must be provided and designed according to the requirements for detention ponds (see BMP FC.03). In addition, a bypass or shutoff valve to enable the wetland to be taken off-line for maintenance purposes should be provided if possible.
- Bioengineered stabilization measures should be provided at the end of the outlet pipe and spillway to minimize the need for riprap and to increase aesthetics.

Structural Design Considerations

Geometry

Design Criteria

1. Stormwater wetlands must consist of two cells: presettling cell and wetland cell.
2. The presettling cell must contain approximately 33% of the wet pool volume.
3. The depth of the presettling cell must be between 4 feet (minimum) and 8 feet (maximum), excluding sediment storage.
4. The presettling cell must provide 1 foot of sediment storage.
5. The wetland cell must have an average water depth of about 1.5 feet (plus or minus 3 inches).

Sizing Procedure

Step 1 Specify the depth of the presettling cell (D_{pc} ft). (See Criterion 3 in the *Design Criteria* listed above.)

Step 2 Determine the volume of the presettling cell (V_{pc} ft³) by using criterion 2 in the *Design Criteria* listed above. $V_{pc} = V_{total} \times 0.33$. V_{total} is the total runoff treatment wetpool volume obtained in MGSFlood. Refer to Table 3-3 and Table 3-4 to determine the sizing of the runoff treatment wetpool volume (V_{total}). If V_{total} is

less than 9,410 ft³, the designer must consult region hydraulic staff due to possible constructibility issues with the presettling cell.

- Step 3** Determine the surface area of the presettling cell (A_{pc} ft²) of the stormwater wetland using the presettling cell volume and depth. $A_{pc} = V_{pc} / D_{pc}$.
- Step 4** Calculate the surface area of the stormwater wetland. The surface area of the entire wetland (A_{total} ft²) must be the same as the top area of a wet pond sized for the same site conditions. The surface area of the entire stormwater wetland is the runoff treatment wetpool volume divided by the wetpool water depth (use 3 feet). $A_{total} = V_{total} / 3$ ft.
- Step 5** Determine the surface area of the wetland cell (A_{wc} ft²). Subtract the surface area of the presettling cell from the total wetland surface area (A_{total}). $A_{wc} = A_{total} - A_{pc}$.
- Step 6** Determine water depth distribution in the wetland cell. Decide whether the top of the dividing berm is at the surface or submerged (designer's choice). Adjust distribution of water depths in the wetland cell according to the surface area of the wetland cell (A_{wc}) and the discussion below. Note: This results in a facility that holds less volume than the runoff treatment volume; this is acceptable.

Intent: The surface area of the stormwater wetland is set to be roughly equivalent to that of a wet pond (with an average depth of the wetland cell of 1.5 feet) designed for the same site so as not to discourage use of this option.

Two examples for grading the bottom of the wetland cell are shown in Figure RT.13.1. One example is a shallow, evenly graded slope from the upstream to the downstream edge of the wetland cell. The second example is a naturalistic alternative, with the specified range of depths intermixed throughout the second cell. A distribution of depths must be provided in the wetland cell depending on whether the dividing berm is at the water surface or submerged (see Table RT.13.1). The maximum depth is 2.5 feet in either configuration. Other configurations within the wetland geometry constraints listed above may be approved by the local jurisdiction.

Table RT.13.1. Distribution of depths in wetland cell.

Dividing Berm at Runoff Treatment Design Water Surface		Dividing Berm Submerged 1 Foot	
Depth Range (feet)	Percent	Depth Range (feet)	Percent
0.1 to 1	25	1 to 1.5	40
1 to 2	55	1.5 to 2	40
2 to 2.5	20	2 to 2.5	20

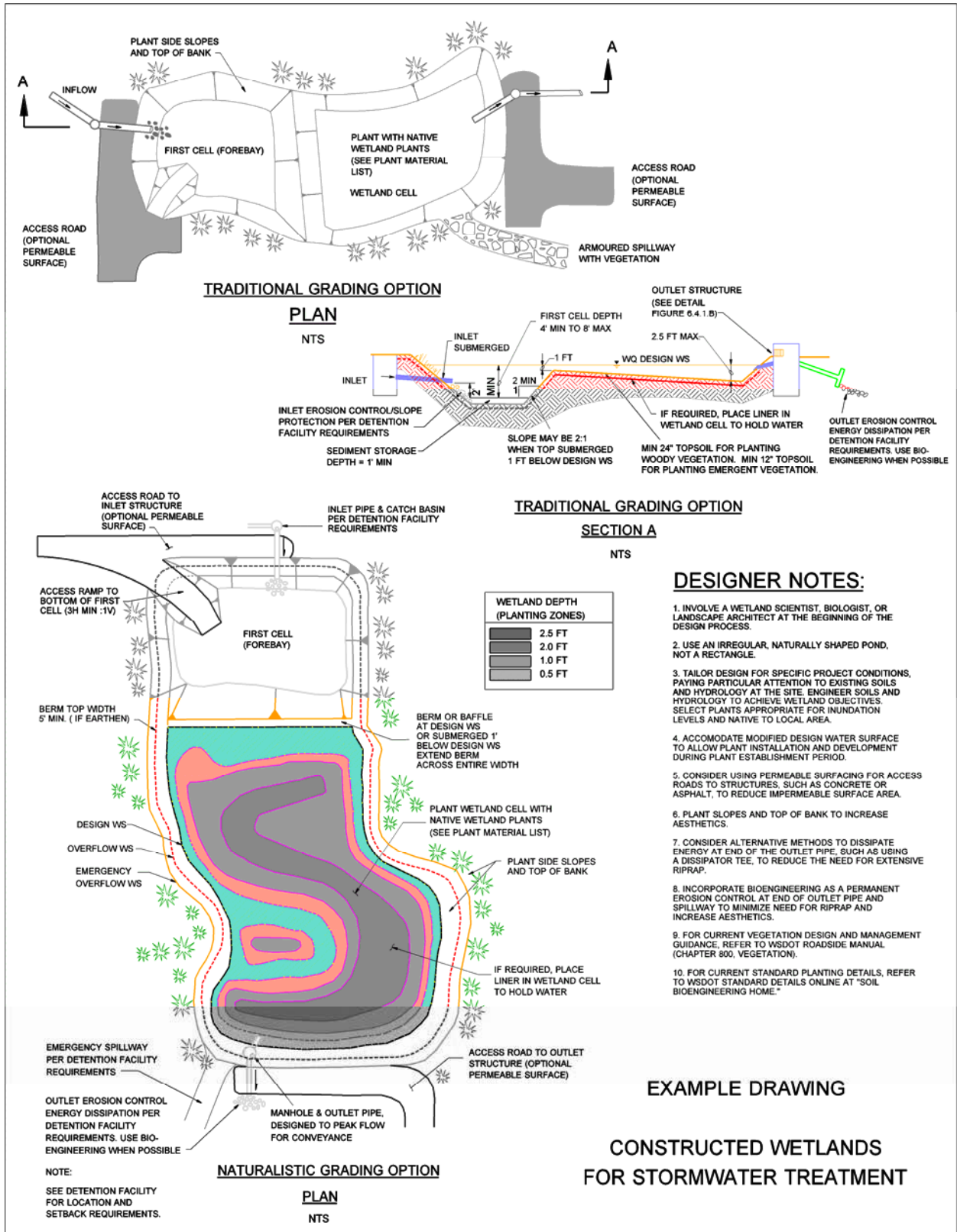

Figure RT.13.1. Constructed wetlands for stormwater treatment.

Inlet

The inlet to the presettling cell of the wetland must be submerged, with the inlet pipe invert a minimum of 2 feet from the wetland bottom (not including sediment storage). The top of the inlet pipe should be submerged at least 1 foot, if possible. The designer shall compute the hydraulic grade line (HGL) of the inlet pipe to verify backwater conditions are acceptable. (See the *Hydraulics Manual* for computing an HGL.)

Intent: The inlet is submerged to dissipate the energy of the incoming flow. The distance from the bottom is set to minimize resuspension of settled sediments. Alternative inlet designs that accomplish these objectives are acceptable.

Outlet

An outlet structure must be provided. Either a Type 2 catch basin (see the *Standard Plans*) or a manhole with a cone grate (birdcage) may be used (see Figure FC.03.3 for an illustration). No sump is required in the outlet structure for wetlands not providing detention storage. The outlet structure receives flow from the wetland outlet pipe. The birdcage opening provides an overflow route should the wetland outlet pipe become clogged. The following overflow criteria specify the sizing and position of the grate opening:

- The wetland outlet pipe (from the wetland into the control structure) must be backsloped, or have a turn-down elbow, and extend 1 foot below the runoff treatment design water surface. A floating outlet, set to draw water from 1 foot below the water surface, is acceptable if vandalism concerns are adequately addressed.

Intent: The inverted outlet pipe traps oils and floatables in the wetland.

- The wetland outlet pipe must be sized, at a minimum, to pass the runoff treatment design flow.

Note: The highest invert of the outlet pipe sets the runoff treatment design water surface elevation.

- Alternative methods to dissipate energy at the end of the outlet pipe, such as a dissipater tee, should be considered to reduce the need for extensive riprap.

Berms, Baffles, and Slopes

- The berm separating the two cells must be shaped so that its downstream side gradually slopes to form the second shallow wetland cell (see the section view on Figure RT.13.1). Alternatively, the second cell may be graded naturalistically from the top of the dividing berm (see *Sizing Procedure*, Step 6, above).
- The top of the berm must be either at the runoff treatment design water surface or submerged 1 foot below this surface, as for wet ponds. Correspondingly, the side slopes of the berm must meet the following criteria:

- If the top of the berm is at the runoff treatment design water surface, then for safety reasons the berm should not be greater than 3H:1V, just as the wetland banks should not be greater than 3H:1V if the wetland is not fenced.
- If the top of the berm is submerged 1 foot, the upstream side slope may be up to 2H:1V. If submerged, the berm is not considered accessible and the steeper slope is allowable.

Liners

If soil permeability allows sufficient water retention, lining is not necessary. In infiltrative soils, both cells of the stormwater wetland must be lined. Two types of liner are acceptable: low-permeability liners and treatment liners. To determine whether a low-permeability liner or a treatment liner is required, see Section 5-4.3.3.

Site Design Elements

Setback Requirements

- Stormwater treatment wetlands must be a minimum of 5 feet from any property line or vegetative buffer. This distance may need to be increased based on the permit requirements of the local jurisdiction.
- Stormwater treatment wetlands must be 100 feet from any septic tank or drain field, except wet vaults, which must be a minimum of 20 feet.
- The designer should request from the WSDOT Materials Lab a geotechnical report for the project that evaluates any potential structural site instability due to extended subgrade saturation and/or head loading of the permeable layer. This includes the potential impacts to downgradient properties, especially on hills with known side-hill seeps. The report should address the adequacy of the proposed stormwater treatment wetland locations and recommend the necessary setbacks from any steep slopes and building foundations.

Landscaping (Planting Considerations)

When used for stormwater treatment, stormwater wetlands incorporate some of the same design features as wet ponds. However, instead of gravity settling being the dominant treatment process, pollutant removal mediated by aquatic vegetation (and the microbiological community associated with that vegetation) becomes the dominant treatment process. Thus, water volume is not the dominant design criterion for stormwater wetlands—rather, factors that affect plant vigor and biomass are the primary concerns. It is critical to involve a wetland scientist, biologist, or landscape architect throughout the design process.

The wetland cells must be planted with emergent wetland plants following the recommendations given in Table RT.13.2 and those of a wetland specialist, biologist, or landscape architect. Plants listed in the table are for western Washington only. Local knowledge should be used to adapt this information for eastern Washington.

Table RT.13.2. Plant species recommended for stormwater treatment wetlands in western Washington.

Species	Common Name	Notes	Maximum Depth
Wetland Edge			
<i>Salix sitchensis</i>	Sitka willow		
<i>Cornus sericea</i>	Red osier dogwood		
Inundation to 1 Foot			
<i>Agrostis exarata</i> ^a	Spike bent grass	Prairie to coast	to 2 feet
<i>Carex stipata</i>	Sawbeak sedge	Wet ground	
<i>Eleocharis palustris</i>	Spike rush	Margins of wetlands, wet meadows	to 2 feet
<i>Glyceria occidentalis</i>	Western mannagrass	Marshes, wetland margins	to 2 feet
<i>Juncus tenuis</i>	Slender rush	Wet soils, wetland margins	
<i>Oenanthe sarmentosa</i>	Water parsley	Shallow water along stream and wetland margins; needs saturated soils all summer	
<i>Scirpus atrocinctus</i> (formerly <i>S. cyperinus</i>)	Woolgrass	Tolerates shallow water; tall clumps	
<i>Scirpus microcarpus</i>	Small-fruited bulrush	Wet ground to 18 inches depth	18 inches
<i>Sagittaria latifolia</i>	Arrowhead		
Inundation 1 to 2 Feet			
<i>Agrostis exarata</i> ^a	Spike bent grass	Prairie to coast	
<i>Alisma plantago-aquatica</i>	Water plantain		
<i>Eleocharis palustris</i>	Spike rush	Margins of wetlands, wet meadows	
<i>Glyceria occidentalis</i>	Western mannagrass	Marshes, wetland margins	
<i>Juncus effuses</i>	Soft rush	Wet meadows, pastures, wetland margins	
<i>Scirpus microcarpus</i>	Small-fruited bulrush	Wet ground to 18 inches depth	18 inches
<i>Sparganium emersum</i>	Bur-reed	Shallow standing water, saturated soils	
Inundation 1 to 3 Feet			
<i>Carex obnupta</i>	Slough sedge	Wet ground or standing water	1.5 to 3 feet
<i>Beckmania syzigachne</i> ^a	Western sloughgrass	Wet prairie to wetland margins	
<i>Scirpus acutus</i> ^b	Hardstem bulrush	Single tall stems, not clumping	to 3 feet
<i>Scirpus validus</i> ^b	Softstem bulrush		
Inundation Greater Than 3 Feet			
<i>Nuphar polysepalum</i>	Spatterdock	Deep water	3 to 7.5 feet
<i>Nymphaea odorata</i> ^a	White waterlily	Shallow to deep wetlands	to 6 feet

Primary sources: Metro 1990; Hortus Northwest 1991; Hitchcock and Cronquist 1973.

^a Non-native species. *Beckmania syzigachne* is native to Oregon. Native species are preferred.

^b *Scirpus* tubers must be planted shallower for establishment and protected from foraging waterfowl until established. Emerging aerial stems should project above water surface to allow oxygen transport to the roots.

Note: Cattails (*Typha latifolia*) are not recommended. They tend to crowd out other species in constructed wetlands, as well as escape to natural wetlands where they do the same. In addition, the shoots die back each fall, resulting in oxygen depletion in the treatment wetland unless they are removed.

Soil Amendments and Protection

The method of construction for soil/landscape systems can affect natural selection of specific plant species. Consult a soil restoration or wetland soil scientist for site-specific soil amendment recommendations. The formulation should encourage desired species and discourage undesired species. Soils should be stabilized with permanent or temporary cover to prevent washout due to storm flows.

Soil Preparation

Incorrect control of soil moisture is the most frequent cause of failure to establish wetland plants. Inadequate water results in desiccation of roots. Too much water results in oxygen depletion in the root zone, submergence and drowning or flotation of plants, and/or slow growth or plant death.

To maintain adequate soil moisture during plant establishment, a reliable and adequate supply of water for site irrigation is needed. When feasible, a water source for plant establishment is usually the stormwater treated in the wetland. However, if stormwater is not available, another irrigation source must be identified to maximize planting success. Adequate pumps, piping, and sprinklers or hoses must be provided to allow even flow distribution.

According to Kadlec and Knight (1996), the recommended sequence for maintaining soil moisture for wetland planting starts with initial saturation of soil by sprinkling or flood irrigation. For optimal plant growth, the soil should be fully or partially saturated with water immediately before planting and should not be allowed to completely dry out anytime after planting. High soil moisture must be maintained after planting for the first few weeks without creating flooded conditions for more than a few hours. The best method to maintain soil saturation without excessive flooding is to start planting at the downgradient end of the wetland and continue planting upgradient, while gradually raising water levels using the wetland outlet water level controls or gravity drain if possible. When planting is complete, water levels can be dropped or raised as needed to maintain saturated soil conditions. Sprinklers can also be used to irrigate evenly over planted areas.

After an entire cell is planted, the water should be maintained at a level that ensures all areas of the cell continue to have saturated soil conditions between waterings. This can be achieved by (1) flood-irrigating the entire cell with enough water to allow infiltration or evapotranspiration to eliminate the applied surface water within one or two days, or (2) distributing water through the inlet distribution structures or down the embankment side slopes and allowing this water to resaturate the wetland soils as it sheet-flows across the wetland to the outlet. Weirs or outlet water control gates should be removed or left open during plant establishment to prevent flooding if rainfall is high or if a sprinkler or irrigator is accidentally left running. At no time should flood irrigation result in complete submergence of aboveground portions of installed plants. Permits may be required to use water from nearby natural aquatic water bodies for temporary irrigation purposes.

As the wetland plants grow, they have an increased ability to transport oxygen to the root zone from their leaves; thus, the plants are able to withstand longer periods of flooding. However, the best technique for establishing rapid plant cover is to maintain saturated soil conditions without surface flooding. The higher soil oxygen condition resulting from the absence of floodwaters allows maximum root metabolism, effective nutrient use, and rapid development of the plants within the wetland. This soil condition should optimally be maintained until plants achieve complete cover (100%) or at least the minimum cover required for system startup (about 60% to 80%).

Design and construction should allow the design water surface to be temporarily modified to enable plant installation and establishment before the system is brought on-line. Several strategies may be available depending on the project situation, schedule, and site conditions.

- If the system must go on-line the same year it is constructed, plant the constructed wetland cell in the spring or early summer and irrigate all summer to maintain saturated soils without plant submergence or flotation until plants are sufficiently developed to operate the system in the fall.
- If the system can remain off-line all winter, plant the constructed wetland cell in the fall, monitor water conditions, and maintain saturated soils without plant submergence or flotation, by irrigating or draining as necessary, until plants are sufficiently developed to allow operation of the system the following year. Note: Wetland plants planted later in the summer or fall have their growth interrupted by cold weather and decreasing day length (Kadlec and Knight 1996).

Several methods could be used to temporarily control water levels during plant establishment, depending on project conditions.

- Build the treatment wetland before the project is started so that wetland plants are established before flows are introduced.
- Keep the treatment wetland off-line until wetland plants become established by bypassing the treatment wetland.
- Temporarily operate the drain of the treatment wetland as the outlet to maintain water surface elevations below the design water surface level.
- Plant early in the fall or late in the spring when water surface elevations are naturally lower.
- Pump out water to lower the wetland cell for planting and establishment.

A wetland treatment system can typically begin operation when plant cover is at least 60% to 80%, which may require at least three to four months of active growth. If this coverage is achieved during the first growing season after planting, the wetland system can begin operating during the ensuing fall.

Planting

- Seed embankment areas above the runoff treatment design water surface and below the emergency overflow water level. Areas with permanent pools that are protected from erosion need not be seeded.
- Consider planting conifer or columnar deciduous trees along the west and south sides of wetlands to reduce thermal heating—except that no trees or shrubs may be planted on berms meeting the criteria of dams regulated for safety. In addition to shade, trees and shrubs also discourage waterfowl use and the attendant phosphorus enrichment problems they cause. Trees should be set back so that the branches will not extend over the wetland.

Intent: Conifer trees or shrubs are preferred to avoid problems associated with leaf drop. Columnar deciduous trees (such as hornbeam and Lombardy poplar) typically have fewer leaves than other deciduous trees.

- Include trees and shrubs on slopes and on top of banks to increase aesthetics. If the treatment wetland discharges to a phosphorus-sensitive lake or natural wetland, shrubs that form a dense cover should be planted on slopes above the runoff treatment design water surface on at least three sides. For banks that are berms, no planting is allowed if the berm is regulated by dam safety requirements. The purpose of planting is to discourage waterfowl use of the wetland and to provide shading. Some suitable trees and shrubs include vine maple (*Acer circinatum*), wild cherry (*Prunus emarginata*), willow (*Salix* sp.), red osier dogwood (*Cornus stolonifera*), California myrtle (*Myrica californica*), Indian plum (*Oemleria cerasiformis*), and Pacific yew (*Taxus brevifolia*).

General Maintenance Requirements

For general maintenance requirements, see Section 5-3.6.1. The following replaces or supplements the guidelines found in Section 5-3.6.1:

- A drain in the wetland cell (or cells) may also be necessary to avoid surface flooding during wetland plant installation and establishment.

Recommended Design Features

The following design features should be incorporated where possible to enhance aesthetics:

- Provide maintenance access to shallow pool areas enhanced with emergent wetland vegetation. This allows the wetland to be accessible for vegetation maintenance without incurring safety risks.
- Provide side slopes that are sufficiently gentle to avoid the need for fencing (3H:1V or flatter).
- Provide visual enhancement with clusters of trees and shrubs. On most wetland sites, it is important to amend the soil before planting because

wetlands are typically placed well below the native soil horizon in very poor soils. Make sure dam safety restrictions against planting do not apply.

- Consider extending the access and maintenance road along the full length of the treatment wetland. Consider placing finely ground bark, wood chips, or other permeable surfacing over the road surface to reduce runoff.
- Where right of way allows, orient the wetland length along the direction of prevailing summer winds (typically west or southwest) to enhance wind mixing.

Construction

- Construction and maintenance considerations are the same as those for wet ponds (see BMP RT.12).
- The naturalistic grading alternative (see Figure RT.13.1) can be constructed by first excavating the entire area to the 1.5-foot average depth. Soil subsequently excavated to form deeper areas can then be deposited to raise other areas until the distribution of design depths is achieved.
- Ideally, a period of approximately one year is desirable to establish plants before the system goes on-line.

Nuisance Control

Beavers

Information on beaver control can be found at the following websites:

☞ www1.co.snohomish.wa.us/Departments/Public_Works/Divisions/SWM/Services/Landowners/Streamside/FAQ/FAQ_Living_With_Beavers.htm

☞ dnr.metrokc.gov/wlr/Dss/beavers/beaverintro.htm

Mosquitoes

A recent study in California provides evidence that interspersing stands of emergent vegetation with areas of open water is effective in reducing mosquito production. Areas of relatively deep open water can decrease vegetation density and limit the accumulation of floating mats of root masses and dead vegetation. These characteristics were found to reduce mosquito refuge areas and increase mosquito predator habitat (Thullen et al., 2002).

The creation of hummocks on which wetland plants are established is a design option to create areas of open water. A constant water depth of 3 to 6 feet between hummocks is usually sufficient to effectively limit emergent vegetation propagation. These deep pool areas are in addition to the surface area requirements listed in Table RT.13.1.

CO.02 – Combined Stormwater Treatment Wetland/Detention Pond

Introduction

General Description

The *combined stormwater treatment wetland/detention pond* is best described as a wetland system that provides for the extended detention of runoff during and following storm events. This BMP is useful in areas with limited right of way where separate runoff treatment and flow control facilities are not feasible. It is recommended that all BMPs that use permanent wet pools use facility liners (see Section 5-4.3.3).

Design Flow Elements

Flows to Be Treated

The sizing procedure for the combined stormwater treatment wetland and detention pond is identical to that outlined for stormwater wetlands (see BMP RT.13) and for combined wet/detention ponds (see BMP CO.01). Follow the procedures outlined in those sections to determine the stormwater wetland size.

Structural Design Considerations

Geometry

The design criteria for detention ponds (see BMP FC.03) and constructed stormwater treatment wetlands (see BMP RT.13) must both be met, except for the following modifications or clarifications:

- The minimum sediment storage depth in the first cell is 1 foot. The 6 inches of sediment storage required for detention ponds does not need to be added to this, nor does the 6 inches of sediment storage in the second cell of detention ponds need to be added.

Intent: Because emergent plants are limited to shallower water depths, the deeper water created before sediments accumulate is considered detrimental to robust emergent growth. Therefore, sediment storage is confined to the first cell, which functions as a presettling cell.

- The inlet and outlet criteria for constructed stormwater treatment wetlands (see BMP RT.13) apply, with the following modifications:
 - A sump must be provided in the outlet structure of combined facilities.
 - The detention flow restrictor and its outlet pipe must be designed according to the requirements for detention ponds (see BMP FC.03).

Groundwater Issues

Live storage requirements are the same as for detention ponds (see BMP FC.03). This does not apply to the constructed stormwater treatment wetlands' dead storage component.

Site Design Elements

Landscaping (Planting Considerations)

The landscaping requirements for constructed stormwater treatment wetlands (see BMP RT.13) are modified to use the plants in Table CO.02.1, which are better adapted to water level fluctuations in combined stormwater treatment wetlands/detention ponds.

Table CO.02.1. Wetland plants adapted to water level fluctuations.

Species	Common Name	Depth (feet)
<i>Scirpus acutus</i>	Hardstem bulrush	2–6
<i>Scirpus microcarpus</i>	Small-fruited bulrush	1–2.5
<i>Sparganium emersum</i>	Bur-reed	1–2
<i>Sparganium eurycarpum</i>	Bur-reed	1–2
<i>Veronica sp.</i>	Marsh speedwell	0–1

In addition, the shrub *Spirea douglasii* (Douglas spirea) may be used in combined facilities.

Soil Preparation

The water level fluctuation restrictions for constructed stormwater treatment wetlands (see BMP RT.13) are modified as follows:

- The difference between the runoff treatment design water surface and the maximum water surface associated with the 2-year storm event must not be greater than 3 feet. If this restriction cannot be met, the area of the stormwater wetland must be increased. The additional area may be placed in the first cell, second cell, or both. If placed in the second cell, the additional area need not be planted with wetland vegetation or counted in the calculations for average depth.

Intent: This criterion is intended to dampen the most extreme water level fluctuations expected in combined facilities to better ensure fluctuation-tolerant wetland plants survive in the facility. It is not intended to protect native wetland plant communities and is not to be applied to natural wetlands.

General Maintenance Requirements

For general maintenance criteria for detention ponds and constructed stormwater wetlands, see Section 5-3.6.1.

5-4.1.5 Oil Control BMPs

RT.22 – Oil Containment Boom



Oil Containment Boom Along I-5 in Thurston County.

Introduction

General Description

The *oil containment boom* is a weather-resistant, hydrophobic, absorbent-filled boom for removing hydrocarbon sheens from water.

Applications and Limitations

Oil containment booms can be used to remove oil from stormwater facilities to meet performance goals at locations where oil control is required, as described in Table 3-1.

Oil containment boom technology offers the following advantages over other treatment options:

- Fully functional at flow rates exceeding treatment flow criteria
- Easy and complete removal and disposal of absorbed oil
- Higher reliability because sediment clogging is avoided
- Effectiveness easily assessed due to aboveground installation
- Reduced exposure of maintenance workers to traffic and confined-space hazards

- Lower material and labor costs (6 to 17 times lower than oil/water separators, sand filters, and catch basin inserts)
- No capital improvement costs
- No additional right of way requirements or conflicts with buried structures

Structural Design Considerations

Geometry

The boom must be cylindrical, with a minimum diameter of 2 inches. It should be installed near the outlet end of the facility so that the oil has a maximum amount of time to rise to the water surface. Maximizing boom distance from inlet currents also maximizes contact time between the boom and the oil. The boom must span the entire width of ponds when they are filled to capacity. The boom must be placed so that it is in direct contact with the water across the entire water surface. In treatment ponds, the boom must be installed diagonally across the water surface to maximize contact area and contact time between hydrocarbons and the boom. When used in a vault, the boom must completely encircle the outlet structure (see Figure RT.22.1).

Materials

The absorbent material must consist of high-molecular-weight polymers capable of absorbing (1) C5-C18 hydrocarbons associated with fuels, and (2) longer chain hydrocarbons with frequently attached cyclic hydrocarbon structures associated with lubricating oils.

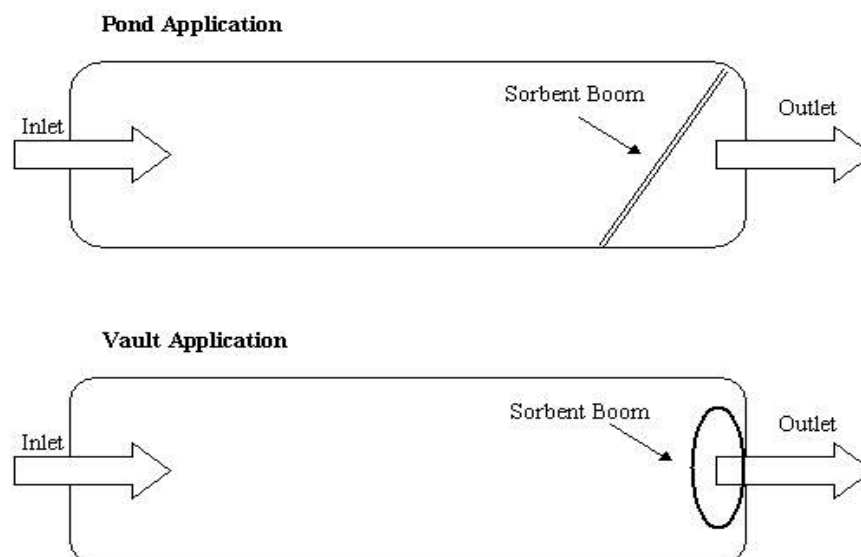

Figure RT.22.1. Oil containment boom.

The absorbent material must exhibit the following characteristics:

- Absorb and solidify a minimum of three times its weight in liquid hydrocarbons.
- Have sufficient buoyancy at the exhausted condition to continue to trap oil.
- Irreversibly absorb and permanently hold the hydrocarbons so that oil leachate is not released from the sorbent. U.S. EPA guidelines for solidified hazardous waste without chemical bonds being formed or broken must also be met.
- Contain a minimum of 99% active ingredient and no leachable toxicant to fish and other aquatic life. The supplier must provide appropriate information demonstrating that toxicity will not be a problem.

The absorbent boom cover fabric must meet the following criteria:

- Be fabricated of photo-resistant mesh that meets the ultraviolet (UV) stability requirement for permanent erosion control blankets in Section 9-14.5 of the *Standard Specifications*.
- Be sized to allow for the expansion of the absorbent material to hold the specified absorption volume per foot.

Additional requirements for materials related to booms include the following:

- Booms must include a weather-resistant tag to enable labeling with installation and inspection dates for tracking long-term effectiveness and maintenance activities.
- Boom ends must be configured so that they can be secured to immobile structures or metal stakes with weather-resistant rope.

5-4.2 Flow Control Methods

The primary function of the BMPs listed in this section is to meet Minimum Requirement 6 (Flow Control) in Section 3-3.6.

5-4.2.1 Infiltration BMPs

IN.01 – Bioinfiltration Pond (eastern Washington only)

Introduction

General Description

Bioinfiltration ponds, also known as bioinfiltration swales or grass percolation areas, combine grasses (or other vegetation) and soils to remove stormwater pollutants by percolation into the ground. Their pollutant removal mechanisms include filtration, soil

sorption, and uptake by vegetative root zones. Bioinfiltration ponds have been used in Spokane County for many years to treat urban stormwater and recharge the groundwater.

In general, bioinfiltration ponds are used for treating stormwater runoff from roofs, roads, and parking lots. Flows greater than the design treatment flow typically overflow through an appropriate conveyance system to a higher permeability (flow control) infiltration BMP such as a drywell or infiltration pond or to a surface water discharge point with flow control as necessary (see Figure IN.01.1). Note: Underground injection control (UIC) regulations apply to the drywell.

Applications and Limitations

Bioinfiltration ponds can be used to meet basic and enhanced runoff treatment objectives and oil control for high-use roads (see Table 3-1). Although bioinfiltration ponds treat runoff by infiltration through soil, the infiltration capacity of these facilities is usually not sufficient to provide flow control to meet the criteria of Minimum Requirement 6 (see Section 3-3.6). Unless a very large area is available for the shallow water depth required of a bioinfiltration pond, flow control must be implemented using a different facility.

Bioinfiltration ponds require moderately permeable soil for proper function. For general site suitability criteria for infiltration facilities, see BMP IN.02, Infiltration Pond. Additional criteria for runoff treatment are presented in Section 4-5.1.

Presettling/Pretreatment

Pretreatment should be considered to prevent the bioinfiltration pond treatment soil from clogging. (See Section 5-4.3.1 for pretreatment design criteria.)

Design Flow Elements

Flows to Be Treated

Bioinfiltration ponds are designed as volume-based infiltration treatment facilities. The runoff volume to be treated by a bioinfiltration pond is based on hydrologic models, such as SCS or SBUH. Design storm volumes are discussed in Section 3-3.5 under Minimum Requirement 5, and hydrologic methods are presented in Section 4-5.

Structural Design Considerations

Geometry

Bioinfiltration pond sizing methods are the same as those for infiltration ponds (see BMP IN.02) designed for runoff treatment, except for the following:

- Drawdown time for the maximum ponded volume is 72 hours (maximum) following the design storm event.
- The maximum ponded level is 6 inches, prior to overflow to a drywell or other infiltrative or overflow facility.

- The swale bottom should be flat with a longitudinal slope less than 1%.
- A concrete or riprap apron shall be provided at the curb opening to prevent vegetation from blocking the inlet.
- The treatment soil should be at least 6 inches thick with a cation exchange capacity (CEC) of at least 5 milliequivalents per 100 grams of dry soil, organic content of at least 1%, and sufficient target pollutant loading capacity (see *Criteria for Assessing the Trace Element Removal Capacity of Bio-filtration Systems*, Stan Miller, Spokane County, June 2000).
- Other combinations of treatment soil thickness, CEC, and organic content design factors may be considered if it is demonstrated that the soil and vegetation will provide a target pollutant loading capacity and performance level acceptable to the local jurisdiction.
- The treatment zone depth of 6 inches or more should contain sufficient organics and texture to ensure good vegetation growth.
- The average infiltration rate of the 6-inch-thick layer of treatment soil should not exceed 1 inch/hour for a system relying on the root zone to enhance pollutant removal. Furthermore, a maximum infiltration rate of 2.4 inches per hour is applicable and the site suitability criteria in Section 4-5.1 must also be applied.
- Native grasses, adapted grasses, or other vegetation with significant root mass should be used. For eastern Washington, grasses should be drought tolerant or irrigation should be provided.
- Pretreatment may be used to prevent clogging of the treatment soil and vegetation by debris, TSS, and oil and grease.

Identify pollutants, particularly in industrial and commercial area runoff, that could cause a violation of the Ecology groundwater quality standards (WAC 173-200). Include appropriate mitigation measures (for example, pretreatment or source control) for the pollutants.

Materials

For runoff treatment, soils must meet the criteria described in BMP IN.02, Infiltration Pond, and the *Site Suitability Criteria* in Section 4-5.1.

Groundwater Issues

Groundwater issues for bioinfiltration ponds are the same as those for infiltration ponds (see BMP IN.02).

Consider the potential impact of roadway deicers on potable water wells when siting the bioinfiltration pond. Mitigation measures must be implemented if infiltration of roadway deicers could cause a violation of groundwater quality standards.

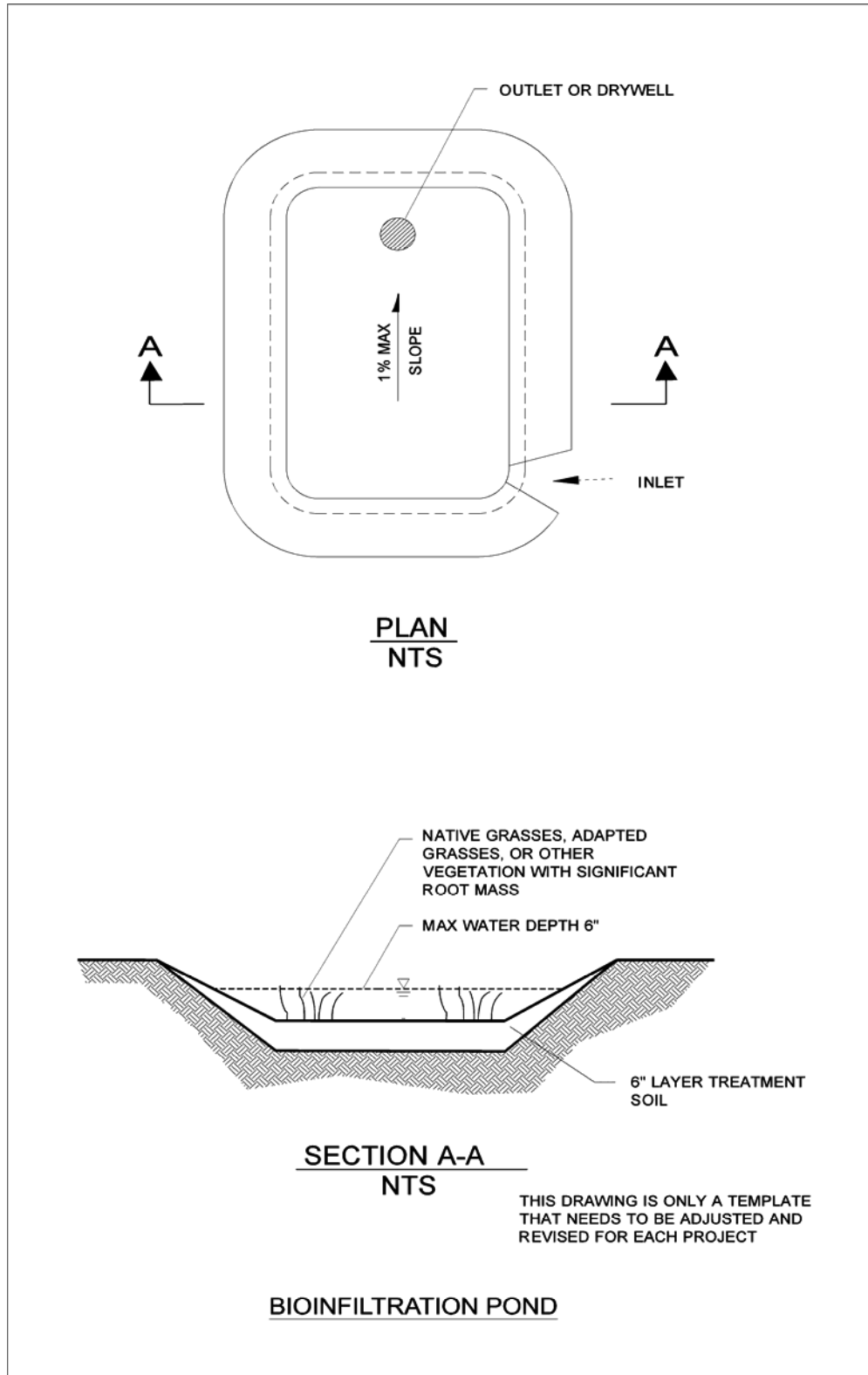

Figure IN.01.1. Bioinfiltration pond.

Site Design Elements

Conduct initial excavation to within 1 foot of the final elevation of the floor of the bioinfiltration pond. Defer final excavation to the finished grade until all disturbed areas in the upgradient drainage area have been stabilized or protected. The final phase of excavation should remove all accumulated sediment. After construction is completed, prevent sediment from entering the bioinfiltration pond by first conveying the runoff water through an appropriate pretreatment system such as a presettling basin.

Bioinfiltration ponds, as with all types of infiltration facilities, should generally not be used as temporary sediment traps during construction. If a bioinfiltration pond is to be used as a sediment trap, do not excavate to final grade until after the upgradient drainage area has been stabilized. Remove any accumulation of silt in the swale before putting the swale into service.

Relatively light-tracked equipment is recommended for excavation to avoid compacting the floor of the bioinfiltration pond. Consider the use of draglines and trackhoes. The bioinfiltration pond area should be flagged or marked to keep equipment away.

Setback Requirements

Setback requirements for bioinfiltration ponds are the same as those for infiltration ponds (see BMP IN.02).

Right of Way

Right of way requirements for bioinfiltration ponds are the same as those for detention ponds (see BMP FC.03).

Landscaping (Planting Considerations)

Use native or adapted grass species for the entire area of the bioinfiltration pond.

Maintenance Access Roads (Access Requirements)

Access requirements for bioinfiltration ponds are the same as those for infiltration ponds (see BMP IN.02).

IN.02 – Infiltration Pond



Infiltration Pond Along SR 510 in Thurston County.

Introduction

General Description

Infiltration ponds for flow control are earthen impoundments used for the collection, temporary storage, and infiltration of incoming stormwater runoff to groundwater (see Figure IN.02.1). Infiltration ponds can also be designed to provide runoff treatment (see Section 4-5.1).

Applications and Limitations

Infiltration of runoff is the preferred method of flow control. Runoff in excess of the infiltration capacity must be detained and released in compliance with the flow control requirement described in Section 3-3.6 under Minimum Requirement 6.

Site Suitability Criteria

Infiltration ponds require permeable soil conditions for proper function. For a site to be considered suitable for an infiltration pond, the design infiltration rate must be at least 0.5 inches per hour. Infiltration can still be considered in the design if the infiltration rate is less, but infiltration would be considered a secondary function in this case. Additional site suitability criteria are specified in Section 4-5.1.

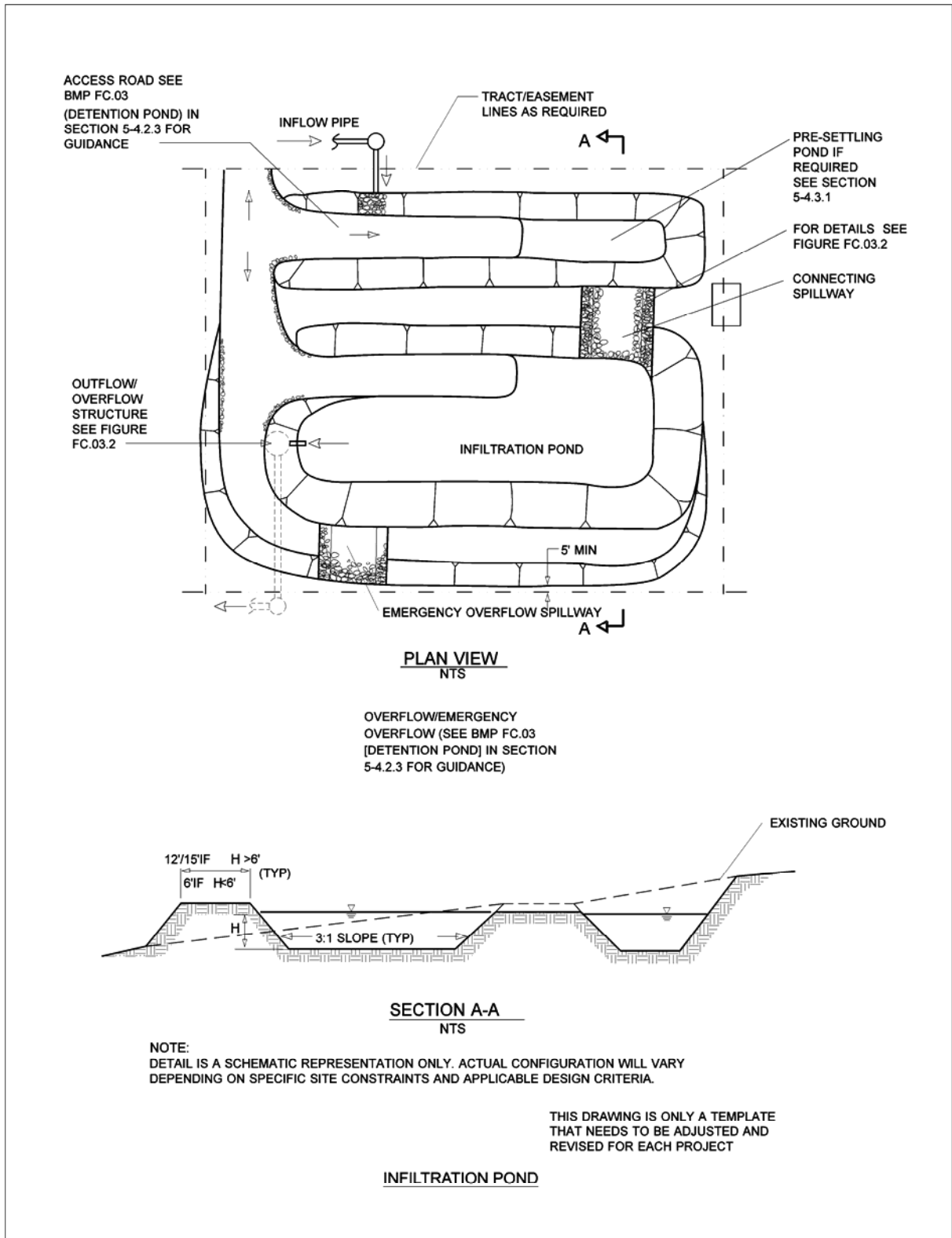

Figure IN.02.1. Infiltration pond.

The base of all infiltration ponds must typically be at least 5 feet above the seasonal high-water mark, bedrock (or hardpan), or other low-permeability layer. This vertical distance may be reduced to a minimum of 3 feet if the following apply:

- The groundwater mounding analysis, volumetric receptor capacity, and design of the overflow or bypass structures are judged by the designer to be adequate to prevent overtopping
- The facility meets all other criteria listed in this BMP description

Presettling/Pretreatment

Infiltration ponds should follow a runoff treatment or pretreatment facility to prevent sediment buildup and clogging of the infiltrative soils. A presettling cell can be included in the infiltration pond design, as shown in Figure IN.02.1. (See BMP RT.24, Presettling/Sedimentation Basin, for design criteria.) If an infiltration pond cannot meet the site suitability criteria for treatment, a minimum of basic treatment must be provided prior to infiltration. (See Section 5-3.4 for additional criteria.)

Design Flow Elements

Flows to Be Infiltrated

Site runoff should be infiltrated to the extent that occurred before the site was developed. Runoff in excess of the infiltration capacity must be detained and released in compliance with the flow control requirement described in Section 3-3.6 under Minimum Requirement 6. (See Section 4-5 for hydrologic analysis methods applicable to flow control for surface discharges.)

For a site to be considered suitable for an infiltration pond, the design infiltration rate must be at least 0.5 inches/hour. Infiltration can still be considered in flow control facility design if the infiltration rate is less than this, but infiltration must be considered to be a secondary function in that case. A pond must be designed to a desirable depth of 3 feet and a maximum depth of 6 feet, with a minimum freeboard of 1 foot above the design water level (1 foot above the 50-year water surface elevation for western Washington and 1 foot above the 25-year water surface elevation for eastern Washington). For a web link to examples of infiltration pond design and associated spreadsheets, see Appendix 4A. Please note that examples are separated into western Washington examples on MGSFlood and eastern Washington examples on StormShed.

1. For western Washington, an infiltration flow control pond must be designed using a continuous hydrograph model to infiltrate sufficient volume so that the overflow matches the duration standard (or 100% of the runoff volume).
2. For eastern Washington, an infiltration flow control pond must be designed using a single-event hydrograph model to infiltrate the runoff treatment volume out of the pond within 72 hours. An infiltration flow control pond must be designed using a

single-event hydrograph model to infiltrate the 25-year storm with an overflow for the higher events or infiltrate 100% of the storm runoff volume.

Outlet Control Structure

Runoff in excess of the infiltration capacity must be detained and released in compliance with the flow control requirement described in Section 3-3.6 under Minimum Requirement 6. Outlet control structure design criteria are provided in BMP FC.03, Detention Pond.

Site Design Elements

Setback Requirements

Setback requirements for infiltration vaults are the same as those for infiltration ponds (see BMP IN.02).

Flow Splitters

For an infiltration pond designed to serve only as a runoff treatment facility, the pond may be located off-line by installing a flow splitter upstream of the treatment facility. The splitter must direct all flows up to the water quality design flow rate into the infiltration facility. The facility must be designed to infiltrate all water directed to it. All bypassed flow must be conveyed to a flow control facility unless it is directly discharged to an exempt water body. (See Section 5-4.3.4 for flow splitter design criteria.)

Note: Infiltration ponds designed for flow control must be located on-line.

Emergency Overflow Spillway

A nonerodible outlet or spillway with a firmly established elevation must be constructed to discharge overflow to the downstream conveyance system, as described in BMP FC.03, Detention Pond. Ponding depth, drawdown time, and storage volume are calculated from the overflow elevation.

Structural Design Considerations

Geometry

For detailed criteria on sizing infiltration facilities, see Section 4-5. Infiltration ponds must meet the following criterion:

- The slope of the floor of an infiltration pond must not exceed 3% in any direction.

Eastern Washington

For cold climate infiltration pond design criteria, refer to Ecology's SMMEW.

Embankments

Requirements for infiltration pond embankments are the same as those for BMP FC.03, Detention Pond. In addition, the site geotechnical investigation must include:

- Stability analysis of side slopes for ponds and the potential to activate landslides in the vicinity of the facility during construction or during service.
- Seepage analysis of any berms or dams required by the facility to retain stormwater.

Liners

The floor of infiltration ponds can be covered with a 6- to 12-inch layer of filter material such as coarse sand, or a suitable filter fabric liner may be used to help prevent buildup of impervious deposits on the soil surface. A nonwoven geotextile that functions sufficiently without plugging should be selected (see underground drainage geotextile specifications in Section 9-33 of the *Standard Specifications*). With this underlying geotextile, the filter layer can be readily replaced or cleaned if it becomes clogged.

Groundwater Issues

A site is not suitable if the infiltration of stormwater may cause a violation of Ecology groundwater quality standards (see Chapter 2 for guidelines). Local jurisdictions should be consulted for applicable pollutant-removal requirements upstream of the infiltration facility and to determine whether the site overlies a sensitive groundwater recharge area, sole-source aquifer, or wellhead protection zone.

Site Design Elements

Initial excavation should be conducted to within 1 foot of the final elevation of the infiltration pond floor. Final excavation to the finished grade should be deferred until all disturbed areas in the upgradient drainage area have been stabilized or protected. The final phase of excavation should remove all accumulated sediment.

Infiltration ponds, as with all types of infiltration facilities, should generally not be used as temporary sediment traps during construction. If an infiltration pond is to be used as a sediment trap, it must not be excavated to final grade until after the upgradient drainage area has been stabilized. Any accumulation of silt in the pond must be removed before the pond is put into service.

Low-ground-pressure equipment is recommended for excavation to avoid compacting the floor of the infiltration pond. The use of draglines and trackhoes should be considered. The infiltration area should be flagged or marked to keep equipment away.

Setback Requirements

Setback requirements for infiltration ponds are generally required by local regulations, Uniform Building Code requirements, or other state regulations. The following setback criteria are provided as guidelines:

- For infiltration facilities, the designer should request from the WSDOT Materials Lab a geotechnical report for the project that evaluates any potential structural site instability due to extended subgrade saturation and/or head loading of the permeable layer, including the potential impacts to downgradient properties, especially on hills with known side-hill seeps. The report should address the adequacy of the proposed infiltration pond locations and recommend the necessary setbacks from any steep slopes and building foundations.
- Infiltration facilities should be set back at least 100 feet from drinking water wells, septic tanks or drain fields, and springs used for public drinking water supplies. Infiltration facilities upgradient of drinking water supplies and within 1-, 5-, and 10-year time of travel zones must comply with health department requirements (Washington Wellhead Protection Program, WAC 246-290-135).
- Additional setbacks must be considered if roadway deicers or herbicides are likely to be in the influent to the infiltration system.
- Infiltration facilities must be located at least 20 feet downslope and 100 feet upslope from building foundations.
- Infiltration facilities must be located at least 20 feet from a native growth protection easement (NGPE).
- Infiltration facilities must be a minimum of 5 feet from any property line and/or vegetative buffer. This distance may need to be increased based on permit conditions required by regulations of the local jurisdiction.

Landscaping (Planting Considerations)

The interior of the infiltration pond, as well as surrounding berms, spoil areas, borrow areas, and other disturbed areas, should be stabilized and planted, preferably with grass. Without healthy vegetation, the surface soil pores quickly plug. The use of slow-growing, stoloniferous grasses permits long intervals between mowing. Refer to BMP FC.03, Detention Pond, for seed mixture recommendations.

Fencing

Fencing requirements for an infiltration pond are identical to those of BMP FC.03, Detention Pond.

Signage

Signage requirements for an infiltration pond are identical to those of BMP FC.03, Detention Pond.

Maintenance Access Roads (Access Requirements)

Vehicle access must be provided to maintain the forebay (presettling basin) area and not disturb vegetation or resuspend sediment.

Operation and Maintenance

Infiltration ponds, as with all BMPs, must have routine inspection and maintenance designed into the life performance of the facility. (See Section 5-5 for more details.)

IN.03 – Infiltration Trench

Introduction

General Description

Infiltration trenches are long, narrow, stone-filled trenches used for the collection, temporary storage, and infiltration of stormwater runoff to groundwater. They can be a useful alternative for sites with constraints that make siting an infiltration pond difficult. Infiltration trenches may be placed beneath parking areas, along the site periphery, or in other suitable linear areas. They may also be designed for runoff treatment (see Section 4-5.1). For infiltration trench concept details, see Figures IN.03.1 through IN.03.5.

Applications and Limitations

Infiltration of runoff is the preferred method of flow control following appropriate runoff treatment. Runoff in excess of the infiltration capacity must be detained and released in compliance with the flow control requirement described in Section 3.3.6 under Minimum Requirement 6.

This BMP is considered a subsurface infiltration facility and its use may be subject to the rules governing Class V underground injection wells, but only if it includes the use of a perforated pipe. This type of stormwater facility must be registered through Ecology's UIC (Underground Injection Control) Program. For more information on UIC requirements, see Section 4-5.4.

Site Suitability Criteria

Site suitability criteria are the same as those for infiltration ponds (see BMP IN.02).

Presettling/Pretreatment

Infiltration trenches should follow a runoff treatment or pretreatment facility to prevent sediment buildup and clogging of the trench. (See BMP RT.24, Presettling/Sedimentation Basin, for pretreatment design criteria.)

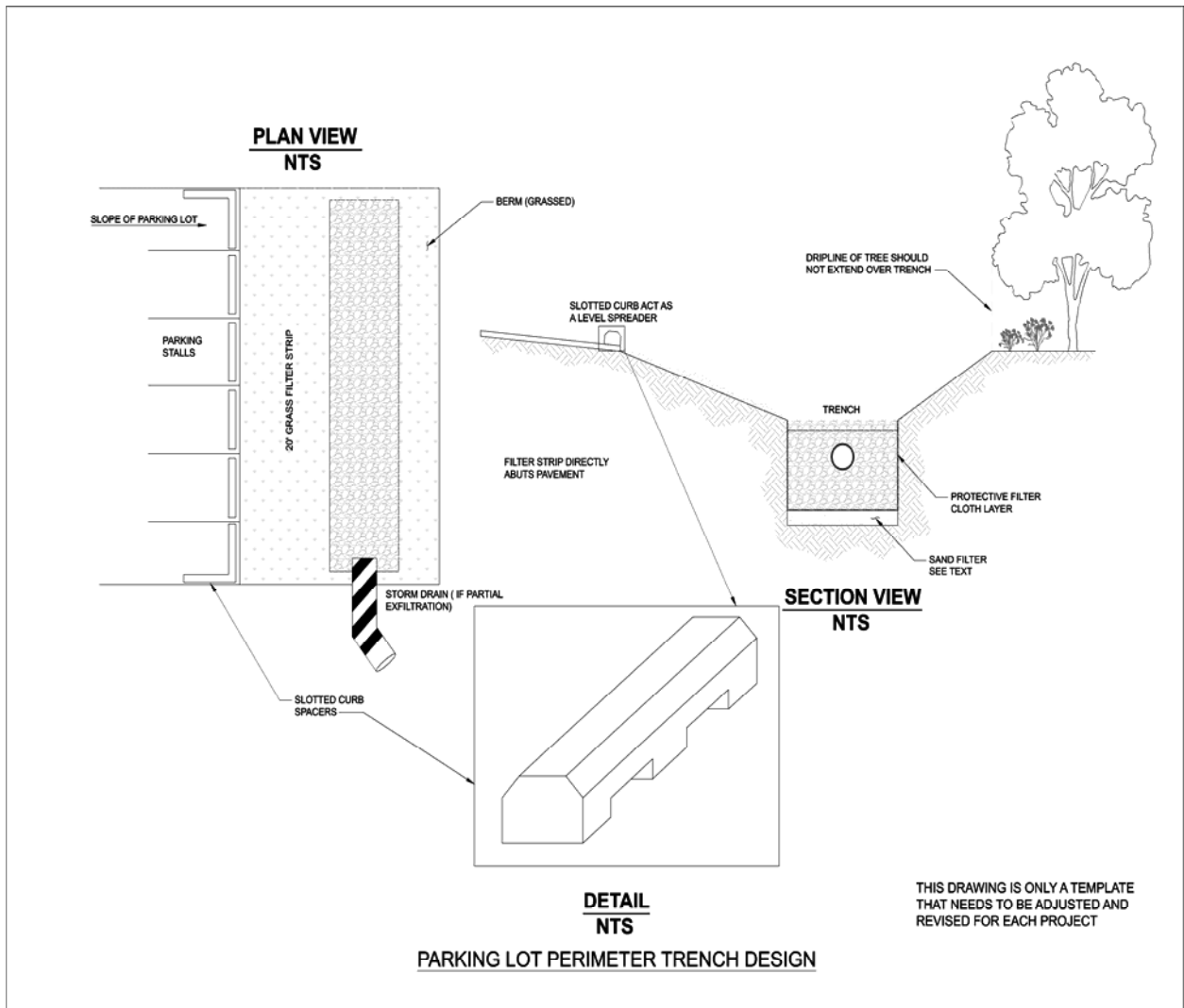

Source: Schueler.

Figure IN.03.1. Parking lot perimeter trench design.

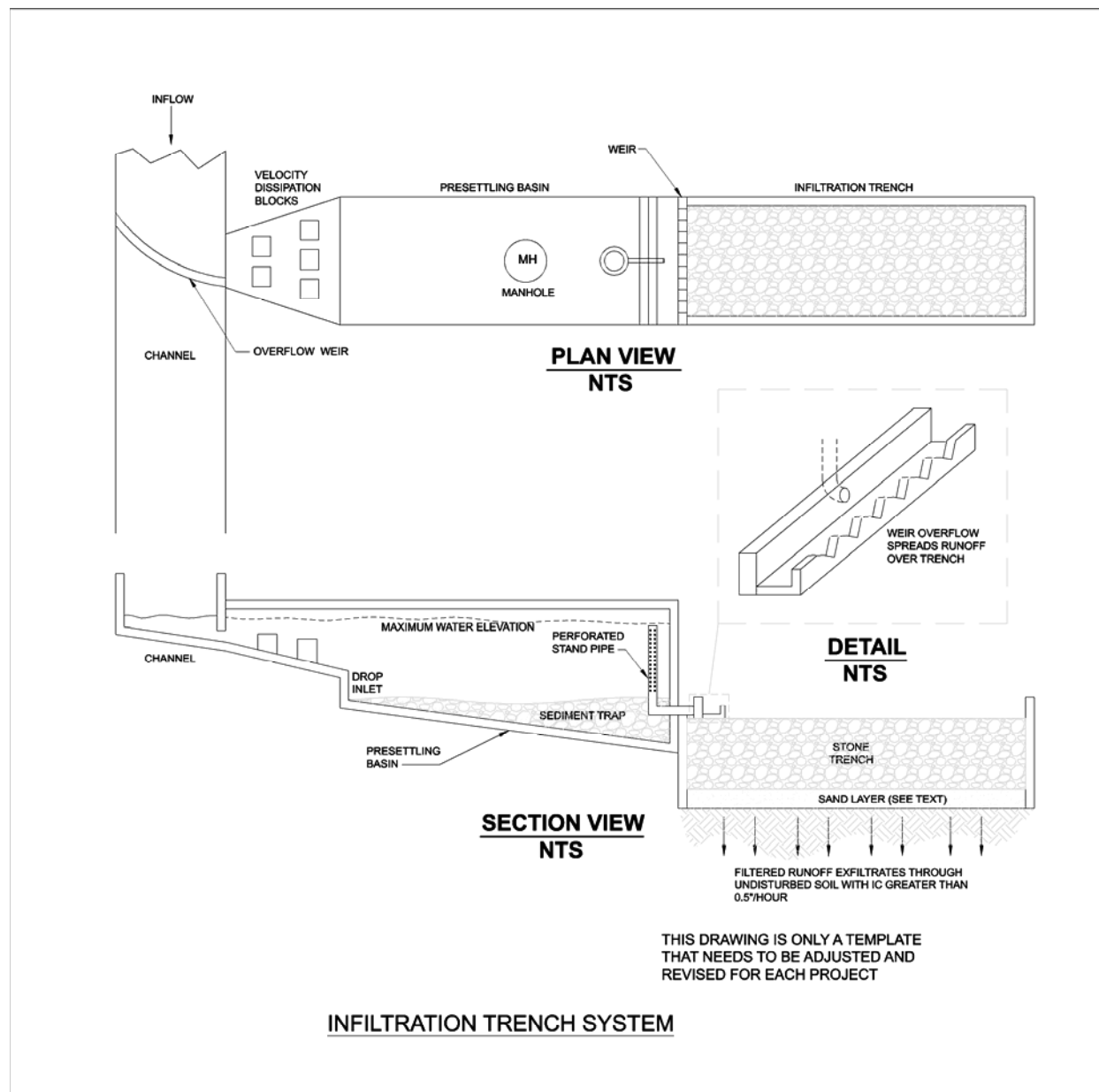

Source: Schueler.

Figure IN.03.2. Infiltration trench system.

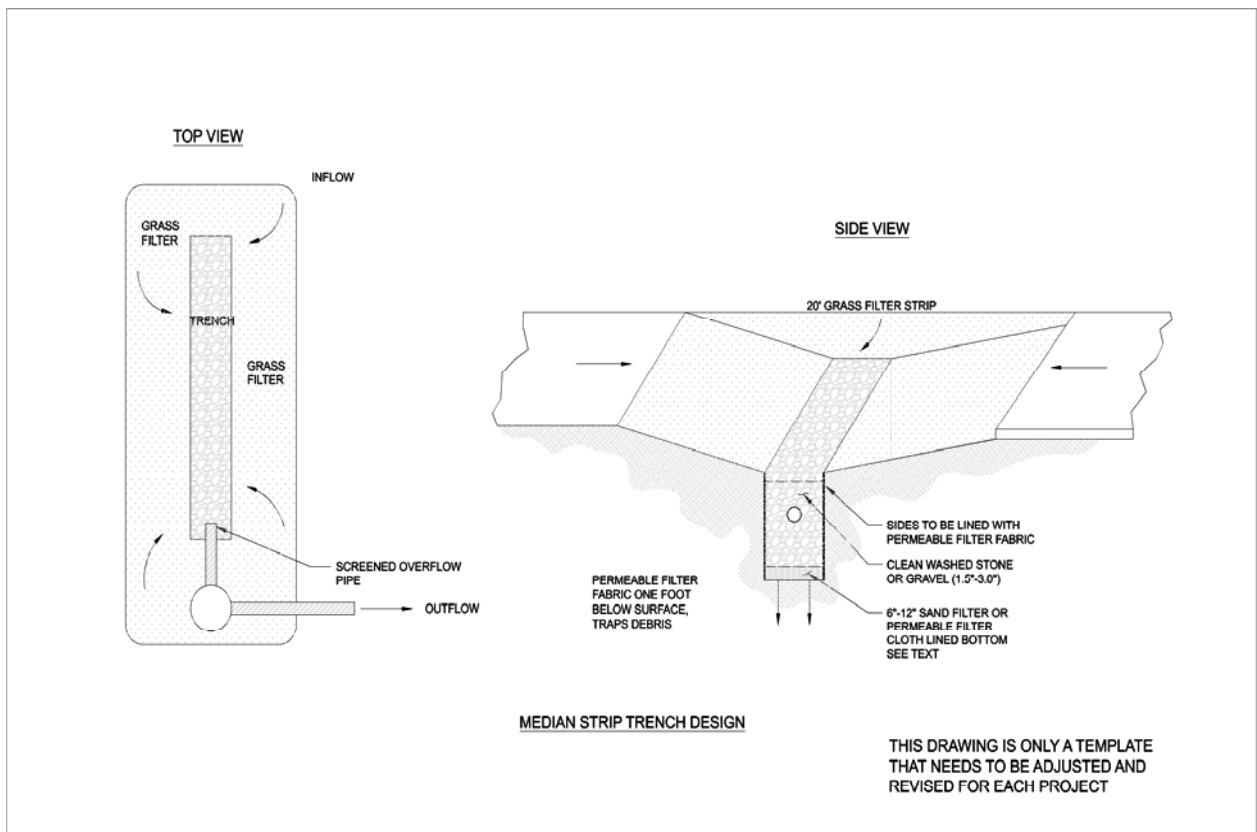

Source: Schueler.

Figure IN.03.3. Median strip trench design.

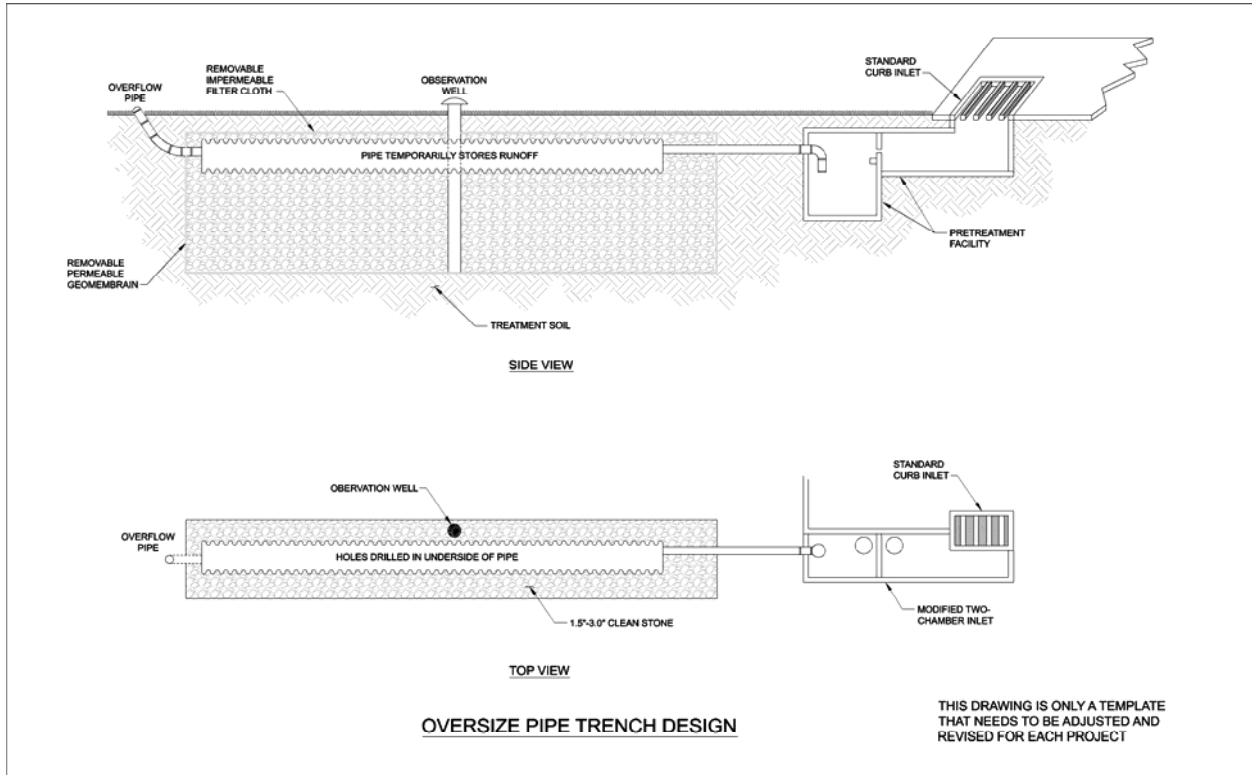

Source: Schueler.

Figure IN.03.4. Oversize pipe trench design.

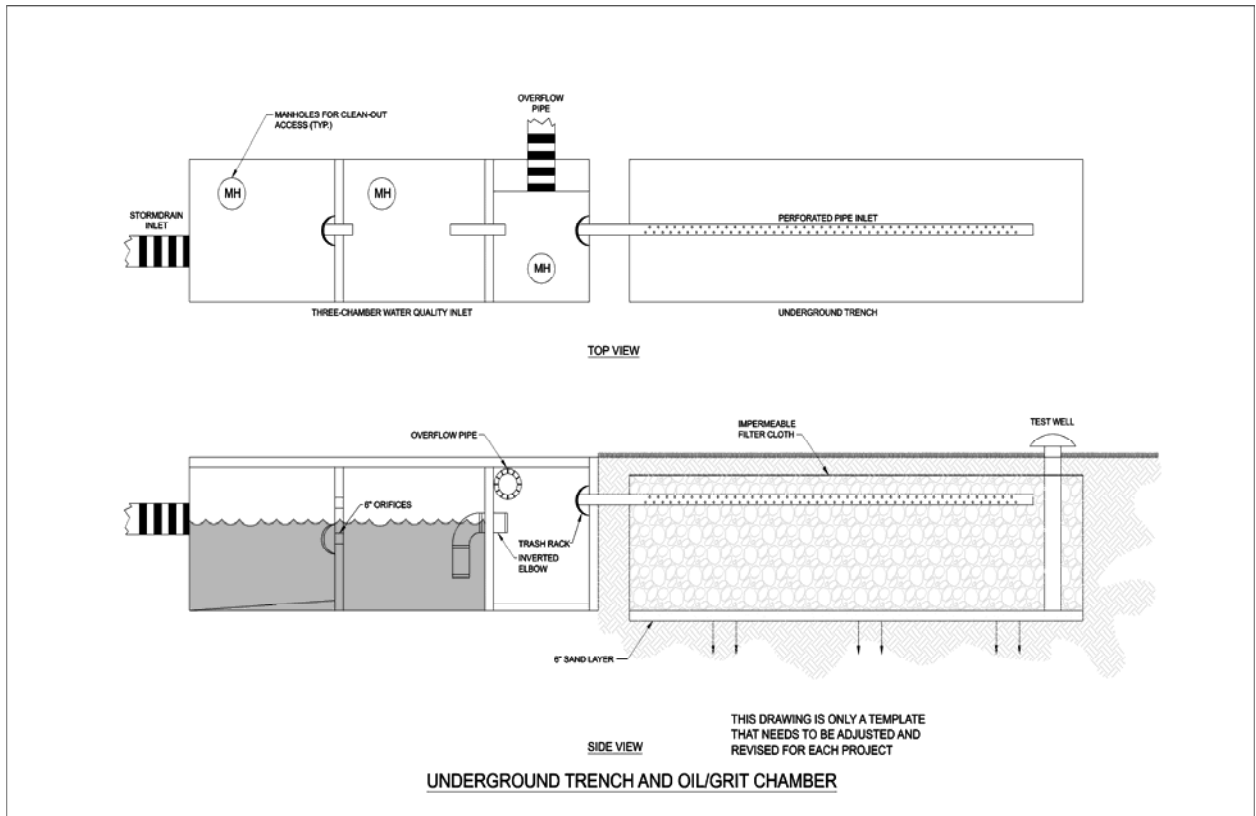

Source: Schueler.

Figure IN.03.5. Underground trench and oil/grit chamber.

Design Flow Elements

Flows to Be Infiltrated

The flows to be treated by an infiltration trench are identical to those for BMP IN.02, Infiltration Pond. (See Section 4-5.4.1, Design Procedure for Infiltration Trenches, for flow control criteria.)

Overflow or Bypass

Because infiltration trenches are generally used for small drainage areas, an emergency spillway is not necessary. However, a nonerosive overflow channel leading to a stabilized watercourse should be provided.

Outlet Control Structure

Outlet control structure requirements for an infiltration trench are identical to those for BMP IN.02, Infiltration Pond.

Flow Splitters

Flow splitter requirements for an infiltration trench are identical to those for BMP IN.02, Infiltration Pond.

Structural Design Considerations

Geometry

Infiltration trench sizing methods are the same as those for BMP IN.02, Infiltration Pond.

Materials

Backfill Material

The backfill material for the infiltration trench should consist of clean aggregate with a maximum diameter of 3 inches and a minimum diameter of 1.5 inches. Void space for the aggregate should be in the range of 30% to 40%.

Geotextile Fabric Liner

An engineering geotextile material must encase all of the aggregate fill material, except for the top 1 foot of the trench where an aggregate surface is the final ground condition. Geotextile fabric with acceptable properties must be carefully selected to avoid plugging. (See geotextile for underground drainage in Section 9-33 of the *Standard Specifications*.) The bottom sand or geotextile fabric shown in Figures IN.03.1 through IN.03.3 is optional.

Refer to Section 5-6, References, for publications by the Federal Highway Administration (FHWA) (1995) regarding design criteria on geotextiles in drainage applications. Also, see the National Cooperative Highway Research Program (NCHRP) (1994) for long-term

performance data and background on the potential for geotextiles to clog or blind and for piping to be incorporated and how to design for these issues.

Observation Well

An observation well should be installed at the lower end of the infiltration trench to check water levels, drawdown time, and sediment accumulation, and to allow for water quality monitoring. The well should consist of a perforated PVC pipe 4 to 6 inches in diameter, constructed flush with the ground elevation. For larger trenches, a 12- to 36-inch-diameter well can be installed to facilitate maintenance operations such as pumping out trapped sediment. The top of the well should be capped to discourage vandalism and tampering. (See Figure IN.03.6 for more details.)

Groundwater Issues

Groundwater issues for an infiltration trench are identical to those for BMP IN.02, Infiltration Pond.

Site Design Elements

Setback Requirements

Setback requirements for an infiltration trench are identical to those for BMP IN.02, Infiltration Pond.

Landscaping (Planting Considerations)

The trench bottom and sides should be stabilized with a mixture of native grasses that will also enhance water quality. The landscape architect will specify plant material.

Maintenance Access Roads (Access Requirements)

Because of accessibility and maintenance limitations, infiltration trenches must be carefully designed and constructed. The local jurisdiction should be contacted for additional specifications.

An access port or an open or grated top should be considered to permit access for inspections and maintenance.

Construction Criteria

Trench Preparation

Excavated materials must be placed away from the trench sides to enhance trench wall stability. Care should be taken to keep this material away from slopes, neighboring property, sidewalks, and streets. It is recommended that this material be covered with plastic.

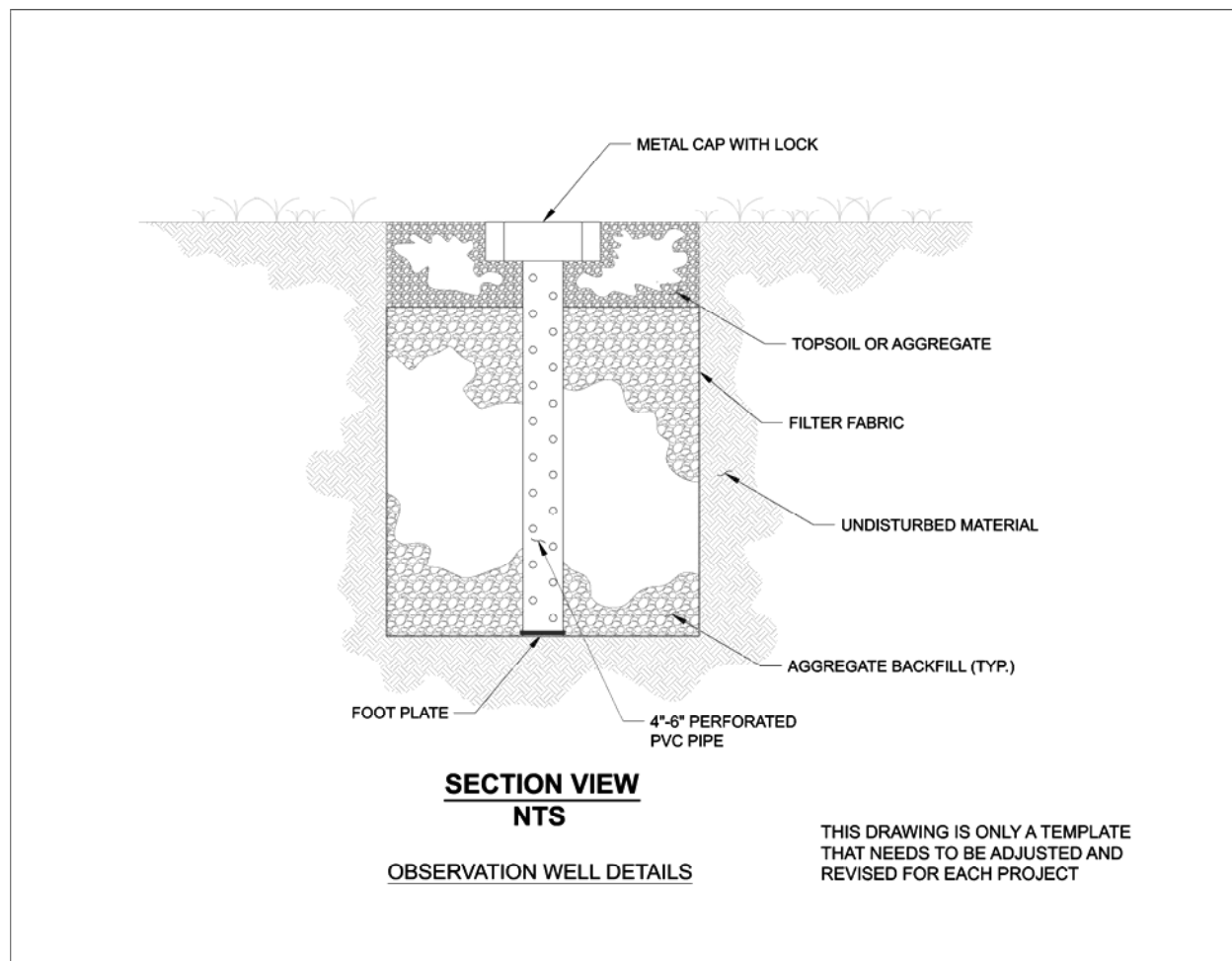

Source: King County.

Figure IN.03.6. Observation well detail.

Stone Aggregate Placement and Compaction

The stone aggregate should be placed in lifts and compacted using plate compactors. As a rule of thumb, a maximum loose lift thickness of 12 inches is recommended. The compaction process ensures geotextile conformity to the excavation sides, thereby reducing potential piping and geotextile clogging, as well as settlement problems.

Separation of Aggregate from Surrounding Soil

Natural or fill soils must not intermix with the stone aggregate. If the stone aggregate becomes mixed with the soil, the stone aggregate must be removed and replaced with uncontaminated stone aggregate.

Overlapping and Covering

Following the stone aggregate placement and compaction, the geotextile must be folded over the stone aggregate to form a 12-inch-minimum longitudinal overlap. When overlaps are required between rolls, the upstream roll should overlap a minimum of 2 feet over the downstream roll to provide a shingled effect.

Voids Behind Geotextile

Voids between the geotextile and excavation sides must be avoided. The space left by boulders or other obstacles removed from the trench walls is one source of such voids. Natural soils should be placed in these voids at the most convenient time during construction to ensure geotextile conformity to the excavation sides. Soil piping, geotextile clogging, and possible surface subsidence can be avoided by this remedial process.

Unstable Excavation Sites

Vertically excavated walls may be difficult to maintain in areas where the soil moisture is high or where soft or cohesionless soils predominate. Trapezoidal, rather than rectangular, cross sections may be needed.

Initial excavation should be conducted to within 1 foot of the final elevation of the infiltration pond floor. Final excavation to the finished grade should be deferred until all disturbed areas in the upgradient drainage area have been stabilized or protected. The final phase of excavation should remove all accumulated sediment.

Infiltration trenches, as with all types of infiltration facilities, should generally not be used as temporary sediment traps during construction. If an infiltration trench is to be used as a sediment trap, it must not be excavated to final grade until after the upgradient drainage area has been stabilized. Any accumulation of silt in the trench must be removed before the trench is put into service.

Operation and Maintenance

Infiltration trenches, as with all BMPs, must have routine inspection and maintenance designed into the life performance of the facility. (See Section 5-5 for more details.)

IN.04 – Infiltration Vault

Introduction

General Description

Infiltration vaults are typically bottomless underground structures used for temporary storage and infiltration of stormwater runoff to groundwater. Infiltration tanks are large-diameter cylindrical structures with perforations in the base. These types of underground infiltration facilities can be a useful alternative for sites with constraints that make siting an infiltration pond difficult. They may also be modified for runoff treatment (see Section 4-5.1).

Applications and Limitations

Infiltration of runoff is the preferred method of flow control following appropriate runoff treatment. Runoff in excess of the infiltration capacity must be detained and released in compliance with the flow control requirement described in Section 3.3.6 under Minimum Requirement 6.

Site Suitability Criteria

Site suitability criteria are the same as for infiltration ponds (see BMP IN.02).

Infiltration vaults are not allowed on slopes greater than 25% (4H:1V). On slopes over 15%, a geotechnical report may be required for evaluation by a professional engineer with geotechnical expertise or a qualified geologist with jurisdiction approval. A geotechnical report may also be required if the proposed vault is located within 200 feet of the top of a steep slope or landslide hazard area.

Presettling/Pretreatment

Infiltration vaults should follow a runoff treatment or pretreatment facility to prevent sediment accumulation and clogging of the basin. (See Section 5-4.3.1 for pretreatment design criteria.)

Design Flow Elements

Flows to Be Infiltrated

The flows to be disposed to groundwater by infiltration vaults are the same as those for infiltration ponds (see BMP IN.02).

Overflow or Bypass

A primary overflow must be provided to bypass flows over the 100-year postdeveloped peak flow to the infiltration vault. (See BMP FC.03, Detention Pond, for overflow structure types.)

Outlet Control Structure

Outlet control structure requirements for infiltration vaults are the same as those for infiltration ponds (see BMP IN.02).

Flow Splitters

Flow splitter requirements for infiltration vaults are the same as those for infiltration ponds (see BMP IN.02).

Structural Design Considerations

Geometry

Infiltration vault geometric design criteria are the same as those for infiltration ponds (see BMP IN.02).

Note: If a vault is over 20 feet in width it must be designed by the HQ Bridge and Structures Office and added to the bridge inspection inventory by the Preservation Section.

Materials

All vaults must meet structural requirements for overburden support and H-20 vehicle loading. Vaults located under roadways must meet the live load requirements of the *Standard Specifications*. Cast-in-place wall sections must be designed as retaining walls. Structural designs for cast-in-place vaults must be stamped by a licensed structural civil engineer. Bottomless vaults must be provided with footings placed on stable, well-consolidated native material and sized considering overburden support, traffic loading (assume maintenance traffic, if vault is placed outside right of way), and lateral soil pressures when the vault is dry. Infiltration vaults are not allowed in fill slopes unless a geotechnical analysis approves fill stability. The infiltration medium at the bottom of the vault must be native soil.

Infiltration vaults may be constructed using material other than reinforced concrete, such as large, perforated, corrugated metal pipe (see Figure IN.04.1), provided that the following additional criteria are met:

- Bedding and backfill material for the structure must be washed drain rock extending at least 1 foot below the bottom of the structure, at least 2 feet beyond the sides, and up to the top of the structure.

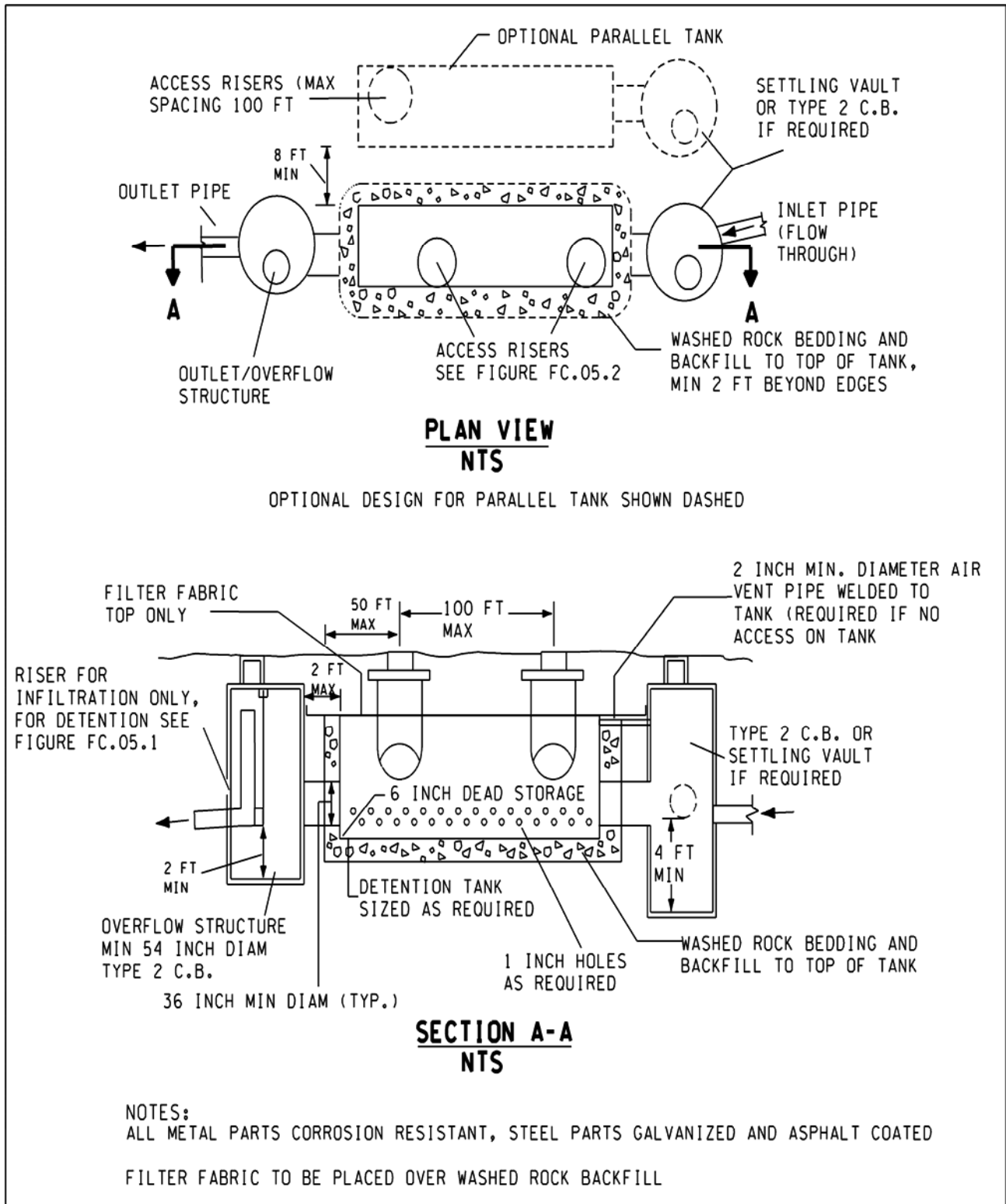

Figure IN.04.1. Infiltration vault constructed with corrugated pipe.

- Drain rock must be completely covered with construction geotextile for separation (per the *Standard Specifications*) prior to backfilling. If the drain rock becomes mixed with soil, the affected rock material must be removed and replaced with washed drain rock to provide maximum infiltration effectiveness.
- The perforations (holes) in the bottom half of the pipe must be 1 inch in diameter and start at an elevation of 6 inches above the invert. The nonperforated portion of the pipe in the lower 6 inches is intended for sediment storage to protect clogging of the native soil beneath the structure. The number and spacing of the perforations should be sufficient to allow complete infiltration of the soils with a safety factor of 2.0 without jeopardizing the structural integrity of the pipe.
- The criteria for general design, materials, structural stability, buoyancy, maintenance access, access roads, and right of way are the same as those for detention tanks (see BMP FC.03), except for features needed to facilitate infiltration.

Groundwater Issues

Groundwater issues for infiltration vaults are the same as those for infiltration ponds (see BMP IN.02).

Maintenance Access Roads (Access Requirements)

For general maintenance requirements, see Section 5-3.6.1.

Construction Criteria

Initial excavation should be conducted to within 1 foot of the final elevation of the infiltration vault base. Final excavation to the finished grade should be deferred until all disturbed areas in the upgradient drainage area have been stabilized or protected. The final phase of excavation should remove all accumulated sediment.

Infiltration vaults, as with all types of infiltration facilities, should generally not be used as temporary sediment traps during construction. If an infiltration vault is to be used as a sediment trap, it must not be excavated to final grade until after the upgradient drainage area has been stabilized. Any accumulation of silt in the vault must be removed before the vault is put into service.

Relatively light-tracked equipment is recommended for excavation to avoid compacting the soil beneath the base of the infiltration vault. The use of draglines and trackhoes should be considered. The infiltration area should be flagged or marked to keep equipment away.

Operation and Maintenance

Infiltration vaults, as with all BMPs, must have routine inspection and maintenance designed into the life performance of the facility. (See Section 5-5 for more details.)

IN.05 – Drywell

Introduction

General Description

Drywells are subsurface concrete structures, typically precast, that convey stormwater runoff into the soil matrix. They can be used as stand-alone structures or as part of a larger drainage system (for example, the overflow for a bioinfiltration pond).

Applications and Limitations

Drywells may be used for flow control where runoff treatment is not required, for flows greater than the runoff treatment design storm, or where runoff is treated before it is discharged. (See Tables 4-13 and 4-14 in Section 4-5.4 for determining when treatment is required prior to infiltration.)

This BMP is considered a subsurface infiltration facility and its use would be subject to the rules governing Class V underground injection wells. This type of stormwater facility must be registered through Ecology's UIC (Underground Injection Control) Program. For more information on UIC requirements, see Section 4-5.4.

Uncontaminated or properly treated stormwater must be discharged to drywells in accordance with Ecology's UIC Program (WAC 173-218).

Presetting/Pretreatment

Treatment for removal of total suspended solids (TSS), oil, and soluble pollutants may be necessary before the stormwater is conveyed to a drywell. Companion practices, such as street sweeping and catch basin inserts, can provide additional benefits and reduce the cleaning and maintenance needs for the infiltration facility.

Design Flow Elements

Inflow to infiltration facilities is calculated according to the methods described in Chapter 4. The storage volume in the detention facility above the drywell is used to detain runoff prior to infiltration. The infiltration rate is used in conjunction with the size of the storage area to design the facility. To prevent the onset of anaerobic conditions, the infiltration facility must be designed to drain completely 72 hours after the flow to it has stopped.

In general, an infiltration facility should have two discharge modes. The primary mode of discharge is infiltration into the ground. However, when the infiltration capacity of the facility is reached, a secondary discharge mode is needed to prevent overflow. Overflows from an infiltration facility must comply with Minimum Requirement 6 in Section 3-3.6.

Flows to Be Infiltrated

The flows to be disposed to groundwater by drywells are the same as those for infiltration ponds (see BMP IN.02).

Overflow or Bypass

A primary overflow must be provided to bypass the 100-year postdeveloped peak flow over or around the flow restrictor system.

Structural Design Considerations

Geometry

The *Standard Plans* show typical details for drywell systems. These systems are designed as specified below.

- Drywell bottoms should be a minimum of 5 feet above seasonal high ground-water level or impermeable soil layers. Refer to the *Setback Requirements* below.
- Typically, drywells are 48 inches (minimum) in diameter and are approximately 5 to 10 feet (or more) deep.
- Filter fabric (geotextile) may need to be placed on top of the drain rock and on trench or drywell sides before the drywell is backfilled to prevent migration of fines into the drain rock, depending on local soil conditions and local jurisdiction requirements.
- Drywells should be spaced no closer than 30 feet center to center or twice the structure depth in free-flowing soils, whichever is greater.
- Drywells should not be built on slopes greater than 25% (4H:1V).
- Drywells may not be placed on or above a landslide hazard area or slopes greater than 15% without evaluation by a professional engineer with geotechnical expertise, or a qualified geologist, and approval by the local jurisdiction.

Groundwater Issues

A site is not suitable if the infiltration of stormwater may cause a violation of Ecology ground-water quality standards. Local jurisdictions should be consulted for applicable pollutant removal requirements upstream of the infiltration facility and to determine whether the site is located in an aquifer-sensitive area, sole-source aquifer, or a wellhead protection zone.

A drywell may be considered for runoff collection from those areas requiring oil control (see Table 3-1). For such applications, sufficient pollutant removal, including oil removal, must be provided upstream of the infiltration facility to prevent violations of groundwater quality standards and adverse effects on the infiltration facility.

Vadose Zone Requirements

As mentioned under *Geometry*, the base of all infiltration systems should be at least 5 feet above the seasonal high-water level, bedrock (or hardpan), or other low-permeability layer.

The base of the facility may be within 3 feet if the groundwater mounding analysis, volumetric receptor capacity, and design of the overflow or bypass structures are judged by the designer to be adequate to prevent overtopping and meet the site suitability criteria.

The designer should investigate whether the soil under the proposed infiltration facility contains contaminants that could be transported by infiltration from the facility. If so, measures should be taken for remediation of the site before the facility is constructed or an alternative location should be chosen. The designer should also determine whether the soil beneath the proposed infiltration facility is unstable due to improper placement of fill, subsurface geologic features, or other reasons. If so, further investigation and planning should be undertaken before siting the facility.

Site Design Elements

Setback Requirements

Setback requirements for drywells are the same as those for infiltration ponds (see BMP IN.02).

Signage

Requirements for signs are the same as those for detention ponds (see BMP FC.03).

IN.06 – Permeable Pavement Surfaces**Introduction*****General Description***

Currently, this BMP cannot be considered a stand-alone runoff treatment or flow control BMP. However, when used as part of a project surface, it can reduce the total runoff, thereby providing an overall reduction to the size and placement of other acceptable runoff treatment and flow control BMPs.

Permeable (porous or pervious) *surfaces* can be applied to non-pollution-generating surfaces such as pedestrian/bike paths, raised traffic islands, and sidewalks. Permeable surfaces with a media filtration sublayer (such as sand or an amended soil) could be applied to pollution-generating surfaces (such as parking lots) for calculating runoff treatment. Permeable surfaces allow stormwater to pass through and infiltrate the soil below, thereby reducing the rate and volume of runoff associated with conventional surfacing and fostering groundwater recharge.

The permeable concrete or asphalt pavement surface is an open-graded mix placed in a manner that results in a high degree of interstitial spaces or voids within the cemented aggregate. This technique demonstrates a high degree of absorption or storage within the voids and infiltration to subsoils. The pavement may be permeable concrete, permeable asphalt, or manufactured systems such as interlocking brick or a combination of sand and brick lattice. Geo-Cell with geotextile and aggregate material may also be considered for limited applications.

Applications and Limitations

Applications

WSDOT is taking a responsible approach toward applying permeable surface systems within projects. Possible areas for use of these permeable surface materials include the following:

- Sidewalks, bicycle trails, community trail/pedestrian path systems, or any pedestrian-accessible paved areas (such as traffic islands)
- Vehicle access areas, including emergency stopping lanes, maintenance/enforcement areas on divided highways, and facility maintenance access roads
- Public and municipal parking lots, including perimeter and overflow parking areas

Permeable surface systems function as stormwater infiltration areas and temporary stormwater retention areas that can accommodate pedestrians and light- to medium-load parking areas. They are applicable to both residential and commercial applications, with the exception of heavy truck traffic. This combination of functions offers the following benefits:

- Captures and retains precipitation on-site
- Mimics natural soils filtration throughout the pavement depth, underlying sub-base reservoir, and native soils for improved groundwater quality
- Eliminates surface runoff, depending on existing soil conditions
- Greatly reduces or eliminates the need for an on-site stormwater management system
- Reduces drainage water runoff temperatures
- Increases recharge of groundwater
- Provides runoff treatment with a media filtration layer
- Thaws quicker when covered by ice or snow

Handling and placement practices for permeable surfaces are different from conventional pavement placement. Unlike conventional pavement construction, it is important that the underlying native or subgrade soils be nominally consolidated to prevent settling and minimize the effect of intentional or inadvertent heavy compaction due to heavy equipment operation during construction. Consolidation can be accomplished using static dual-wheel small mechanical rollers or plate vibration machines. If heavy compaction does occur, then tilling may be necessary to a depth of 2 feet below the material placement. This would occur prior to subsequent application of the separation and base layers.

Contractors shall have prior experience with constructing permeable surfaces. If a contractor does not have this experience, the contractor shall be required to construct test panels before placement of the main surfacing to demonstrate application competency.

Permeable surfaces are vulnerable to clogging from sediment in runoff. The following techniques will reduce this potential:

- **Surface runoff.** Permeable surfaces should not be located where turbid runoff from adjacent areas can introduce sediments onto the permeable surface. Designs should slope impervious runoff away from permeable pavement installations to the maximum extent possible.
- **Diversion.** French drains, or other diversion structures, may be designed into the system to avoid unintended off-site runoff. Permeable systems can be separated using edge drain systems, turnpikes, and 0.15-foot-high tapered bumps.
- **Cold climates.** Snow removal activities (plowing) and the use of salt and abrasives can increase the risk of clogging.
- **Slopes.** Off-site drainage slopes immediately adjacent to the permeable surface should be less than 5% to reduce the chance of soil loss that would cause clogging.

Limitations

Suitable grades, subsoil drainage characteristics, and groundwater table conditions require good multidisciplinary analysis and design. Proper construction techniques and diligent field inspection during the placement of permeable surfaces are also essential to a successful installation.

- Installation works best with level, adjacent slopes—1% to 2%—and on upland soils. Permeable surface installations are not appropriate when adjacent draining slopes are 5% or greater.
- An extended period of saturation of the base material underlying the surface is undesirable. Therefore, the subsurface reservoir layer should fully drain in a period of less than 36 hours.
- The minimum depth from the bottom of the base course to bedrock and seasonally high water table should be 3 feet, unless it is possible to engineer a groundwater bypass into the system.
- Sanding or repeated snow removal can lead to a reduction in surface permeability. Permeable surfaces should not be used in traffic areas where sanding or extensive snow removal is carried out in the winter.

Examples of situations where the use of permeable surfaces is not currently recommended include the following:

- Roadway lanes because of a number of considerations (such as dynamic loading, safety, clogging, and heavy loads). More study and experience are needed before using permeable surfaces in these situations. Use of any type of shoulder application whereby the retained moisture drains away from the

main line requires coordinated approval from materials, roadway design, hydraulics, and maintenance support staff.

- Areas where the permeable surface will be routinely exposed to heavy sediment loading.
- Areas such as maintenance yards that are subject, or potentially subject, to higher pollutant loadings, spills, and piles of bulk materials (such as sand or salt) should not incorporate permeable pavements.
- Areas where the risk of groundwater contamination from organic compounds is high (for example, fueling stations, commercial truck parking areas, and maintenance and storage yards).
- Within 100 feet of a drinking water well and within areas designated as sole-source aquifers.
- Areas with a high water table or impermeable soil layer as defined in Section 4-5, Infiltration Design Criteria.
- Within 100 feet upgradient or 10 feet downgradient from building foundations. Closer upgradient distances may be considered where the minimum seasonal depth to groundwater lies below the foundation or where it can be demonstrated that infiltrating water from the permeable surface will not affect the foundation.

General Design Criteria

All projects considering the use of permeable surfaces should be further explored in coordination with the HQ Design, Materials Lab, Hydraulics, and Maintenance offices.

- As long as runoff is not directed to the permeable asphalt from adjacent surfaces, the estimated long-term infiltration rate may be as low as 0.1 inch/hour. Soils with lower infiltration rates should have underdrains to prevent prolonged saturated soil conditions at or near the ground surface within the pavement section (PSAT, 2005).
- For initial planning purposes, permeable surface systems will work well on Hydrologic Soil Groups A and B and can be considered for Group C soils. Standard three-layer placement sections for Group D soils may not be applicable.
- For projects constructed upon Group C and D soils, a minimum of three soil gradation analyses or three infiltration tests should be conducted to establish on-site soil permeability. Otherwise, a minimum of one such test should be conducted for Group A and B soils to verify adequate permeability.
- Ideally, the base layer should be designed with sufficient depth to meet flow control requirements (taking into account infiltration). If the infiltration rate and base layer's recharge bed storage does not meet flow control requirements, an underdrain system may be required. The underdrain could

be discharged to a bioretention area, dispersion system, or stormwater detention facility.

- Turbid runoff to the permeable surface from off-site areas is not allowed. Designs may incorporate infiltration trenches or other options to ensure long-term infiltration through the permeable surface.
- Any necessary boreholes must be installed to a depth of 10 feet below the base of the reservoir layer, and the water table must be monitored at least monthly for a year.
- Infiltration systems perform best on upland soils.

On-site soils should be tested for porosity, permeability, organic content, and potential for cation exchange. These properties should be reviewed when designing the recharge bed of pervious surfaces.

Once a permeable surface site is identified, contact the WSDOT Materials Lab to request that a geotechnical investigation be performed. The WSDOT Materials Lab, with assistance (as needed) from the HQ Geotechnical Services Division, will determine the quantity and depth of borings/test pits required and any groundwater monitoring needed to characterize the soil infiltration characteristics of the site. Table IN.06.1 provides general guidelines on the overall composition of permeable surfaces based on various soil conditions.

On site locations where subgrade materials are marginal, the use of a heavy-duty geogrid placed directly on subgrade may be necessary. A sand layer is placed above the heavy geogrid, followed by geotextile for drainage. Coordination with the HQ Geotechnical Services Division should be made for these applications.

For determining a final design-level infiltration rate, refer to the design criteria provided in Section 4-5. Note: These criteria apply primarily to infiltration basins and may therefore exclude slower-percolating soils such as loams, which are potentially suitable for permeable surfaces.

Flow control modeling guidance for permeable pavements can be found in Table 4-3 of Chapter 4.

Table IN.06.1. Permeable surface application matrix.

Soil Characterization Chart for Design of Permeable Surface Layers					
Soil Type ^(a)	A	B	C	D	Notes
Surface Layer	1 – 4 ^(b)	1 – 4 ^(b)	1 – 4 ^(b)	1 – 4 ^(b)	4-inch depth (min.).
Base Layer	5	5	5	5	6-inch depth (min.). Aggregate base depths of 18 to 36 inches are common depending on storage needs (PSAT, 2005).
Separation Layer	7	7	7	7	The separation layer provides a permeable barrier to prevent fine soil particles from migrating up into the base aggregate.
Water Quality Treatment Layer	Not Required ^(c)	Not Required ^(c)	6 or 8	6 or 8	The treatment media can consist of a sand layer or an engineered amended soil (PSAT, 2005).
Subgrade Soil	9	9	9	9	If subgrade is overly compacted prior to constructing pavement, till soil 2 feet below the material placement to maintain the soil’s permeability.
Underdrain System	No	No	To be determined	To be determined	6-inch-diameter (min.): discharged to bioretention area, natural dispersion, or a detention facility.
Edge Treatment	To be considered	To be considered	To be considered	To be considered	6-inch-diameter (min.): discharged to bioretention area, natural dispersion, or a detention facility.
Subgrade Slope	To be considered	To be considered	To be considered	To be considered	Consider slopes from 1.0% to 2.0%.
Placement Application	10 – 15	10 – 15	10 – 15	11 – 15	

- Surface Type**
 - 1 Portland Cement-Based Pervious Pavement Materials
 - 2 Asphalt-Based Pervious Pavement Materials
 - 3 Paving or Lattice Stone
 - 4 Geo-Cell
 - Base Type**
 - 5 BARB (Base Aggregate for Recharge Bed) ^(d)
 - Separation**
 - 6 Sand
 - 7 Geotextile ^(e)
 - 8 Engineered Amended Soil
 - Miscellaneous Placements**
 - 9 Minimum Consolidation Required
 - 10 Residential or Access Driveways
 - 11 Sidewalks
 - 12 Bike Paths
 - 13 Traffic Islands
 - 14 Median Turn-Around
 - 15 Parking Lots
- ^(a) See Table 4B.1 in Appendix 4B for Soil Types.
- ^(b) The separation of permeable surface installations from impermeable surface runoff may be necessary by installing an edge drain or a similar system.
- ^(c) A treatment layer is not required where the subgrade soil has a long-term infiltration rate < 2.4 inches/hour and a cation exchange capacity greater than or equal to 5-milliequivalents/100 grams of dry soil.
- ^(d) Variances other than that specified in the special provision, Base Aggregate for Recharge Bed, should be reviewed and included as applicable and coordinated with the WSDOT Materials Lab, HQ Design Office, and HQ Hydraulics Section.
- ^(e) Permeable geotextile must be used to keep the surface layer stable and fines from migrating up through base and surface layers. To obtain geotextile classification, use Geotextile for Underground Drainage, Standard Specification, Section 9-33, as specified in the Special Provision, Base Aggregate for Recharge Bed, and the *Design Manual*.

Design Flow Elements

Flows to Be Infiltrated

The design criteria below assume that it is feasible to meet the flow control requirements by sizing a storage volume within the subsurface layers. This needs to be explored further for viability. It is possible that the design criteria for an infiltration trench may be more comprehensive and applicable than the general guidelines provided below. There has been discussion in the past that using permeable pavement surfaces is a part of low-impact development (LID) practices and would only result in some form of credit being applied to flow control mitigation.

For western Washington, use an acceptable continuous runoff simulation model to size an infiltration basin, as described in Section 4-5, Infiltration Design Guidelines. Modeling guidelines can be derived from Section 4-3.6.1, Continuous Simulation Method. For eastern Washington, use an appropriate single-event-based model consistent with Section 4-5 guidelines. For sizing purposes, use the following guidelines:

- The bottom area of an “infiltration basin” will typically be equivalent to the area below the surrounding grade underlying the permeable surface. Adjust the depth of this “infiltration basin” so that it is sufficient to store the required design volume.
- Multiply this depth by a factor of 5. This will determine the depth of the gravel base underlying the permeable surface. This assumes a void ratio of 0.20—a conservative assumption. When a base material that has a different porosity will be used, that value may be substituted to determine the depth of the base. The minimum base depth is 6 inches, which allows for adequate structural support of the permeable surface.
- For a large, contiguous area of permeable surface, such as a parking lot, the area may be designed with a level surface grade and a sloped subgrade to prevent water buildup on the surface, except under extreme conditions. Rare instances of shallow ponding in a parking lot are normally acceptable.
- For projects where ponding is unacceptable under any condition, the surface of the parking lot may be graded at a 1% slope leading to a shallow swale, which would function to ensure emergency drainage (similar to an emergency overflow from a conventional infiltration pond). However, the design depth of the base material must be maintained at all locations.

Facility Design Considerations

Geometry

The Special Provisions referenced below are still under development. Until these provisions have been completed, designers should coordinate directly with the WSDOT Materials Lab for further guidance on project application requirements.

The following Special Provisions for permeable surfaces can be used to assist with final Plans, Specifications, and Estimates (PS&E) development:

- GSP XXX, Subgrade Preparation for Pervious Surfacing
- GSP XXX, Recharge Bed for Pervious Surfacing
- GSP XXX, Pervious Asphalt
- GSP XXX, Pervious Cement Concrete

Maintenance Considerations

Permeable surfaces require more maintenance than conventional pavement installations. The primary concern in maintaining the continued effectiveness of a permeable surface system is to prevent the surface from clogging with fine sediments and debris. (See Section 5-5 for operation and maintenance guidelines.)

Materials

Permeable surfaces consist of a number of components: the surface pavement, an underlying base layer, a separation layer, and the native soil or subgrade soil (see Figure IN.06.1). An overflow or underdrain system may need to be considered as part of the pavement's overall design.

Surface Layer

The surface layer is the first component of a permeable system's design that creates the ability for water to infiltrate through the surface. Permeable paving systems allow infiltration of storm flows; however, the wearing course should not be allowed to become saturated from excessive water volume stored in the aggregate base layer (PSAT, 2005).

Portland Cement-Based Pervious Pavement Materials

The surface layer consists of specially formulated mixtures of Portland cement, uniform open-graded coarse aggregate, and potable water. The depth of the surface layer may increase from a minimum of 4 inches, depending on the required bearing strength and pavement design requirements. The gradation required to obtain a pervious concrete pavement is of the open-graded or coarse type (AASHTO Grading No. 67: $\frac{3}{4}$ inch and lower). For additional information, refer to the pervious pavement specifications.

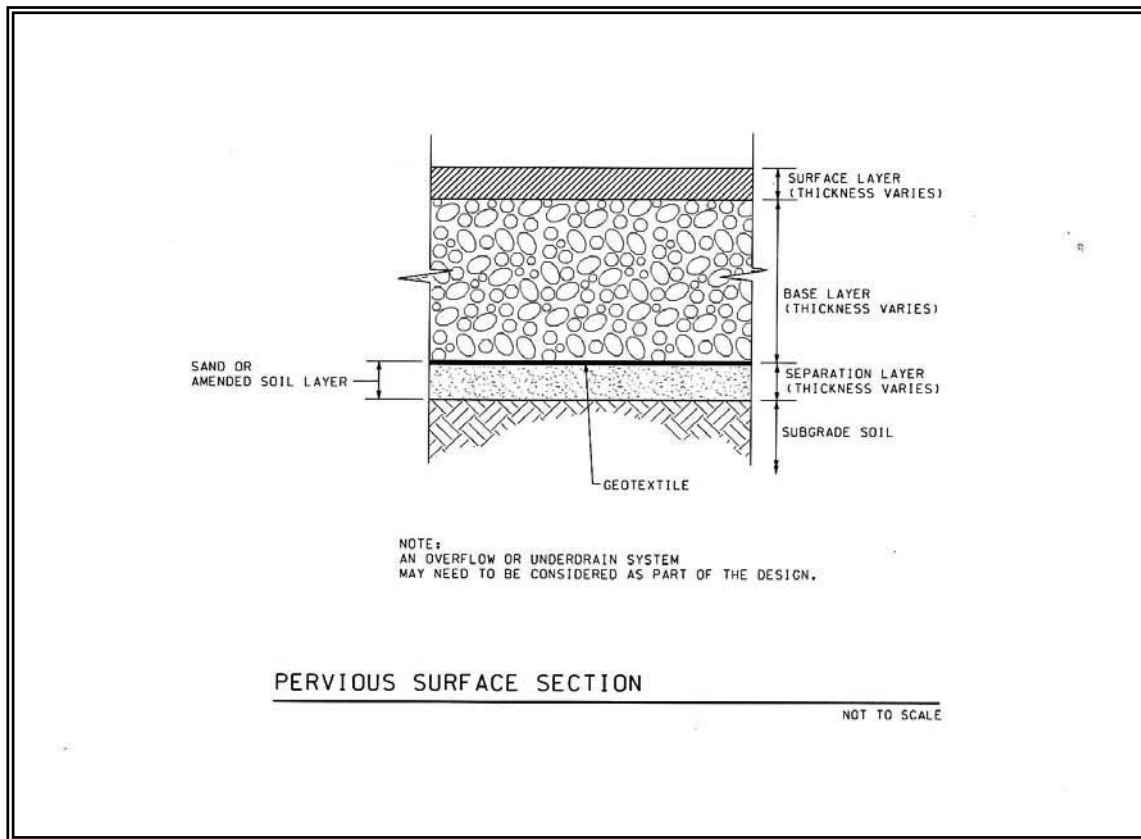

Figure IN.06.1. Permeable pavement surface detail.

Due to the relatively low water content of the concrete mix, an agent may be added to retard concrete setup time. When properly handled and installed, pervious pavement has a higher percentage of void space than conventional pavement (approximately 12% to 21%), which allows rapid percolation of stormwater through the pavement. The initial permeability can commonly exceed 200 inches per hour (Chollack et al., 2001; Mallick et al., 2000).

Asphalt-Based Pervious Pavement Materials

The surface asphalt layer consists of an open-graded asphalt mixture. The depth of the surface layer may increase from a minimum of 4 inches, depending on the required bearing strength and pavement design requirements.

Pervious asphalt pavement consists of an open-graded coarse aggregate. The pervious asphalt creates a surface layer with interconnected voids that provide a high rate of permeability.

Paving and Lattice Stones

Paving and lattice stones consist of a high-compressive-strength stone that may increase from a minimum depth of 4 inches, depending on the required bearing strength and pavement

design requirements. When placed together, these paving stones create a reinforced surface layer. An open-graded fine aggregate fills the voids, which creates a system that provides infiltration into a permeable base layer. This system can be used in parking lots, bike paths, or areas that receive common local traffic.

The Ashway Park and Ride in Marysville utilized paving stones with a peat treatment layer (see photos below).



Geo-Cell (PVC Containment Cell)

A Geo-Cell surface stabilization system consists of a high-strength, UV-resistant, PVC-celled panel that is 4 inches thick. The celled panels can be filled with soil and covered with turf by installing sod. Base gravel may also be used to fill the celled panels. Both applications create a surface layer.

The Geo-Cell creates an interlock layer with interconnected voids that provide a high rate of permeability of water to an infiltrative base layer. The common applications for this system are on slopes and pedestrian/bike paths and in parking and low-traffic areas.

Base Layer

The underlying base material is the second component of a permeable surface's design. The base material is a crushed aggregate and provides the following:

- A stable base for the pavement.
- A high degree of permeability to disperse water downward through the underlying layer to the separation layer.
- A temporary reservoir that slows the migration of water prior to infiltration into the underlying soil.
- Base material is often composed of larger aggregate (1.5 to 2.5 inches) with smaller stone (leveling or choker course) between the larger stone and the wearing course. Typical void space in base layers ranges from 20% to 40% (WSDOT, 2003; Cahill, Adams, and Marm, 2003).
- Depending on the target flow control standard and physical setting, retention or detention requirements can be partially or entirely met in the aggregate base (PSAT, 2005).
- Aggregate base depths of 18 to 36 inches are common depending on storage needs, and they provide the additional benefit of increasing the strength of the wearing course by isolating underlying soil movement and imperfections that may be transmitted to the wearing course (Cahill et al., 2003).

Separation Layer

The third component of permeable systems is the separation layer. This layer consists of a non-woven geotextile fabric and possibly a treatment media base material. A geotextile fabric layer is placed between the base material and the native soil to prevent migration of fine soil particles into the base material, followed by a runoff treatment media layer if required.

- For geotextile, see Standard Specification 9-33.

- For separation base material, see the FHWA manual “*Construction of Pavement Subsurface Drainage Systems*” (2002) for aggregate gradation separation base guidance.
- A treatment media layer is not required where subgrade soil is determined to have a long-term infiltration rate less than 2.4 inches per hour and a CEC of the subgrade soil that is at least 5 milliequivalents/100 grams of dry soil or greater (Ecology, 2001).
- If a treatment media layer is used, it must be distributed below the geotextile layer and above the subgrade soil. The media can consist of a sand filter layer or amended soil. Engineered amended soil layers should be a minimum of 18 inches and incorporate compost, sphagnum peat moss, or other organic material to provide a cation exchange capacity of greater than or equal to 5 milliequivalents/100 grams dry soil (Ecology, 2001). Gradations of the treatment media should follow base sizing.

Subgrade Soil

The underlying subgrade soil is the fourth component of pervious pavement. Runoff infiltrates into the soil and moves to the local interflow or groundwater layer. Compaction of the subgrade must be kept to an absolute minimum to ensure the soil maintains a high rate of permeability while maintaining the structural integrity of the pavement.

Liners

The primary purpose of a permeable pavement system is to promote infiltration. An impervious liner will discontinue infiltration; therefore, a flow control credit is not allowed and the surface is modeled as impervious.

Cost

Materials and mixing costs for permeable asphalt are similar to conventional asphalt. However, when contractors are unfamiliar with permeable asphalt installation and additional costs for handling and installation should be anticipated. Estimates for porous pavement material and installation are approximately \$.60 to \$.70/square foot and will likely be comparable to standard pavement as more contractors become familiar with the product. Due to the lack of experience regionally, this is a rough estimate. The cost for base aggregate will vary significantly depending on base depth for stormwater storage and is not included in the cost estimate (PSAT, 2005).

5-4.2.2 Dispersion BMPs

FC.01 – Natural Dispersion



Natural Dispersion Area Along SR 516 in King County.

Introduction

General Description

Natural dispersion is the simplest method of flow control and runoff treatment. This BMP can be used for impervious or pervious surfaces that are graded to avoid concentrating flows. Natural dispersion uses the existing vegetation, soils, and topography to effectively provide flow control and runoff treatment. It generally requires little or no construction activity. Site selection is very important to the success of this BMP. The pollutant-removal processes include infiltration into the existing soils and through vegetation root zones; evaporation; and uptake and transpiration by the vegetation.

The key to natural dispersion is that flows from the impervious area enter the natural dispersion area as sheet flow. Because stormwater enters the dispersion area as sheet flow, it only needs to traverse a narrow band of contiguous vegetation for effective attenuation and treatment. The goal is to have the flows dispersed into the surrounding landscape such that there is a low probability any surface runoff will reach a flowing body of water.

Using natural dispersion on projects will result in benefits when determining applicable minimum requirements and thresholds. New impervious surfaces that drain to dispersion areas should be accounted for when determining the project's total new impervious surface area, but the area should be counted as a noneffective impervious surface (and noneffective

PGIS). When modeling the hydrology of the project site and threshold discharge area, the designer should treat natural dispersion areas and their tributary drainage areas as disconnected from the project site because they do not contribute flow to other flow control or runoff treatment BMPs.

Applications and Limitations

Applications

- Natural dispersion is ideal for highways and linear roadway projects.
- There are two types of natural dispersion: sheet flow dispersion and channelized dispersion.
- Natural dispersion helps maintain the temperature norms of stormwater because it promotes infiltration, evaporation, and transpiration and should not have a surface discharge to a lake or stream.
- Natural dispersion areas meet basic and enhanced runoff treatment criteria set forth in Minimum Requirement 5 (Runoff Treatment) in Section 3.3.5.
- Natural dispersion areas meet flow control criteria set forth in Minimum Requirement 6 (Flow Control) in Section 3.3.6.

Limitations

- The effectiveness of natural dispersion relies on maintaining sheet flow to the dispersion area, which maximizes soil and vegetation contact and prevents short-circuiting due to channelized flow. If sheet flow cannot be maintained, natural dispersion will not be effective.
- Natural dispersion areas must be protected from future development. (See the *Site Design Elements* section of this BMP.) WSDOT may ultimately have to purchase right of way or easements to satisfy the criteria for natural dispersion areas, but this should be the last option a designer should choose.
- Natural dispersion areas initially may cost as much as other constructed BMPs (ponds or vaults) because right of way or easements often need to be purchased, but long-term maintenance costs are lower. These natural areas will also contribute to the preservation of native habitat and provide visual buffering of the roadway.
- Refer to the Glossary for “noneffective PGIS” and “noneffective impervious surfaces” to see how natural dispersion areas are analyzed with respect to minimum requirements.
- Floodplains are not suitable areas for natural dispersion. In these situations, please contact the Region or HQ Hydraulics Office.

The following are additional limitations for sites where runoff is channelized upstream of the dispersion area:

- The channelized flow must be redispersed before entering the natural dispersion area. Dispersal BMPs create sheet flow conditions.
- Energy dissipaters in conjunction with dispersal BMPs may be needed to prevent high velocities through the natural dispersion areas.
- Channelized flows are limited to on-site flows. Parallel conveyance systems may be needed to separate off-site flows. There may be situations where it might be more beneficial to disperse off-site flows. In these situations, please contact the Region or HQ Hydraulics Office.

Site Design Elements

Siting Criteria

The key to natural dispersions is having vegetative land cover with a good established root zone where the roots, organic matter, and soil macroorganisms provide macropores to reduce surface compaction and prevent soil pore sealing. The vegetative cover also provides filtration and maintains sheet flow, reducing the chance for erosion. The following areas are considered appropriate candidates for natural dispersion because they are likely to retain these vegetative conditions over the long term:

- WSDOT rights of way
- Protected beautification areas
- Agricultural areas
- State parks
- Commercial or government-owned forest lands
- Rural areas with zoned densities of less than one dwelling unit per 5 acres

Note: Though natural dispersion areas should be adjacent to the project site, they do not have to be immediately adjacent to the length of the roadway.

Design Flow Elements

Flows to Be Dispersed

The size of the natural dispersion area depends on the flow contributing area and the predicted rates of water loss through the dispersion system. The designer should ensure the dispersion area is sufficient to dispose the runoff through infiltration, evaporation, transpiration, and soil absorption.

Sheet Flow

Sheet flow dispersion criteria for natural dispersion areas are as follows:

- The sheet flow path leading to the natural dispersion area should not be longer than 150 feet. The sheet flow path is measured in the direction of flow and generally represents the width of the pavement area.
- Pervious shoulders and side slopes are not counted in determining the sheet flow path.
- The longitudinal length of the dispersion area should be equivalent to the longitudinal length of roadway that is contributing sheet flow.
- The longitudinal pavement slope contributing flow to a dispersion area should be less than 5%. The lateral pavement slope should be less than 8%.
- Roadway side slopes leading to natural dispersion areas should be 25% (4H:1V) or flatter. Slopes steeper than 25% are allowed if the existing side slopes are well vegetated and show no signs of erosion problems.
- For any existing slope that will lead to a natural dispersion area, if evidence of channelized flow (rills or gullies) is present, a flow spreading device should be used before those flows are allowed to enter the dispersion area.

Sizing Criteria*Sheet flow*

There are two sheet flow options that can be applied to size natural dispersion areas. The first option, described below, is based on a simplified equation (termed the LID Design Equation¹) that was derived from a water balance model and is applicable only to eastern Washington. This equation takes into account the roadway width, saturated hydraulic conductivity, and rainfall intensity to derive the width needed for the natural dispersion. The second option is based on soil characteristics and is described after Option 1.

Option 1 – Design Process (eastern Washington only):

$$LID = \frac{ACP}{\frac{K_s}{r_i} - 1}$$

¹ “Application of a Simplified Analysis Method for Natural Dispersion of Highway Stormwater Runoff,” WA-RD 618.1, Research Report, August 2005

where:

- LID = width of the natural dispersion in feet
 ACP = width of the roadway in feet
 K_s = saturated hydraulic conductivity in inches per hour (see Section 4-5.2)
 r_i = rainfall intensity in inches per hour

The K_s/r_i ratio must be greater than 2 for natural dispersion to have a viable benefit. If the ratio is less than 1 or equal to 1, the equation is not valid and will result in negative values.

Calculating Rainfall Intensity in Eastern Washington:

The rainfall intensity (r_i) is the peak 5-minute intensity of the 6-month, 3-hour short-duration storm. To calculate r_i , multiply the rainfall depth (2-year, 2-hour) by the *Peak Intensity Factor (PIF)* based on its Mean Annual Precipitation for the area. Use the table below to convert the Mean Annual Precipitation value to *PIF*.

The 2-year, 2-hour rainfall depth information is contained in Appendix 4A – Web Links, under the Eastern Washington Isopluvial and Mean Annual Precipitation Map. WSDOT's ArcMap GIS system also contains this information.

$$r_i = 2\text{-year, 2-hour rainfall depth} * PIF$$

DOE Climate Region #	Mean Annual Precipitation	Isopluvial to Peak Intensity Factor:
2	6-8	1.85
	8-10	1.88
	10-12	1.94
2-3	12-16	2.00
3	16-22	2.03
1-4	22-28	2.09
	28-40	2.12
	40-60	2.19
	60-120	2.25

Example:

Spokane 2-year, 2-hour rainfall depth = 0.48 inches
 Spokane Mean Annual Precipitation depth = 18 inches
 Spokane *PIF* for 18 inches = 2.03 in/hr

Calculate r_i = 0.48 in * 2.03 in/hr
 = 0.97 in/hr

Option 2 – Based on Soil Characteristics

The following criteria are specific to sheet flow dispersion on all Type A and some Type B soils (depending on saturated hydraulic conductivity rates):

- For saturated hydraulic conductivity rates (as determined in Section 4-5.2) of 4 inches per hour or greater and for the first 20 feet (along the sheet flow path) of impervious surface that drains to the dispersion area, there must be 10 lateral feet of dispersion area width. For each additional foot of impervious surface (along the sheet flow path) that drains to the dispersion area, 0.25 lateral feet of dispersion area should be provided.
- For dispersion areas that receive sheet flow from only disturbed pervious areas (bare soil and non-native landscaping), for every 6 feet (along the sheet flow path) of disturbed pervious area, 1 lateral foot width of dispersion area is required.

The following criteria are specific to sheet flow dispersion on all Type C and D soils and some Type B soils with saturated hydraulic conductivity rates of 4 inches per hour or less:

- For every 1 foot of contributing pavement width, a dispersion area width of 6.5 feet is needed.
- The dispersion area should have a minimum width of native vegetation of 100 feet (measured in the direction of the flow path).

Figure FC.01.1 illustrates the configuration of a typical natural dispersion area relative to the roadway.

Channelized Flow

Channelized flow dispersion criteria for Type A, B, C, and D soils are as follows:

- Concentrated runoff from the roadway and adjacent upstream areas (such as in a ditch or cut slope) must be incrementally discharged from the conveyance system (such as a ditch, gutter, or storm sewer) via cross culverts or at the ends of cut sections. These incremental discharges of newly concentrated flows must not exceed 0.5 cubic feet per second (cfs) at any single discharge point from the conveyance system for the 100-year runoff event (determined by an approved continuous flow model as described in Chapter 4). Where flows at a particular discharge point are already concentrated under existing site conditions (for example, in a natural channel that crosses the roadway alignment), the 0.5-cfs limit would be in addition to the existing concentrated peak flows.

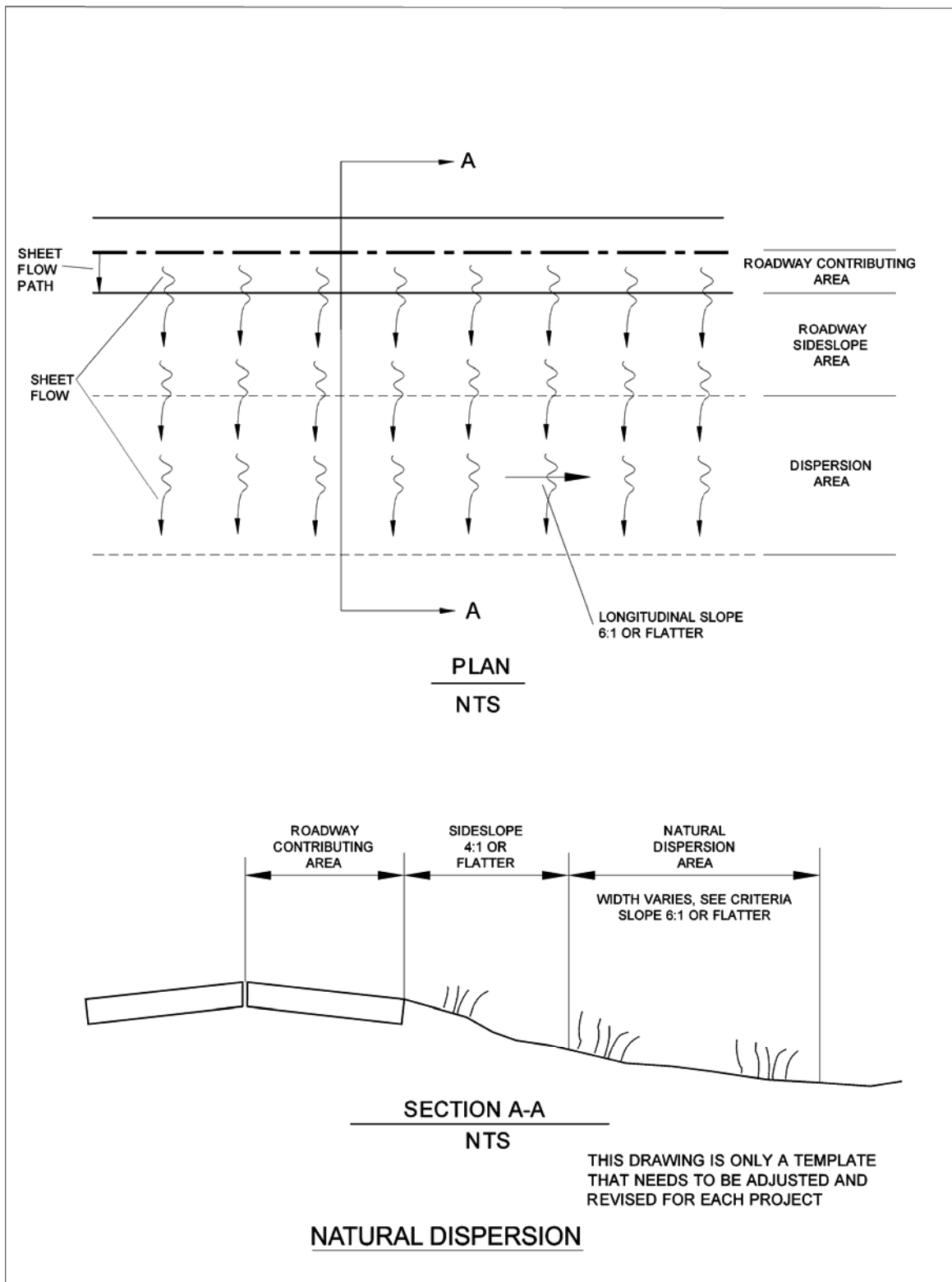

Figure FC.01.1. Natural dispersion area.

- Discharge points with up to 0.2 cfs discharge for the peak 100-year flow may use rock pads or dispersion trenches to disperse flows. Discharge points with between 0.2 and 0.5 cfs discharge for the 100-year peak flow must use only dispersion trenches to disperse flows.
- Dispersion trenches must be designed to accept surface flows (free discharge) from a pipe, culvert, or ditch end; aligned perpendicular to the flow path; a minimum of 2 feet by 2 feet in section; 50 feet in length; filled with $\frac{3}{4}$ - to 1½-inch washed rock; and provided with a level notched grade board (see Sections 5-4.3.4 and 5-4.3.5). Manifolds may be used to split flows up to 2 cfs discharge for the 100-year peak flow between four trenches (maximum). Dispersion trenches must have a minimum spacing of 50 feet.
- After being dispersed with rock pads or trenches, flows from discharge points must traverse the required flow path length of the dispersion area before entering an existing on-site channel carrying existing concentrated flows away from the roadway alignment.

Note: To provide the required flow path length to an existing channel, some roadway runoff may unavoidably enter the channel undispersed.

- Flow paths from adjacent discharge points must not intersect within the required flow path lengths, and dispersed flow from a discharge point must not be intercepted by another discharge point.
- Ditch discharge points must be located a minimum of 100 feet upgradient of steep slopes (slopes steeper than 40% within a vertical elevation change of at least 10 feet), wetlands, and streams.
- Where the local jurisdiction determines that there is a potential for significant adverse impacts downstream (such as erosive steep slopes or existing downstream drainage problems), dispersion of roadway runoff may not be allowed, or other measures may be required.

The following criterion is specific to channelized flow dispersion on all Type A and some Type B soils, depending on saturated hydraulic conductivity rates.

- For saturated hydraulic conductivity rates (as determined in Section 4-5.2) of 4 inches per hour or greater, the dispersion area should be at least 50% of the tributary drainage area.

The following criteria are specific to channelized flow dispersion on all Type C and D soils and some Type B soils, depending on saturated hydraulic conductivity rates.

- For every 1 foot of contributing pavement width, a dispersion area width of 6.5 feet is needed.

- The dispersion area should have a minimum width of native vegetation of 100 feet, measured in the direction of the flow path.

Pipe or Ditch Conveyance System

Flows collected in a pipe or ditch conveyance system require energy dissipation and dispersal at the end of the conveyance system before entering the dispersion area. For flow dispersal BMPs (such as gravel-filled trenches or level spreaders) and techniques, see Sections 5-4.3.4 and 5-4.3.5. (See the *Hydraulics Manual* for energy dissipater designs and considerations.)

Structural Design Considerations

Geometry

Natural dispersion areas should have the following attributes:

- Be well vegetated with established root zones
- Have an average longitudinal slope of 6H:1V or flatter
- Have an average lateral slope of 6H:1V or flatter for both the roadway side slope and natural area to be part of the natural dispersion area
- Have infiltrative soil properties that are verified by the WSDOT Materials Lab, the Regional Materials Engineer, or a geotechnical engineer

Natural dispersion areas that have impervious areas (for example, abandoned roads with compacted subgrades) within them should have those areas tilled and restored using the soil amendments described in Section 5-4.3.2.

Natural dispersion areas that are within a landslide hazard area must be evaluated by a geotechnical engineer or qualified geologist.

Natural dispersion areas should have a separation of at least 3 feet between the existing ground elevation and the average annual maximum groundwater elevation. This separation depth requirement applies to the entire limits of the dispersion area. There should be no discernible continuous flow paths through the dispersion area.

When selecting natural dispersion areas, the designer should determine whether there are groundwater management plans for the area and contact the local water purveyors to determine whether the project lies within a wellhead or groundwater protection zone, septic drain fields, or aquifer recharge area. These areas typically restrict stormwater infiltration; however, the local jurisdiction may waive this requirement. Designers should contact Region Hydraulics Office personnel for assistance in these situations.

The WSDOT GIS Workbench (an ArcView geographic information system tool maintained by the HQ Geographic Services Division and the HQ Office of Information Technology to provide staff with access to comprehensive, current, and detailed environmental and natural

resource management data) may be a source of initial information about wells within the project limits.

Intent: Natural dispersion areas are not likely to have a uniform slope across their entire area. As a result, there are ponding areas and uneven terrain. Minor channelization of flow within the dispersion area is expected. However, a continuous flow path through the entire dispersion area disqualifies its use as a BMP because channelized flow promotes erosion of the channel that carries the flow and greatly reduces the potential for effective pollutant removal and peak flow attenuation.

Setback Requirements

- Natural dispersion areas can extend beyond WSDOT right of way provided that documentation on right of way plans ensures (via easements) the dispersion area is not developed in the future.
- Natural dispersion areas should be set back at least 100 feet from drinking water wells, septic tanks or drain fields, and springs used for public drinking water supplies. Natural dispersion areas upgradient of drinking water supplies and within the 1-, 5-, and 10-year time of travel zones must comply with the Washington State Department of Health (DOH) requirements (Washington Wellhead Protection Program, DOH, 12/93).
- The designer should check with the local jurisdiction for additional setback requirements.
- If the project significantly increases flows to off-site properties, a drainage easement may be required or additional right of way may be purchased.

Signage

- The limits of the natural dispersion area should be marked as a stormwater management facility on WSDOT right of way sheets and also should be physically marked in the field (during and after construction). Signage ensures the natural dispersion area is protected from construction activity disturbance and is adequately protected by measures shown in the temporary erosion and sedimentation control (TESC) plan.
- Signage helps ensure the natural dispersion area is not cleared or disturbed after the construction project.

Construction Considerations

- For installation of dispersal BMPs and conveyance systems near dispersion areas, the area that needs to be cleared or grubbed should be minimized. Maintaining plant root systems is important for dispersion areas.
- The area around dispersion areas should not be compacted.

- To the maximum extent practicable, low-ground-pressure vehicles and equipment should be used during construction.

Maintenance Considerations

- Maintenance pullout areas should be considered to promote successful maintenance practices at dispersion areas. Pullout areas should be large enough to accommodate a typical maintenance vehicle. Please contact the local maintenance office to determine the typical size of maintenance vehicle used at the project site.
- General maintenance criteria should follow Table 5.5.7 (energy dissipaters).

FC.02 – Engineered Dispersion



Engineered Dispersion Area Along I-5.

Introduction

General Description

Engineered dispersion is similar to natural dispersion. This BMP can be used for impervious or pervious surfaces that are graded to drain via sheet flow or are graded to collect and convey stormwater to engineered dispersion areas after going through a flow spreading or energy dissipater device. Engineered dispersion uses the existing vegetation or landscaped areas, existing soils or engineered compost-amended soils, and topography to effectively provide flow control and runoff treatment. This type of dispersion may require major or minor construction activity depending on the existing site conditions. Site selection is very

important to the success of this BMP. The pollutant-removal processes include infiltration to the existing or engineered soils and through vegetation root zones; evaporation; and uptake and transpiration by the existing vegetation or landscaped areas.

The key to effective engineered dispersion is that flows from the impervious area enter the dispersion area as sheet flow. Because stormwater enters as sheet flows to the dispersion area, it need only traverse a band of contiguous vegetation and compost-amended soils for effective attenuation and treatment. This differs from natural dispersion in that flows may not have previously (preproject) been directed to the selected engineered dispersion area. Absorption capacity can be gained by using compost-amended soils to disperse and absorb contributing flows to the dispersion area. The goal is to have the flows dispersed into the surrounding landscape such that there is a low probability that any surface runoff will reach a flowing body of water.

Applications and Limitations

Applications

- Engineered dispersion is ideal for highways and linear roadway projects that collect and convey stormwater to discrete discharge points along the project.
- Engineered dispersion maintains temperature norms of stormwater because it promotes infiltration, evaporation, and transpiration and should not have a surface discharge to a lake or stream.
- Engineered dispersion areas meet basic and enhanced runoff treatment criteria set forth in Minimum Requirement 5 (Runoff Treatment) in Section 3.3.5.
- Engineered dispersion areas meet flow control criteria set forth in Minimum Requirement 6 (Flow Control) in Section 3.3.6.

Limitations

- The effectiveness of engineered dispersion relies on maintaining sheet flow to the dispersion area, which maximizes soil and vegetated contact and prevents short-circuiting due to channelized flow. If sheet flow cannot be maintained, engineered dispersion will not be effective.
- The project must ensure the engineered dispersion area is not developed in the future. An easement or agreement with the property owner may be needed or additional right of way acquisition may be necessary.
- Engineered dispersion areas may cost as much as other BMPs (ponds or vaults) because right of way and easements may need to be purchased and compost-amended soils may need to be added.
- Floodplains are not suitable areas for engineered dispersion. In these situations, please contact the Region or HQ Hydraulics Office.

Design Flow Elements

Flows to Be Dispersed

The required size of the engineered dispersion area depends on the area contributing flow and the predicted rates of water loss through the dispersion system. The designer should ensure the dispersion area is able to dispose of (through infiltration, evaporation, transpiration, and soil absorption) stormwater flows predicted by an approved continuous runoff model.

Because a water balance model has not yet been developed for designing engineered dispersion areas, a set of conservative guidelines similar to those given for natural dispersion have been agreed upon by WSDOT and Ecology. Designers should check with Region or HQ Hydraulics Office staff for updates to the engineered dispersion criteria.

Structural Design Considerations

Geometry

- The average longitudinal slope of the dispersion area should not exceed 6H:1V.
- The average lateral slope of the dispersion area should not exceed 6H:1V.
- There should be no discernible flow paths through the dispersion area.
- There should be no surface water discharge from the dispersion area to a conveyance system or Category I and II wetlands (as defined by Ecology's Wetland Rating Systems for western and eastern Washington).

Materials

- Compost-amended soils should be generously applied to the dispersion areas. The final organic content of the soil in the dispersion areas should be 10%. Design information for determining the amount and type of compost needed and the necessary planted vegetation to meet those requirements is given in Section 5-4.3.2.

Site Design Elements

Siting Criteria

The following areas are appropriate engineered dispersion areas because they are likely to remain in their existing condition over the long term:

- WSDOT rights of way
- Protected beautification areas
- Agricultural areas
- State parks
- Commercial or government-owned forestlands

- Rural areas with zoned densities of less than one dwelling unit per 5 acres

Engineered dispersion areas should have infiltrative soil properties that are verified by the WSDOT Materials Lab or a geotechnical engineer using the testing methods in Chapter 4.

Engineered dispersion areas that have impervious areas (such as abandoned roads with compacted subgrades) within them should have those areas tilled and reverted using the soil amendments described in Section 5-4.3.2.

Engineered dispersion areas that are within a landslide hazard area must be evaluated by a geotechnical engineer or qualified geologist. Engineered dispersion areas should not be sited above slopes greater than 20% or above erosion hazard areas without evaluation by a geotechnical engineer or qualified geologist and approval by the local jurisdiction.

Engineered dispersion areas should have a separation of at least 3 feet between the existing ground elevation and the average annual maximum groundwater elevation.

When selecting engineered dispersion areas, the designer should determine whether there are groundwater management plans for the area and contact the local water purveyors to determine whether the project lies within a wellhead or groundwater protection zone, septic drain fields, or aquifer recharge area. These areas typically restrict stormwater infiltration; however, the local jurisdiction may waive this requirement. The WSDOT GIS Workbench may be a source of initial information about wells within the project limits.

Sizing Criteria

Figure FC.02.1 illustrates a typical engineered dispersion area relative to the adjacent roadway.

Sheet Flow

Sheet flow dispersion criteria for Type A, B, C, and D soils are as follows:

- The sheet flow path leading to the engineered dispersion area should not be longer than 150 feet. The sheet flow path is measured in the direction of flow and generally represents the width of the pavement area.
- Pervious shoulders and side slopes are not counted in determining the sheet flow path.

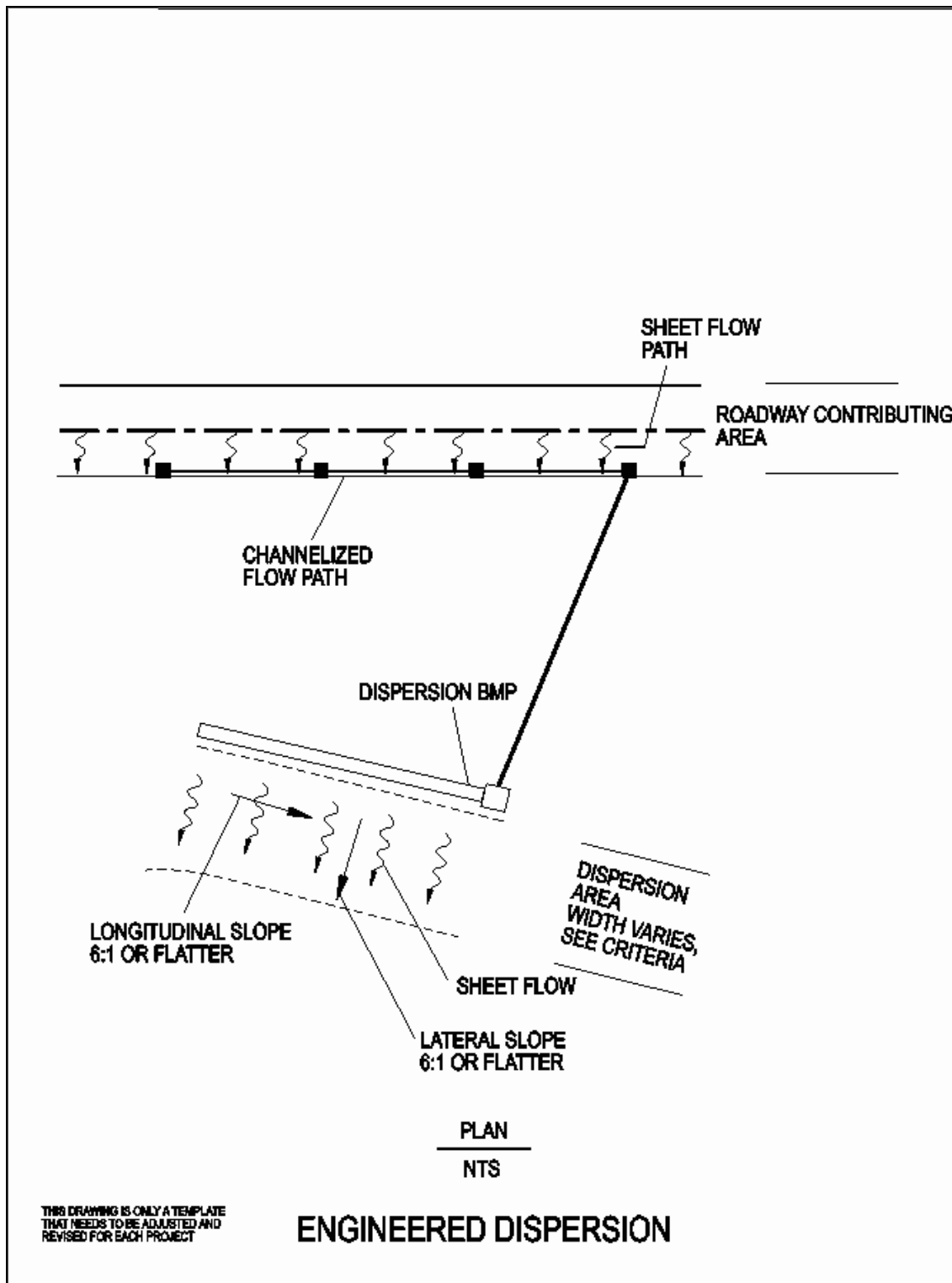

Figure FC.02.1. Engineered dispersion area.

- The longitudinal length of the dispersion area should be equivalent to the longitudinal length of the roadway that is contributing sheet flow.
- Roadway side slopes leading to engineered dispersion areas should be 25% (4H:1V) or flatter. Roadway side slopes that are 25% to 15% (7H:1V) should not be considered part of the dispersion area. Slopes steeper than 25% are allowed if the existing side slopes are well vegetated and show no signs of erosion problems. For any existing slope that will lead to an engineered dispersion area, if evidence of channelized flow (rills or gullies) is present, a flow-spreading device should be used before those flows are allowed to enter the dispersion area.
- Roadway side slopes that are 15% or flatter are considered part of the dispersion area if engineered dispersion practices are applied to the slope (6.5 feet of compost-amended side slope width mitigates for 1 foot of impervious surface). The use of natural and engineered dispersion concepts within one threshold discharge area is acceptable.

The following criteria are specific to sheet flow dispersion on all Type A and some Type B soils, depending on saturated hydraulic conductivity rates:

- For saturated hydraulic conductivity rates (as determined in Section 4-5.2) of 4 inches per hour or greater, and for the first 20 feet (along the sheet flow path) of impervious surface that drains to the dispersion area, there must be 10 lateral feet of dispersion area width. For each additional foot of impervious surface (along the sheet flow path) that drains to the dispersion area, 0.25 lateral feet of dispersion area should be provided.
- For dispersion areas that receive sheet flow only from disturbed pervious areas (bare soil and non-native landscaping), for every 6 feet (along the sheet flow path) of disturbed pervious area, 1 lateral foot width of dispersion area is required.

The following criteria are specific to sheet flow dispersion on all Type C and D soils and some Type B soils, depending on saturated hydraulic conductivity rates:

- For every 1 foot of contributing pavement width, a dispersion area width of 6.5 feet is needed
- The dispersion area should have a minimum width of 100 feet, measured in the direction of the flow path

Channelized Flow

Channelized flow dispersion criteria for Type A, B, C, and D soils are as follows:

- Concentrated runoff from the roadway and adjacent upstream areas (for example, in a ditch or cut slope) must be incrementally discharged from the conveyance system (such as a ditch, gutter, or storm sewer) via cross culverts or at the ends of cut sections. These incremental discharges of newly concentrated flows must not exceed 0.5 cfs at any single discharge point from the conveyance system for the 100-year runoff event (determined by an approved continuous flow model as described in Chapter 4). Where flows at a particular discharge point are already concentrated under existing site conditions (for example, in a natural channel that crosses the roadway alignment), the 0.5-cfs limit would be in addition to the existing concentrated peak flows.
- Discharge points with up to 0.2 cfs discharge for the peak 100-year flow may use rock pads or dispersion trenches to disperse flows. Discharge points with between 0.2 and 0.5 cfs discharge for the 100-year peak flow must use only dispersion trenches to disperse flows.
- Dispersion trenches must be designed to accept surface flows (free discharge) from a pipe, culvert, or ditch end; aligned perpendicular to the flow path; a minimum of 2 feet by 2 feet in section; 50 feet in length; filled with $\frac{3}{4}$ - to 1½-inch washed rock; and provided with a level notched grade board (see Sections 5-4.3.4 and 5-4.3.5). Manifolds may be used to split flows up to 2 cfs discharge for the 100-year peak flow between four trenches (maximum). Dispersion trenches must have a minimum spacing of 50 feet.
- After being dispersed with rock pads or trenches, flows from discharge points must traverse the required flow path length of the dispersion area before entering an existing on-site channel carrying existing concentrated flows away from the roadway alignment.

Note: To provide the required flow path length to an existing channel, some roadway runoff may unavoidably enter the channel undispersed.

- Flow paths from adjacent discharge points must not intersect within the required flow path lengths, and dispersed flow from a discharge point must not be intercepted by another discharge point.
- Discharge points must be located a minimum of 100 feet upgradient of steep slopes (slopes steeper than 40% within a vertical elevation change of at least 10 feet), wetlands, and streams.
- Where the local jurisdiction determines that there is a potential for significant adverse impacts downstream (for example, erosive steep slopes or existing downstream drainage problems), dispersion of roadway runoff may not be allowed, or other measures may be required.

The following criterion is specific to channelized flow dispersion on all Type A and some Type B soils, depending on saturated hydraulic conductivity rates:

- For saturated hydraulic conductivity rates (as determined in Section 4-5.2) of 4 inches per hour or greater, and for the first 20 feet (along the sheet flow path) of impervious surface that drains to the dispersion area, there must be 10 lateral feet of dispersion area width. For each additional foot of impervious surface (along the sheet flow path) that drains to the dispersion area, 0.25 lateral feet of dispersion area should be provided.

The following criteria are specific to channelized flow dispersion on Type C and D soils and some Type B soils, depending on saturated hydraulic conductivity rates:

- For every 1 foot of contributing pavement width, a dispersion area width of 6.5 feet is needed
- The dispersion area should have a minimum width of 100 feet, measured in the direction of the flow path

Pipe or Ditch Conveyance System

- Flows collected in a pipe or ditch conveyance system require energy dissipation and dispersal at the end of the conveyance system before entering the dispersion area. For flow dispersal BMPs (such as gravel-filled trenches or level spreaders) and techniques, see Sections 5-4.3.4 and 5-4.3.5. (See the *Hydraulics Manual* for energy dissipater designs and considerations.)

Setback Requirements

- Engineered dispersion areas can extend beyond WSDOT right of way, provided that documentation on right of way plans ensures (via easement or agreement) the dispersion area is not developed in the future.
- Engineered dispersion areas should be set back at least 100 feet from drinking water wells, septic tanks or drain fields, and springs used for public drinking water supplies. Engineered dispersion areas upgradient of drinking water supplies and within the 1-, 5-, and 10-year time of travel zones must comply with DOH requirements (Washington Wellhead Protection Program, DOH, 12/93).
- The designer should check with the local jurisdiction for additional setback requirements.
- If the project significantly increases flows to off-site properties, a drainage easement may be required or right of way purchased.

Signage

- The limits of the engineered dispersion area should be marked as a stormwater management facility on WSDOT right of way sheets and should also be

physically marked in the field (during and after construction). Signage ensures that the engineered dispersion area is protected from construction activity disturbance and is adequately protected by measures shown in the TESC plan.

- Signage helps ensure the engineered dispersion area is not cleared or disturbed after the construction project.

Construction Considerations

- For installation of dispersal BMPs and conveyance systems near dispersion areas, the area that needs to be cleared or grubbed should be minimized. Maintaining plant root systems is important for dispersion areas.
- The area around dispersion areas should not be compacted.
- To the maximum extent practicable, low-ground-pressure vehicles and equipment should be used during construction.

Maintenance Considerations

- Maintenance pullout areas should be considered to promote successful maintenance practices of dispersion areas. Pullout areas should be large enough to accommodate a typical maintenance vehicle. Please contact the local maintenance office to determine the typical size of maintenance vehicle used at the project site.
- General maintenance criteria should follow Table 5.5.7 (energy dissipaters) and Table 5.5.9 (vegetated filter strips).

5-4.2.3 Detention BMPs

FC.03 – Detention Pond



Detention Pond Along SR 18 in King County.

Introduction

General Description

Detention ponds are open basins that provide live storage volume to enable reduction of stormwater runoff flow rates and matching of predeveloped flow durations discharged from a project site (see Figures FC.03.1, FC.03.2, and FC.03.3). Detention ponds are commonly used for flow control in locations where space is available for an aboveground stormwater facility but where infiltration of runoff is infeasible. Detention ponds are designed to drain completely after a storm event so that the live storage volume is available for the next event.

Applications and Limitations

Infiltration of runoff is the preferred method of flow control following appropriate runoff treatment. However, in areas where infiltration is not feasible, runoff detention must be implemented.

Detention ponds are designed to drain completely between storm events. They can be combined with wet pool runoff treatment BMPs to make more effective use of available land area (see BMP CO.01, Combined Wet/Detention Pond, and BMP CO.02, Combined Stormwater Treatment Wetland/Detention Pond).

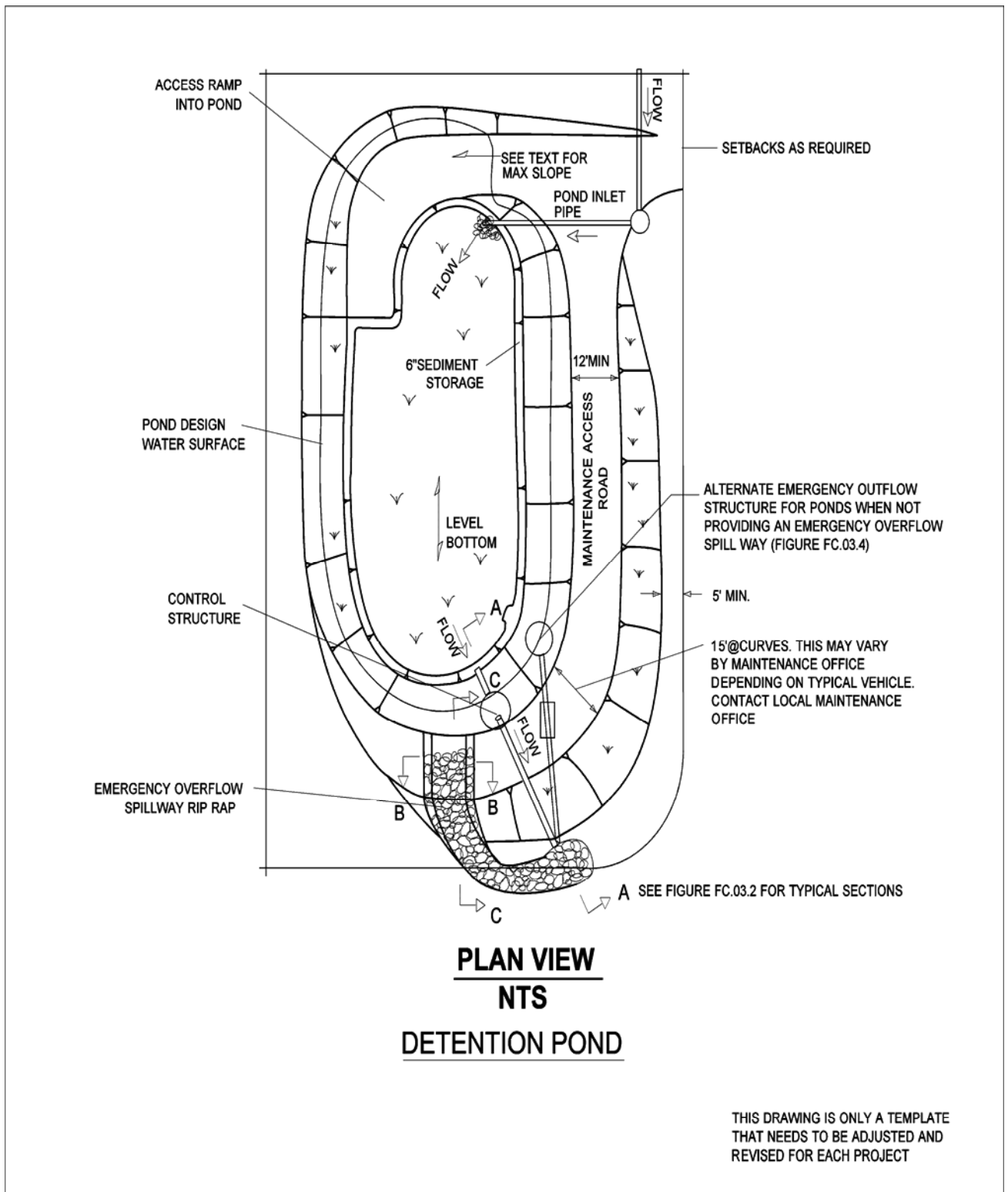

Figure FC.03.1. Detention pond.

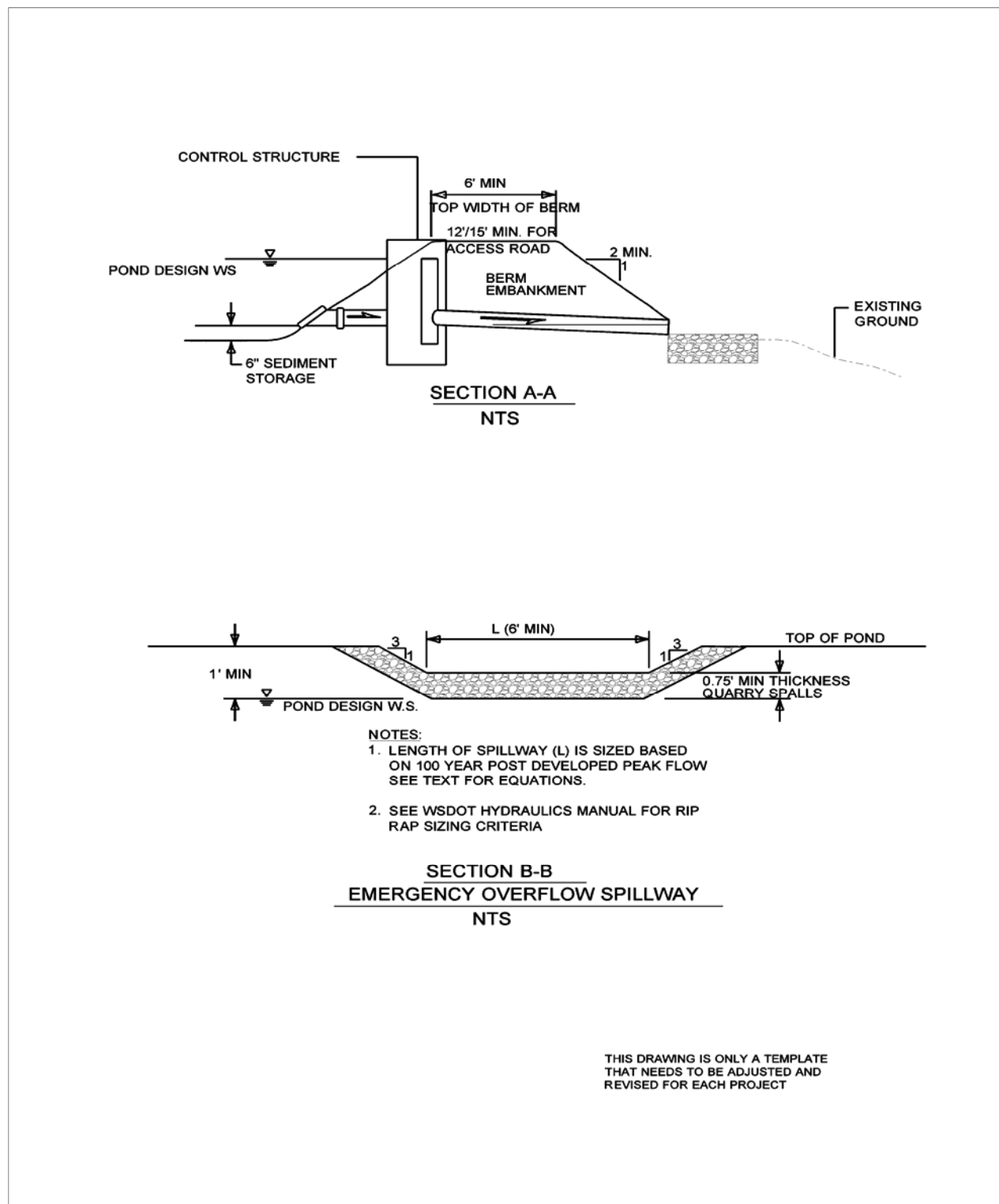

Figure FC.03.2. Detention pond: Cross sections.

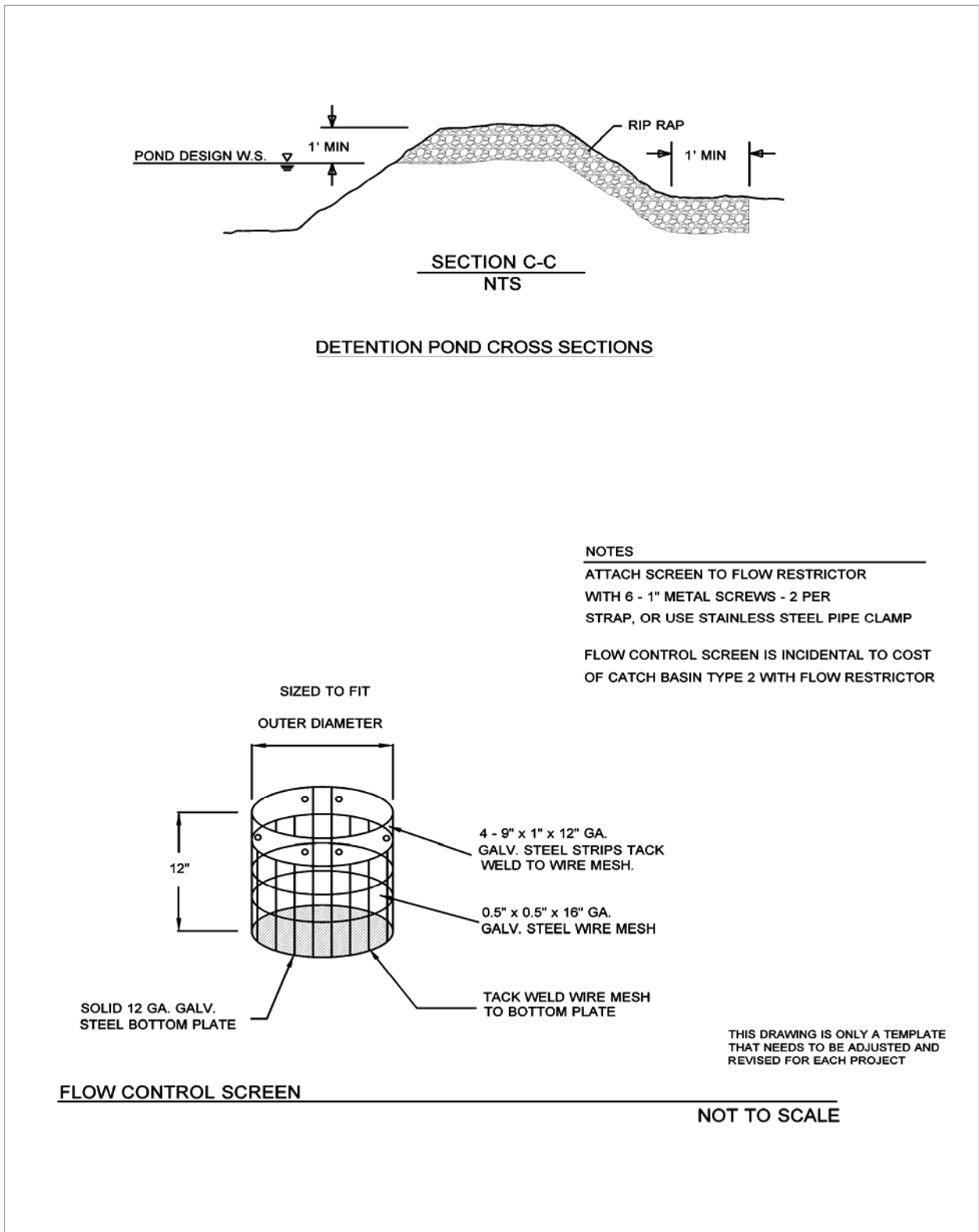

Figure FC.03.3. Detention pond: Cross sections.

Design Flow Elements

Flows to Be Detained

The volume and outflow design for detention ponds with a minimum 1-foot freeboard above the design water surface elevation must be determined in accordance with the flow control criteria presented in Section 3-3.6 under Minimum Requirement 6 (Flow Control). The design water surface elevation is the highest water surface elevation that is projected in order to satisfy the flow control requirements listed in Table 3-6 for western Washington and Table 3-7 for eastern Washington. Hydrologic analysis and design methods are presented in Sections 4-3.6.1 for western Washington and 4-4.5 for eastern Washington. Designers should read these sections for guidelines on how to incorporate the detention pond water surface into the flow control modeling.

Note: If the inlet pipe is submerged below the design water surface elevation, the designer shall then compute the hydraulic grade line (HGL) of the inlet pipe to verify that backwater conditions are acceptable. (See the *Hydraulics Manual* for computing an HGL.)

Detention Ponds in Infiltrative Soils

Detention ponds may occasionally be sited on soils that are sufficiently permeable for a properly functioning infiltration system. These detention ponds have both a surface discharge and a subsurface discharge. If infiltration is accounted for in the detention pond sizing calculations, the pond design process and corresponding site conditions must meet all the requirements for infiltration ponds (see BMP IN.02), including a soils report, soil infiltration testing, groundwater protection, presettling, and construction techniques.

Overflow or Bypass

A primary overflow (usually a riser pipe within the outlet control structure) must be provided for the detention pond system to bypass the 100-year postdeveloped peak flow over or around the flow restrictor system. Overflow can occur when the facility is full of water due to plugging of the outlet control structure or high inflows; the primary overflow is intended to protect against breaching of the pond embankment (or overflows of the upstream conveyance system). The design must provide controlled discharge of pond overflows directly into the downstream conveyance system or another acceptable discharge point.

A secondary inlet to the pond discharge control structure can be provided as additional protection against overflows should the designer determine that the primary inlet pipe to the control structure would likely become plugged. In these situations, the designer should first consult with the area maintenance office to decide whether a secondary inlet to the control structure would be appropriate. One option for the secondary inlet is a grated opening (called a jailhouse window) in the control structure that functions as a weir when used as a secondary inlet. Contact the Region Hydraulics Office staff for the specific structural design modification requirements on this design option.

Another common option for a secondary inlet is to allow flow to spill into the top of the discharge control structure, or another structure linked to the discharge control structure, that is fitted with a debris cage (called a birdcage; see [Figure FC.03.4](#)). Other options can be used for secondary inlets, subject to assurance that they would not be plugged by the same mechanism that plugged the primary inlet pipe. The maximum circumferential length of a jailhouse window weir opening must not exceed one-half the control structure circumference.

Outlet Control Structure

Control structures are catch basins or manholes with a restrictor device for controlling outflow from a facility to meet the desired performance. Riser-type restrictor devices (tees or FROP-Ts) also provide some incidental oil/water separation to temporarily detain oil or other floatable pollutants in runoff due to accidental spill or illegal dumping.

The restrictor device usually consists of two or more orifices or an orifice/weir section sized to meet performance requirements.

Standard control structure details are shown in the *Standard Plans*.

Multiple Orifice Restrictor

In most cases, control structures need only two orifices: one at the bottom and one near the top of the riser (although additional orifices may optimize the detention storage volume). Several orifices may be located at the same elevation if necessary to meet performance requirements.

- The minimum circular orifice diameter is 0.5 inches. For orifices that have a diameter of less than 1 inch, the designer should consider using a flow screen that fits over the orifice to help prevent plugging. (See [Figure FC.03.3](#) for more details on orifice screens.)
- The minimum vertical rectangular orifice length is 0.25 inches.
- Orifices may be constructed on a tee section as shown in the *Standard Plans*.
- In some cases, performance requirements may require the top orifice or elbow to be located too high on the riser to be physically constructed (for example, a 13-inch-diameter orifice cannot be positioned 6 inches from the top of the riser). In these cases, a notch weir in the riser pipe may be used to meet performance requirements.

Consideration must be given to the backwater effect of water surface elevations in the downstream conveyance system. High tailwater elevations may affect performance of the restrictor system and reduce live storage volumes. If these conditions are present, see Section 8.4 of the *MGSFlood Users Manual* for further design guidelines.

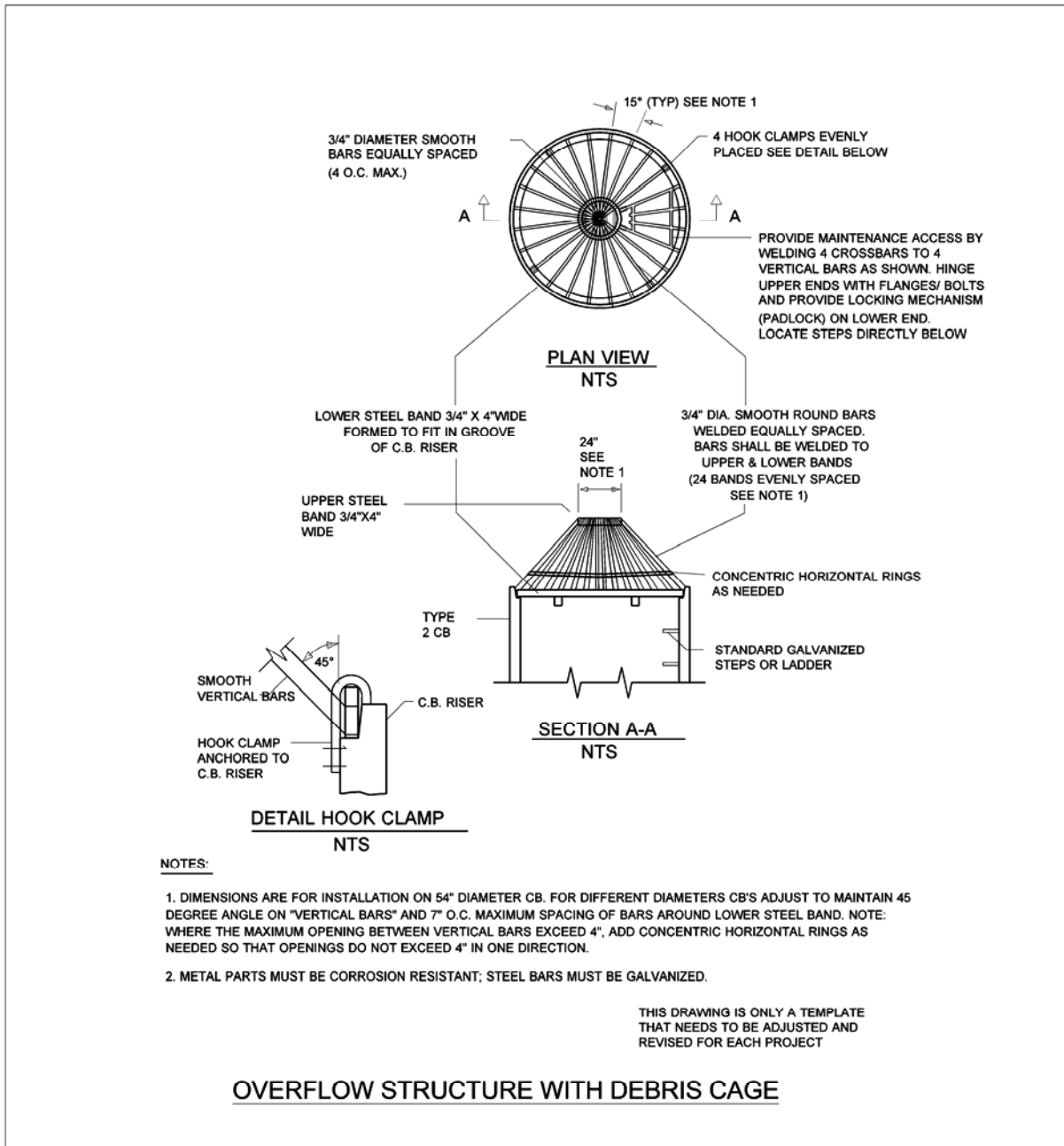

HEC Dwg File: S:\gher.dwgname) Layout: S:\gher.cad) Last Edited: S:\edits.S\gher.dwgdate) yyyy/mm/dd hh:mm
 HEC Location: S:\gher.dwgpath)

Figure FC.03.4. Overflow structure with debris cage.

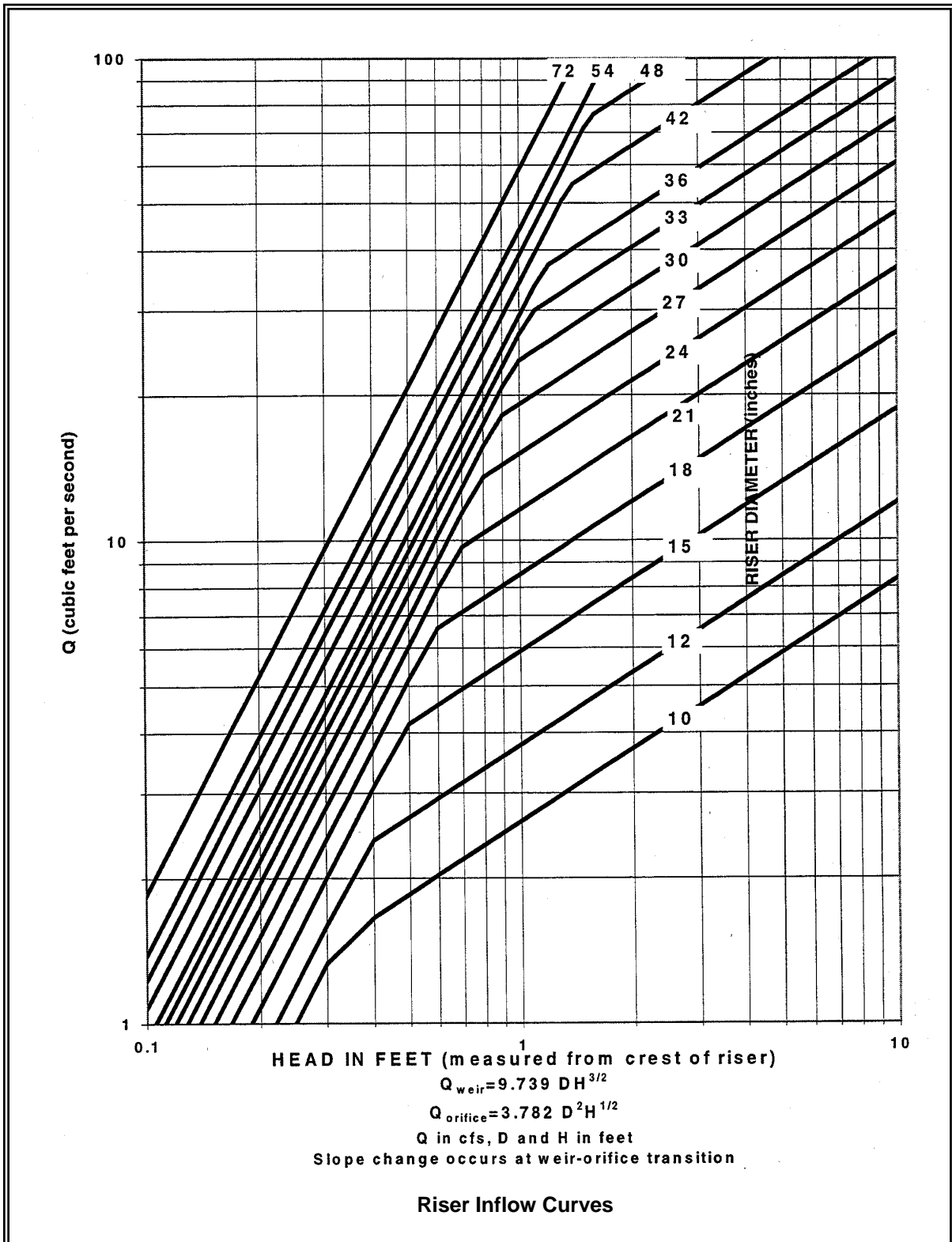

Figure FC.03.5. Overflow structure sizing.

Riser and Weir Restrictor

- Properly designed weirs may be used as flow restrictors. However, they must be designed to provide for primary overflow of the developed 100-year peak flow discharging to the detention facility.
- The combined orifice and riser (or weir) overflow may be used to meet performance requirements; however, the design must still provide for primary overflow of the developed 100-year peak flow, assuming all orifices are plugged.
- For different orifice, weir, and riser configurations and design equations and assumptions, see the MGSFlood or Western Washington Highways Hydrology Analysis Model (WHAM) training manuals:
☞ www.wsdot.wa.gov/Design/Hydraulics

Emergency Overflow Spillway

In addition to the overflow provisions described above, detention ponds must have an emergency overflow spillway. For impoundments of 10 acre-feet or greater, the emergency overflow spillway must meet the state's dam safety requirements (see discussion on dam safety later in this section). For impoundments with less than 10 acre-feet of storage, ponds must have an emergency overflow spillway that is sized to pass the 100-year postdeveloped undetained peak flow in the event of total control structure failure (for example, blockage of the control structure outlet pipe) or extreme inflows. Emergency overflow spillways are intended to control the location where flows overtop the pond perimeter and direct overflows into the downstream conveyance system or other acceptable discharge point. The bottom of the emergency overflow spillway must be set at the design water surface elevation.

Emergency overflow spillways must be provided for ponds with constructed berms more than 2 feet high or for ponds located on grades more than 5%. As an option, emergency overflow may be provided by a Type II manhole fitted with a birdcage, as shown in Figure FC.03.4. The emergency overflow structure must be designed to pass the 100-year postdeveloped peak flow directly to the downstream conveyance system or to another acceptable discharge point. Where an emergency overflow spillway would discharge to a steep slope, consideration should be given to providing an emergency overflow structure *in addition to* the spillway.

The emergency overflow spillway must be armored with riprap that is sized in conformance with guidelines in the *Hydraulics Manual*. The spillway must be armored across its full width and also must be armored down the embankment, per Section C-C in Figure FC.03.3).

Emergency overflow spillway designs as shown in Figure FC.03.2 must be analyzed as broad-crested trapezoidal weirs using the following equation:

$$Q_{100} = C (2g)^{1/2} \left[\frac{2}{3} LH^{3/2} + \frac{8}{15} (\text{Tan } \theta) H^{5/2} \right] \quad (\text{FC.03-11})$$

- where: Q_{100} = peak flow for the 100-year runoff event (cfs)
 C = discharge coefficient (0.6)
 g = gravity (32.2 ft/sec²)
 L = length of weir (ft)
 H = height of water over weir (ft)
 θ = angle of side slopes

Assuming $C = 0.6$ and $\text{Tan } \theta = 3$ (for 3H:1V slopes), the equation becomes:

$$Q_{100} = 3.21[LH^{3/2} + 2.4 H^{5/2}] \quad (\text{FC.03-12})$$

To find the width L for the weir section, the equation is rearranged to use the computed Q_{100} and trial values of H (0.2 feet minimum):

$$L = [Q_{100}/(3.21H^{3/2})] - 2.4 H \text{ or } 6 \text{ feet minimum} \quad (\text{FC.03-13})$$

Emergency overflow spillway designs using a Type II manhole fitted with a birdcage, as shown in Figure FC.03.4, must be analyzed using Figure FC.03.5 to pass the 100-year postdeveloped undetained peak flow.

Structural Design Considerations

Geometry

Pond inflows must enter through a conveyance system separate from the outlet control structure and outflow conveyance system. Maximizing distance between the inlet and outlet is encouraged to promote sediment trapping.

Pond bottoms must be level and a minimum of 0.5 feet below the outlet invert elevation to provide sediment storage.

Berms, Baffles, and Slopes

- Interior side slopes up to the emergency overflow water surface should not be steeper than 3H:1V unless a fence is provided (see *Fencing* below).
- Exterior side slopes must not be steeper than 2H:1V unless analyzed for stability by a geotechnical engineer.
- Pond walls may be vertical retaining walls subject to the following:
 - They are constructed of minimum 3000-psi structural reinforced concrete.
 - All construction joints must be provided with water stops.

- Cast-in-place wall sections must be designed as retaining walls. A licensed civil engineer with structural expertise must stamp structural designs for cast-in-place walls.
- Walls must be placed on stable, well-consolidated native material with suitable bedding, per the *Standard Specifications*. Walls must not be placed in fill slopes unless the slopes have been analyzed in a geotechnical report for stability and constructibility.
- A fence is provided along the top of the wall.
- Although the entire pond perimeter may be retaining walls, it is recommended that at least 25% of the pond perimeter be a vegetated soil slope not steeper than 7H:1V. Steeper slopes are permitted; consult with the local maintenance office.
- The designer discusses the design of the pond with the local maintenance office to determine whether there are maintenance access issues.
- The design is stamped by a licensed civil engineer with structural expertise.
- Other retaining walls such as rockeries, concrete, masonry unit walls, and keystone-type walls may be used if designed under the direction of a geotechnical engineer or a civil engineer with structural expertise. If the entire pond perimeter is to be retaining walls, ladders should be provided on the full height of the walls for safe access by maintenance staff.

Embankments

- Pond berm embankments must be constructed in accordance with Section 2-03.3(14)C, Method C, of the *Standard Specifications*.
- For berm embankments 6 feet high or less, the minimum top width should be 6 feet or as recommended by a geotechnical engineer.
- Pond berm embankments must be constructed on native consolidated soil (or adequately compacted and stable fill soils analyzed by a geotechnical engineer), and free of loose surface soil materials, roots, and other organic debris.
- Pond berm embankments greater than 4 feet high must be constructed by excavating a key trench equal to 50% of the berm embankment cross-sectional height and width unless specified otherwise by a geotechnical engineer.
- Antiseepage filter-drain diaphragms must be placed on outflow pipes in berm embankments impounding water with depths greater than 8 feet at the design water surface. Additional guidance on filter-drain diaphragms is given in

Ecology's Dam Safety Guidelines, Part IV, Dam Construction and Design
(Section 3.3B): www.ecy.wa.gov/programs/wr/dams/guide.html

Dam Safety for Detention BMPs

Stormwater detention facilities that can impound 10 acre-feet (435,600 cubic feet, or 3.26 million gallons) or more of runoff with the water level at the embankment crest are subject to state dam safety requirements, even if water storage is intermittent and infrequent (WAC 173-175-020[1]). The principal safety concern is for the downstream population at risk if the embankment or other impoundment structure should breach and allow an uncontrolled release of the pond contents. Peak flows from impoundment failures are typically much larger than the 100-year flows, which these ponds are generally designed to accommodate.

Ecology's Dam Safety Office uses consequence-dependent design levels for critical project elements. There are eight design levels with storm recurrence intervals ranging from 1 in 500 years for Design Step 1, to 1 in 1,000,000 years for Design Step 8. The specific design step for a particular project depends on the downstream population and other resources that would be at risk from a failure of the impoundment. Precipitation events more extreme than the 100-year event may be rare at any one location, but have historically occurred somewhere within Washington State every few years (on average).

With regard to the engineering design of stormwater detention facilities, the primary effect of the state's dam safety requirements is in sizing the emergency spillway to accommodate the runoff from the dam safety design storm without overtopping the impoundment structure (typically a berm or other embankment). The hydrologic computation procedures are the same as those for the original pond design, except that the computations must use more extreme precipitation values and the appropriate dam safety design storm hyetographs. This information is described in detail within guidance documents developed by and available from the Dam Safety Office (contact information is provided below). In addition to the other design requirements for stormwater detention BMPs described elsewhere in this manual, dam safety requirements should be an integral part of planning and design for stormwater detention ponds. It is most cost effective to consider these requirements at the beginning of the project.

In addition to the hydrologic and hydraulic issues related to precipitation and runoff, other dam safety requirements relate to geotechnical issues; construction inspection and documentation; dam breach analysis; inundation mapping; emergency action planning; and periodic inspections by project owners and by engineers from the Dam Safety Office. All of these requirements, plus procedural requirements for plan review, approval, and payment of construction permit fees are described in detail in guidance documents developed by and available from the Dam Safety Office.

In addition to the written guidance documents, engineers from the Dam Safety Office are available to provide technical assistance to project owners and design engineers in understanding and addressing the dam safety requirements for their specific project. In the

interest of providing a smooth integration of dam safety requirements into the stormwater detention project and streamlining the Dam Safety Office engineering review and issuance of the construction permit, it is recommended and requested that the Dam Safety Office be contacted early in the project planning process. The Dam Safety Office is located in the Ecology Headquarters building in Lacey. Electronic versions of the guidance documents are available on Ecology's website: www.ecy.wa.gov/programs/wr/dams/dss.html

Groundwater Issues

Identification and Avoidance

Flow control BMPs must be constructed above the seasonal high groundwater table. Storage capacity and proper flow attenuation are compromised if groundwater levels are allowed to fluctuate above the limits of live storage. The project should locate flow control pond, vault, and tank locations within the TDA such that there is a separation between the local groundwater table elevation and the bottom of the proposed BMP. In some cases, this may require that a much shallower pond be constructed in order to function properly.

The groundwater table elevation in and around the flow control facility needs to be determined early in the project. This can be done by installing piezometers at the BMP location and taking water table readings over at least one wet season. The wet season is generally defined as October 1 through April 30. Where it has been determined that site conditions within the project limits are not conducive to constructing flow control facilities due to high groundwater levels, it may be necessary to evaluate potential project impacts and solutions using the EEF Checklist in Appendix 2A or by following the *demonstrative approach* discussed in Section 1-1.3. Designers should look for opportunities to provide flow control to an equivalent area in the project that discharges to the same sensitive area or receiving water body.

Seeps and Springs

Intermittent seeps along cut slopes are typically fed by a shallow groundwater source (interflow) flowing along a relatively impermeable soil stratum. These flows are storm-driven and should discontinue after a few weeks of dry weather. However, if the site exhibits other more continuous seeps and springs extending through longer dry periods, they are likely from a deeper groundwater source. When continuous flows are intercepted and directed through flow control facilities, adjustments to the facility design may have to be made to account for the additional base flow (unless already considered in the design).

Site Design Elements

Setback Requirements

Detention ponds must be a minimum of 5 feet from any property line or vegetative buffer. This distance may need to be increased based on the permit requirements of the local jurisdiction.

Detention ponds must be 100 feet from any septic tank or drain field (except wet vaults, which must be a minimum of 20 feet).

The designer should request from the WSDOT Materials Lab a geotechnical report for the project that evaluates any potential structural site instability due to extended subgrade saturation or head loading of the permeable layer, including the potential impacts to downgradient properties—especially on hills with known side-hill seeps. The report should address the adequacy of the proposed detention pond locations and recommend the necessary setbacks from any steep slopes and building foundations.

Landscaping (Planting Considerations)

The project should revegetate the side slopes of the flow control pond to the maximum extent practicable. The minimum vegetation effort would be to hydroseed the pond's interior above the 100-year water surface elevation and the exterior side slopes before completion of the project.

Fencing

Pond walls may be retaining walls as long as a fence is provided along the top of the wall and at least 25% of the pond perimeter will have a slope of 3H:1V or flatter. (See the *Design Manual* for additional fencing requirements.)

Signage

The local jurisdiction may require that the detention pond have a sign. The sign should be placed for maximum visibility from adjacent streets, sidewalks, and paths. (See the Region or HQ Hydraulics Office for signage specifications.)

General Maintenance Requirements

For general maintenance requirements, see Section 5-3.6.1.

5-4.3 Stormwater Facility Components

5-4.3.1 Pretreatment

RT.24 – Presettling/Sedimentation Basin

Introduction

General Description

A *presettling basin* provides pretreatment of runoff to remove suspended solids that can impact other primary runoff treatment BMPs (see Figures RT.24.1 and RT.24.2).

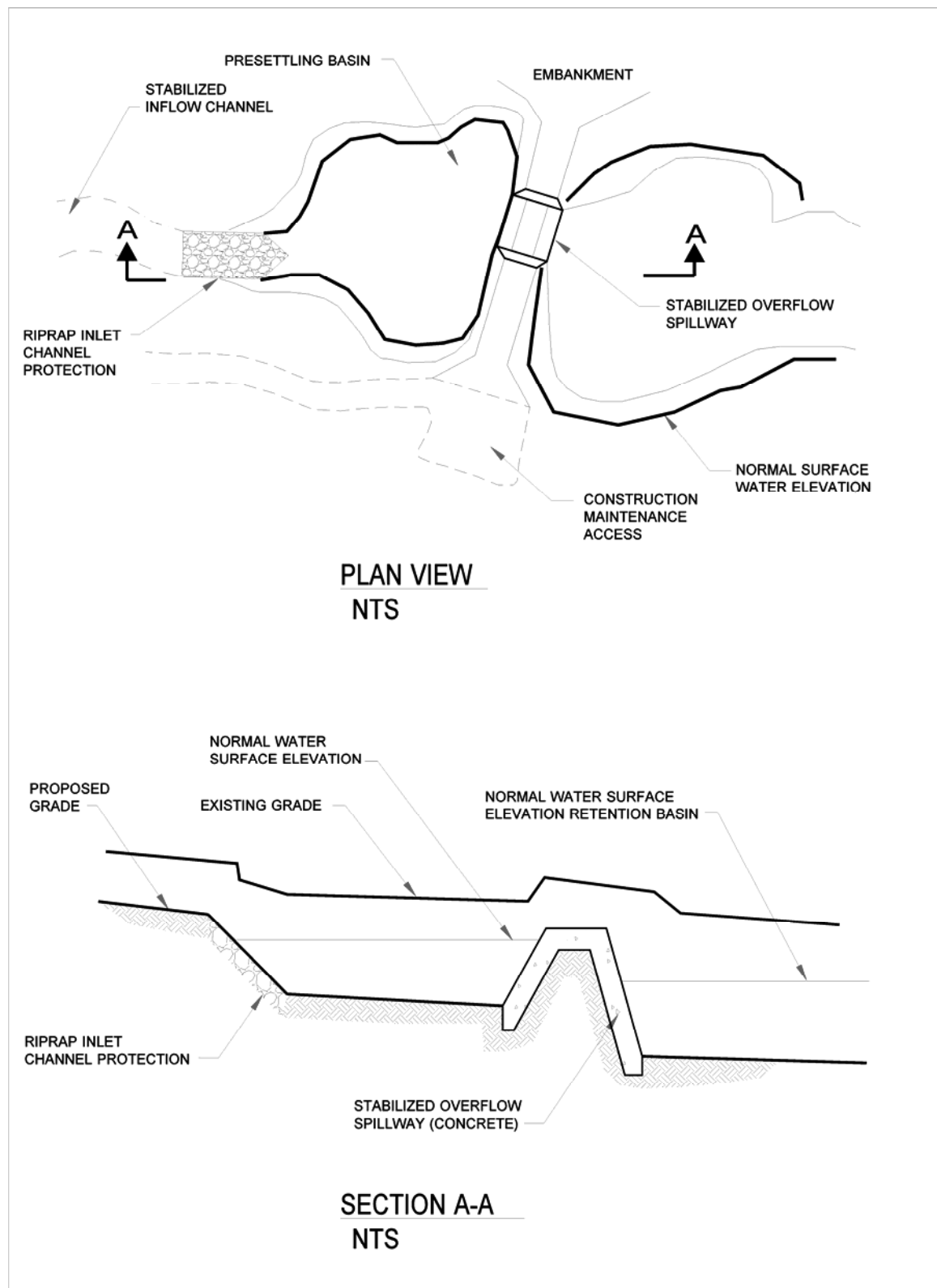

Figure RT.24.1. Typical presettling/sedimentation basin.

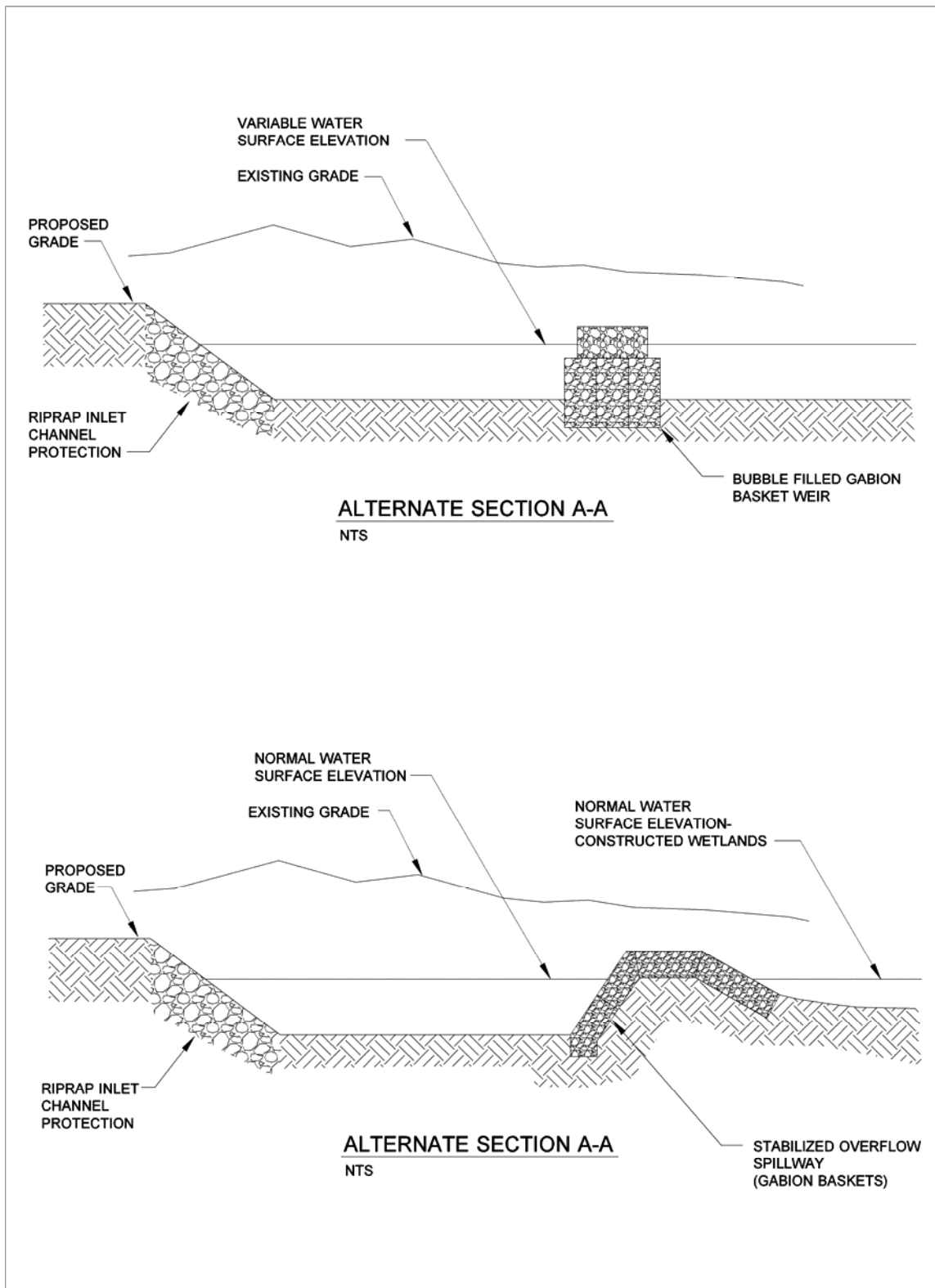

Figure RT.24.2. Presettling/sedimentation basin: Alternate sections.

Applications and Limitations

The most attractive aspect of a presettling basin is its isolation from the rest of the facility. Presettling basins allow sediment to fall out of suspension. However, they do not detain water long enough for removal of most pollutants (such as some metals). Presettling basins are used frequently as pretreatment for downstream infiltration facilities and to protect more sensitive facilities (such as constructed stormwater treatment wetlands) from excessive sediment loads. Runoff treated by a presettling basin may not be discharged directly to a receiving water body; it must be further treated by a basic or enhanced runoff treatment BMP.

Design Flow Elements

Flows to Be Treated

A presettling basin should be designed with a wet pool. The runoff treatment volume must be at least 30% of the total volume of runoff from the 6-month, 24-hour storm event.

Overflow or Bypass

Presettling basin design must take into consideration the possibility of overflows. A designed overflow section should be constructed along the presettling basin embankment to allow flows to exit at a nonerosive velocity during the 6-month, 24-hour storm event. The overflow may be set at the permanent pool level. The use of an aquatic bench with emergent vegetation around the perimeter helps with water quality.

Inlet Structure

The runoff treatment volume should be discharged uniformly and at low velocity into the presettling basin to maintain near-quiescent conditions, which are necessary for effective treatment. It is desirable for the heavier suspended material to drop out near the front of the basin. Energy-dissipation devices may be necessary to reduce inlet velocities that exceed 3 feet per second.

Outlet Control Structure

The outlet structure conveys the runoff treatment volume from the presettling basin to the primary treatment BMP (for example, a wetland or sand filtration basin). The passive outlet control structure can be created as an earthen berm, gabion, concrete, or riprap wall along the separation embankment preceding the primary treatment BMP.

Structure Design Considerations

Geometry

A long, narrow basin is preferred because it is less prone to short-circuiting and tends to maximize available treatment area. The length-to-width ratio should be at least 3:1 and preferably 5:1. The inlet and outlet should be at opposite ends of the basin, where feasible.

Materials

Widely acceptable construction materials and specifications, such as those developed by the USDA National Resources Conservation Service (NRCS) or the U.S. Army Corps of Engineers for embankment ponds and reservoirs, may aid in building the impoundment.

Berms, Embankments, Baffles, and Slopes

Berm embankments must be constructed on native consolidated soil (or adequately compacted and stable fill soils analyzed by a geotechnical report) free of loose surface soil materials, roots, and other organic debris.

The inlet and outlet should be at opposite ends of the basin where feasible. If this is not possible, then baffles can be installed to increase the flow path and water residence time.

Exposed earth on the side slopes and bottom should be sodded or seeded with the appropriate seed mixture as soon as is practicable. If necessary, geotextile or matting may be used to stabilize slopes until seeding or sodding become established.

If composed of a structural retaining wall, interior side slopes may be nearly vertical as long as maintenance access is provided. Otherwise, they should be no steeper than 3H:1V. Exterior embankment slopes should be 2H:1V or less. The bottom of the basin should have a 2% slope to allow complete drainage. The minimum depth must be 4 feet; the maximum depth must be 6 feet.

Embankments that impound water must comply with Washington dam safety regulations (WAC 173-175). If the impoundment has a storage capacity (including both water and sediment storage volumes) greater than 10 acre-feet (435,000 cubic feet, or 3.26 million gallons) above natural ground level, then a dam safety design and review are required.

Liners

If the basin intercepts the seasonal high groundwater table, a liner is recommended. In these situations, a low-permeability liner or treatment liner must cover the bottom and side areas. (See liner criteria in Section 5-4.3.3 for further information.)

Site Design Elements

Setback Requirements

- Presettling basins must be a minimum of 5 feet from any property line or vegetative buffer. This distance may need to be increased based on the permit requirements of the local jurisdiction.
- Presettling basins must be 100 feet from any septic tank or drain field, except wet vaults, which must be a minimum of 20 feet.

- The designer should request from the WSDOT Materials Lab a geotechnical report for the project that evaluates any potential structural site instability due to extended subgrade saturation or head loading of the permeable layer, including the potential impacts to downgradient properties (especially on hills with known side-hill seeps). The report should address the adequacy of the proposed presettling basin locations and recommend the necessary setbacks from any steep slopes and building foundations.

Safety, Signage, and Fencing

Basins that are readily accessible to populated areas should incorporate all possible safety precautions. Dangerous outlet facilities should be protected by enclosure. Warning signs should be used wherever appropriate. Signs should be placed so that at least one is clearly visible and legible from all adjacent streets, sidewalks, or paths.

Maintenance

Failure of large impoundment structures can cause significant property damage and even loss of life. Impoundment structures should be regularly inspected for signs of failure, such as seepage or cracks in the walls or berm.

Presettling basins are less likely than wet ponds to build up excessive levels of heavy metals from sediments washed off impervious areas. Routine maintenance should remove and properly dispose of any significant sediment deposits. Sediment should be removed every three to five years or when 6 to 12 inches have accumulated, whichever comes first. More frequent removal of sediment from the presettling basin may be less costly over the same time period than a one-time cleaning of the entire basin. (See Section 5-5 for further criteria.)

5-4.3.2 Soil Amendments

Introduction

General Description

Soil amendments, including compost and other organic materials, help restore the health of the soil and increase environmental functions such as rainwater infiltration and natural detention, evapotranspiration, and plant health. Soil amendments can help prevent or minimize adverse stormwater impacts during construction and are used along with vegetation as a permanent runoff treatment BMP. Compost is a versatile material that can be used as a component in many other permanent and temporary stormwater BMPs.

Compost-amended soils can be modeled as pasture on native soil. The final organic content of these soils should be 10% for all areas, excluding turf areas, which are expected to receive a high amount of foot traffic. Turf (lawn) areas with high foot traffic must have a 5% final organic content.

Applications and Limitations

Soil amendments can be used in most unpaved areas within the project. If soil amendments are applied as a blanket, they perform erosion control functions immediately by providing a cover to bare soils. When incorporated into the soil, they increase infiltration and adsorption of metals and aid in the uptake of nutrients. They also enhance vegetation growth and plant establishment.

Compost provides an excellent growing medium for roadside vegetation. Traditional highway construction methods typically result in the excavation and removal of the area's topsoil. Roadway embankments are then constructed from material that has few nutrients, is low in organic material, and is compacted to 95% maximum density. Adding compost to roadway slopes and ditches provides soil cover, improves soil fertility and texture, and greatly improves the vegetative growth and soil stability (thereby reducing erosion).

Organic soil amendments soak up water like a sponge and store it until it can be slowly infiltrated into the ground or taken up by plants. (For instance, 4 inches of compost tilled into 8 inches of Alderwood series soil increased the water storage capacity by 100% [Harrison et al., 1997].) In some BMP applications, the volume of compost can be sized to absorb and hold the runoff treatment storm.

Compost is an excellent filtration medium, which provides treatment for highway runoff. Compost has a high cation exchange capacity (CEC) that chemically traps dissolved heavy metals and binds them to the compost material. Oils, grease, and floatables are also removed from stormwater as it is filtered through the compost.

Compost is very absorbent when dry, but when saturated it has a high infiltration rate. Therefore, greater storm events can pass through compost medium without hindering the infiltration rates of underlying soils or drain materials. Compost has also been shown to improve the infiltration rates of underlying soils, even till soils.

Placement of a compost blanket on bare soil helps stabilize the soil and prevent surface erosion by intercepting rainfall. This type of application changes the texture and workability of the soil, lengthens the acceptable seeding windows, and encourages plant growth.

Compost soil amendments can be used in the construction phase of projects as compost berms and compost socks in lieu of conventional geotextile silt fences for sediment control (see BMP 30, Filter Berm, in Appendix 6A). While being an effective sediment trap during the construction phase, compost berms are advantageous in that they can be bladed out at the construction site, which avoids bid items for the haul and disposal of silt fences. If the permanent stormwater design involves use of compost-amended vegetated filter strips, a batch of compost can be used as sediment control in a berm, then the berm can be bladed out along a highway roadside, where it can be used as part of vegetated filter strip construction. Compost socks can be left in place and will deteriorate with time. For information on compost sock use, limitations, and placement, contact the Region Hydraulics Office, the HQ Roadside and Site Development Section, or the HQ Environmental Services Office.

Maintenance

Compost, as with sand filters or other filter mediums, can become plugged with fines and sediment, which may require removal and replacement. Including vegetation with compost helps prevent the medium from becoming plugged with sediment by breaking up the sediment and creating root pathways for stormwater to penetrate into the compost. It is expected that soil amendments will have a removal and replacement cycle; however, this time frame has not yet been established.

Structural Design Considerations

Materials

Compost material must be aged and cured according to Section 9-14.4(8) of the *Standard Specifications*.

There are two types of compost specified in the *Standard Specifications*: fine and coarse. Fine compost is a finer and usually more mature form of compost. It is for general soil amendment use and should not be used for compost filter berms or socks. Coarse compost has been screened to remove most of the fines. To prevent failure due to clogging, this type of compost is specified for compost berms and socks. Both types of compost can be used as a soil amendment or blanket depending on the soil type and desired final outcome. Consult the Region or HQ Landscape Architect or the State Horticulturist for site-specific recommendations.

Compost

Organic soil amendment, suitable for landscaping and stormwater management, should be a stable, **mature compost** derived from organic waste materials, including yard debris, manures, biosolids, wood wastes, or other organic materials that meet the intent of the organic soil amendment specification. **Compost stability** indicates the level of microbial activity in the compost and is measured by the amount of CO² produced over a given period of time by a sample in a closed container. Unstable compost can render nutrients temporarily unavailable and create objectionable odors.

Compost quality can be determined by examining the material and by qualitative tests. A simple way to judge compost quality is to smell and examine the finished product, which should have the following characteristics (WORC, 2003):

- Earthy smell that is not sour, sweet, nor ammonia-like
- Brown to black in color
- Mixed particle sizes
- Stable temperature and does not get hot when rewetted
- Crumbly texture

Qualitative tests and producer documentation should have the following specifications:

- Material must meet the definition for “composted materials” in WSDOT’s *Standard Specifications*, Section 9-14, and WAC 173-350, Section 220, which is available online: www.ecy.wa.gov/programs/swfa/facilities/350.html
- Compost used in enhanced runoff treatment applications must not contain biosolids or any street or highway sweepings

For further information, see the *Roadside Manual*, Chapter 700.

Organic Matter Content of Soil Mixes

The minimum organic matter content may be achieved by amending soils using the preapproved *Presumptive Method* (as outlined below) or by amending soils using the Custom Method, where the designer would have to calculate a custom amendment rate for the existing site soil conditions. The Presumptive Method simplifies planning and implementation; however, the organic matter content of the disturbed on-site soils may be relatively good and not require as extensive an application of amendment material. In many cases, calculating a site-specific rate using the Custom Method may result in significant savings in amendment material and application costs.

Presumptive Method for Determining Soil Organic Content

Soil amendments can be used two ways: placed on top of the soil or incorporated into it. The intent of incorporation is to increase the organic content of the soil, replicating a forested soil condition. Figure 5.4.3.1 shows typical details for soil amendments used in woody planting areas and grass or CAVFS areas.

To encourage native woody plant species, the following *presumptive* technique can be employed:

- Incorporate 3 inches of coarse compost into the top 9 inches of soil
- Place 3 inches of bark or wood chip mulch on the surface
- Plant through the layers

To encourage grass or CAVFS, the following *presumptive* technique can be employed:

- Incorporate 3 inches of coarse compost into the top 9 inches of soil
- Establish vegetation on top of incorporated soil

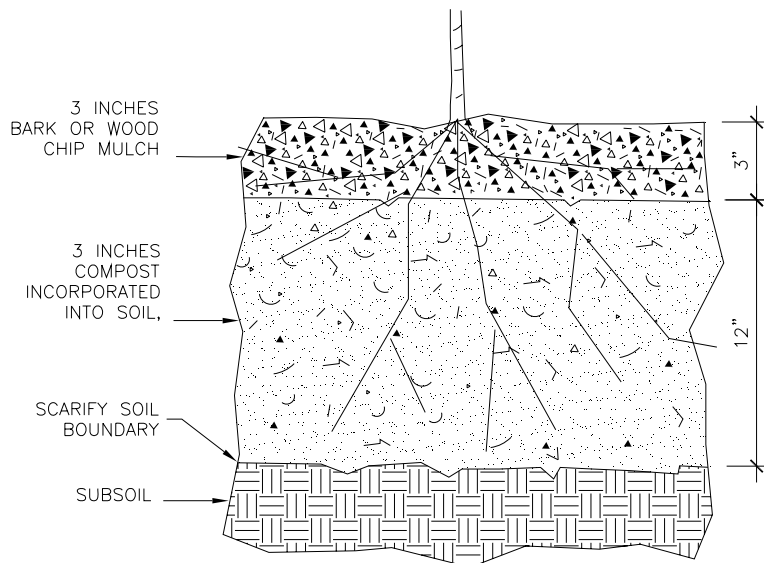

Figure A – Amendments to encourage native woody plants.

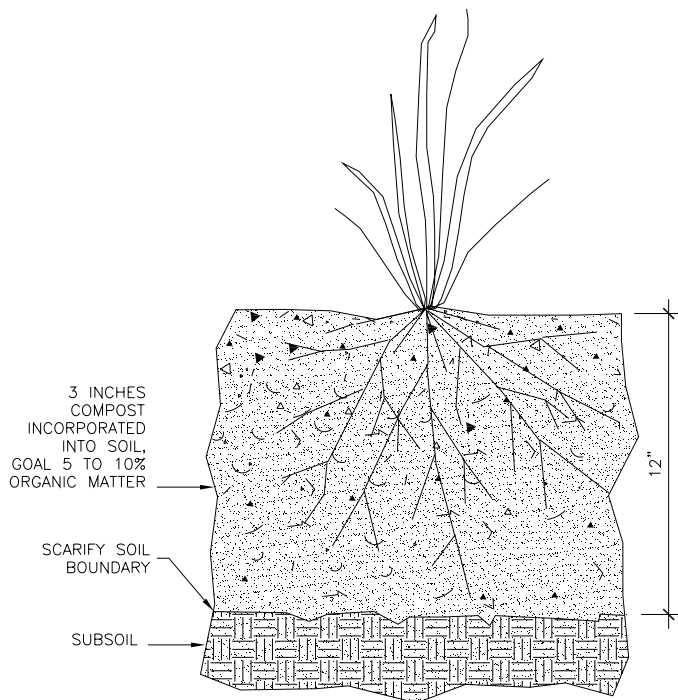

Figure B – Amendments for grass or CAVFS areas.

Figure 5.4.3.1. Soil amendments for vegetation.

The organic content of the soil should be 10% for areas planted with woody species and 5% for lawn areas after adding the amendments. (Note that WSDOT does not construct many lawn areas. Some projects in urban and semiurban areas may include lawn areas. Lawns are areas that will be mowed regularly and may contain irrigation. Roadside areas that are hydroseeded for erosion control are not considered lawn areas.) The amount of compost or other soil amendments used varies by soil type and organic matter content. If there is a good possibility that site conditions may already contain a relatively high organic content, then it may be possible to modify the presumptive technique described above and still be able to achieve the 10% organic content target. The State Horticulturist, located in the HQ Design Office, is available to determine the amount of organic material in the project soils and the amount of soil amendments needed to bring the organic matter to the percentages listed above.

The design of the final soil composition is critical to the success of the facility. Use the following guidelines to design the soil mix:

- The texture for the soil component of the LID BMP soil mix should be loamy sand (USDA Soil Textural Classification).
- The final soil mix (including compost and soil) should have a minimum long-term hydraulic conductivity of 1.0 inch/hour per ASTM Designation D 2434 (Standard Test Method for Permeability of Granular Soils) at 80% compaction per ASTM Designation D 1557 (Standard Test Method for Laboratory Compaction Characteristics of Soil Using Modified Effort) (Tackett, 2004). Infiltration rate and hydraulic conductivity are assumed to be approximately the same in a uniform mix soil.
- The final soil mixture should have a minimum organic content of 10% by dry weight per ASTM Designation D 2974 (Standard Test Method for Moisture, Ash and Organic Matter of Peat and Other Organic Soils) (Tackett, 2004). Currently, gravelly sand LID BMP soil mixtures are being developed and installed to provide adequate infiltration rates at 85% to 95% compaction. While designers anticipate good performance from this specification, the mix may be slightly less than optimal for plant growth and has not been tested long term for plant health performance.
- Achieving the above recommendations will depend on the specific soil and compost characteristics. In general, the recommendation can be achieved with 60% to 65% loamy sand mixed with 25% to 30% compost or 30% sandy loam, 30% coarse sand, and 30% compost.
- The final soil mixture should be tested by the WSDOT Materials Lab prior to installation for fertility, micronutrient analysis, and organic material content. Soil amendments per State Horticulturist recommendations (if any) should be uniformly incorporated for optimum plant establishment and early growth (Tackett, 2004).

- Clay content for the final soil mix should be less than 5%.
- Compost must not contain biosolids or any street or highway sweepings.
- The pH for the soil mix should be between 5.5 and 7.0 (Stenn, 2003). If the pH falls outside the acceptable range, it may be modified with lime to increase the pH or iron sulfate plus sulfur to lower the pH. The lime or iron sulfate must be mixed uniformly into the soil prior to use in LID areas (Low-Impact Development Center, 2004).
- Soil depth should follow the design criteria in the Roadside Manual and provide acceptable minimum pollutant attenuation and good growing conditions for selected plants.
- The soil mix should be uniform and free of stones, stumps, roots, or other similar material larger than 2 inches.
- When placing topsoil, it is important that the first lift of topsoil is mixed into the top of the existing soil. This allows the roots to penetrate the underlying soil easier and helps prevent the formation of a slip plane between the two soil layers.
- The above guidelines should provide a soil texture, an organic content, and an infiltration rate suitable to meet the SSC-7, Soil Physical and Chemical Suitability for Treatment (in Chapter 4), recommendations for designing infiltration systems. A soils report evaluating these parameters should be provided to verify the treatment capability of the soil mix.

Custom Method for Determining Soil Organic Content

Calculating a custom rate requires collecting soil samples from the area to be amended and samples from the compost material. The soil and compost are then tested for percent organic matter. Compost and topsoil producers can often supply the required information for the amendment material. A quick way to determine the approximate organic matter content of a soil mix would be to use the following rules of thumb:

- Compost is typically 40% to 50% organic matter (use 45% as an average)
- Compost weighs approximately 50% as much as loam
- A mix that is 40% compost measured by volume is roughly 20% organic matter by volume
- Compost is only 50% as dense as the soil, so the mix is approximately 10% organic matter by weight (the organic matter content in soil is determined by weighing the organic material before combustion and then weighing the ash post combustion)

Compost that is applied as a land cover must have a minimum blanket depth of 2 to 3 inches, depending on slope and soil types. Slopes steeper than 4H:1V should receive 3 inches of compost as a cover. Likewise, more erodible soils must be at the higher end of the compost application range.

Compost is not recommended for areas of concentrated flow. However, it can be used in swales or on the sides of ditches above the expected flow line.

For more information on soil amendments and applications, see Chapter 700 of the *Roadside Manual*.

5-4.3.3 Facility Liners

Liners are intended to reduce the likelihood of stormwater pollutants reaching groundwater beneath runoff treatment facilities. In addition to groundwater protection considerations, liners are sometimes used to hold water, such as for a permanent pool in a wet pond.

Treatment liners amend the soil with materials that treat stormwater before it reaches more freely draining soils. They have slow rates of infiltration, generally less than 2.4 inches per hour, but not as slow as low-permeability liners. Treatment liners may use in-place native soils or imported soils.

Low-permeability liners reduce infiltration to a very slow rate, generally less than 0.02 inches per hour. These types of liners are generally used for sites with a potential for high pollutant loading in the stormwater runoff or when it is necessary to maintain a constant pool of water for extended periods of time. Low-permeability liners may be fashioned from compacted till, clay, geomembrane, or concrete. Till liners are preferred because of their general resilience and ease of maintenance.

General Design Criteria

Table 5.4.1 shows recommendations for the type of liner generally best suited for use with various runoff treatment facilities. The intent of this table is to ensure stormwater receives the required minimum amount of runoff treatment before being allowed to infiltrate in areas of relatively permeable soils.

Liners must be evenly placed over the bottom and/or sides of the treatment area of the facility, as indicated in Table 5.4.1. Areas above the treatment volume that are required to pass flows greater than the runoff treatment flow (or volume) need not be lined. However, the lining must be extended to the top of the interior side slope and anchored if it cannot be permanently secured by other means.

Table 5.4.1. Lining types recommended for runoff treatment facilities.

Runoff Treatment Facility	Area to Be Lined	Type of Liner Recommended
RT.24 – Presettling Basin	Bottom and sides	Low-permeability liner or treatment liner; if the basin intercepts the seasonal high groundwater table, a treatment liner is recommended
RT.12 – Wet Pond, and CO.01 – Combined Wet/Detention Pond	First cell: bottom and sides to runoff treatment design water surface Second cell: bottom and sides to runoff treatment design water surface	Low-permeability liner or treatment liner; if the facility intercepts the seasonal high groundwater table, a treatment liner is recommended Treatment liner
RT.13 – Constructed Stormwater Treatment Wetland, and CO.02 – Combined Stormwater Treatment Wetland/Detention Pond	Bottom and sides: both cells	Low-permeability liner or treatment liner; if the facility intercepts the seasonal high groundwater table, a treatment liner is recommended
Treatment BMPs in underground structures	Not applicable	No liner needed

For low-permeability liners, the following criteria apply:

- Where the seasonal high groundwater elevation is likely to contact a low-permeability liner, liner buoyancy may be a concern. A low-permeability liner must not be used in this situation unless evaluated and recommended by a geotechnical engineer.
- Where grass must be planted over a low-permeability liner per the facility design, a minimum of 6 inches of good topsoil or compost-amended native soil (2 inches of compost tilled into 6 inches of native till soil) must be placed over the liner in the area to be planted; 12 inches of cover is preferred.

If a treatment liner is below the seasonal high water level, the pollutant-removal performance of the liner must be evaluated by a geotechnical or groundwater specialist and found to be as protective as if the liner were above the groundwater level.

Design Criteria for Treatment Liners

The design criteria for treatment liners are as follows:

- A 2-foot-thick layer of soil with a minimum organic content of 5% and a minimum cation exchange capacity (CEC) of 5 milliequivalents per 100 grams can be used as a treatment layer beneath a runoff treatment or detention facility.
- To demonstrate that in-place soils meet the above criteria, one sample per 1000 square feet of facility area must be tested. Each sample must be a

- composite of subsamples taken throughout the depth of the treatment layer (usually 2 to 6 feet below the proposed facility invert).
- Typically, sidewall seepage is not a concern if the seepage flows through the same stratum as the bottom of the treatment BMP. However, if the treatment soil is an engineered soil or has very low permeability, the potential to bypass the treatment soil through the sidewalls may be significant. In those cases, the treatment BMP sidewalls may be lined with at least 18 inches of treatment soil, as described above, to prevent untreated seepage. The soil thickness in the sidewalls is less than in the bottom because unsaturated flow occurs with alternating wet-dry periods.
 - Organic content is measured on a dry weight basis using ASTM D2974.
 - CEC is tested using U.S. EPA laboratory method 9081.
 - A soils testing laboratory must certify that imported soil meets the organic content and CEC criteria above and must provide this certification to the local jurisdiction.
 - Animal manure used in treatment soil layers must be sterilized because of the potential for bacterial contamination of the groundwater.

Design Criteria for Low-Permeability Liner Options

This section presents the design criteria for each of the following four low-permeability liner options: compacted till liners, clay liners, geomembrane liners, and concrete liners.

Compacted Till Liners

- Liner thickness must be 18 inches after compaction.
- Soil must be compacted to 95% minimum dry density, modified proctor method (ASTM D1557).
- A different depth and density sufficient to retard the infiltration rate to 2.4×10^{-5} inches per minute may be used instead of the above criteria.
- Soil should be placed in 6-inch lifts.
- Soils may be used that meet the gradation shown in Table 5.4.2.

Table 5.4.2. Compacted till liner gradation requirements.

Sieve Size	Percent Passing
6-inch	100
4-inch	90
#4	70–100
#200	20

Clay Liners

- Liner thickness must be 12 inches.
- Clay must be compacted to 95% minimum dry density, modified proctor method (ASTM D1557).
- A different depth and density sufficient to retard the infiltration rate to 2.4×10^{-5} inches per minute may be used instead of the above criteria.
- The slope of clay liners must be restricted to 3H:1V for all areas requiring soil cover; otherwise, the soil layer must be stabilized by another method so that soil slippage into the facility does not occur. Any alternative soil stabilization method must take maintenance access into consideration.
- Where clay liners form the sides of ponds, the interior side slope should not be steeper than 3H:1V, regardless of fencing requirements. This restriction is to ensure anyone falling into the pond may safely climb out.

Geomembrane Liners

- Geomembrane liners must be ultraviolet (UV) light resistant and have a minimum thickness of 30 mils. A thickness of 40 mils is used in areas of maintenance access or where heavy machinery must be operated over the membrane.
- Geomembranes must be bedded according to manufacturers' recommendations.
- Liners must be installed so that they can be covered with 12 inches of top dressing forming the bottom and sides of the runoff treatment facility, except for liner sand filters. Top dressing consists of 6 inches of crushed rock covered with 6 inches of native soil. The rock layer is to mark the location of the liner for future maintenance operations. As an alternative to crushed rock, 12 inches of native soil may be used if orange plastic safety fencing or another highly visible, continuous marker is embedded 6 inches above the membrane.
- If possible, liners should be of a contrasting color so that maintenance workers can easily spot any area where a liner may have become exposed.

- Geomembrane liners must not be used on slopes steeper than 5H:1V to prevent the top dressing material from slipping. Textured liners may be used on slopes up to 3H:1V upon recommendation by a geotechnical engineer that the top dressing is stable for all conditions of operation, including maintenance operations.

Concrete Liners

- Portland cement liners are allowed irrespective of facility size, and shotcrete may be used on slopes. However, specifications must be developed by a professional engineer who certifies the liner against cracking or loss of water retention ability under expected conditions of operation, including facility maintenance operations. Note: Maintenance equipment can weigh up to 80,000 pounds when fully loaded.
- Asphalt concrete may not be used for liners due to its permeability to many organic pollutants.
- If grass is to be grown over a concrete liner, slopes must be no steeper than 5H:1V to prevent the top dressing material from slipping.

5-4.3.4 Flow Splitters

Although volume-based (wet pool) runoff treatment BMPs must be designed as on-line facilities, many flow rate-based runoff treatment BMPs can be designed as either on-line or off-line. On-line systems allow flows above the runoff treatment design flow to pass through the facility at a lower pollutant-removal efficiency. However, it is sometimes desirable to restrict flows to an off-line runoff treatment facility and bypass the remaining higher flows around the BMP. This can be accomplished by splitting flows in excess of the runoff treatment design flow upstream of the facility and diverting higher flows to a bypass pipe or channel. The bypass typically enters a detention pond or the downstream receiving drainage system, depending on flow control requirements. In most cases, it is the designer's choice whether runoff treatment facilities are designed as on-line or off-line; an exception is oil/water separators, which must be designed off-line.

A crucial factor in designing flow splitters is to ensure low flows are delivered to the treatment facility up to the runoff treatment design flow rate. Above this rate, additional flows are diverted to the bypass system, with minimal increase in head at the flow splitter structure, to avoid surcharging the runoff treatment facility under high flow conditions.

Flow splitters are typically manholes or vaults with concrete baffles. In place of baffles, the splitter mechanism may be a half tee section with a solid top and an orifice in the bottom of the tee section. A full tee option may also be used, as described below in *General Design Criteria*. Two possible design options for flow splitters are shown in Figures 5.4.3.2 and 5.4.3.3. Other equivalent designs that achieve the result of splitting low flows and diverting higher flows around the facility are also acceptable.

General Design Criteria

- A flow splitter must be designed to deliver the runoff treatment design flow rate to the runoff treatment facility. For the basic sand filter, which is sized based on volume, use the runoff treatment design flow rate to design the splitter.
- The top of the weir must be located at the water surface for the design flow. Remaining flows enter the bypass line. Flows modeled using a continuous simulation model should use 15-minute time steps, if available. Otherwise, use 1-hour time steps.
- The maximum head must be minimized for flow in excess of the runoff treatment design flow. Specifically, flow to the runoff treatment facility in the 100-year event must not increase the runoff treatment design flow by more than 10%.
- Either the Figure 5.4.3.2 or the Figure 5.4.3.3 design (or an equivalent design) may be used.
- As an alternative to using the solid top plate shown in Figure 5.4.3.3, a full tee section may be used with the top of the tee at the 100-year water surface. This alternative routes emergency overflows (if the overflow pipe is plugged) through the runoff treatment facility rather than backing up in the splitter manhole.
- Special applications may require the use of a modified flow splitter. The baffle wall may be fitted with a notch and adjustable weir plate to proportion runoff volumes other than high flows.
- For ponding facilities, backwater effects must be addressed in designing the height of the standpipe in the manhole.
- Ladder or step-and-handhold access must be provided. If the weir wall is higher than 36 inches, two ladders—one on either side of the wall—must be used.

Materials

- The splitter baffle may be installed in a Type 2 manhole or vault.
- The baffle wall must be made of reinforced concrete, or another suitable material resistant to corrosion, and have a minimum 4-inch thickness. The minimum clearance between the top of the baffle wall and the bottom of the manhole cover must be 4 feet; otherwise, dual access points should be provided.

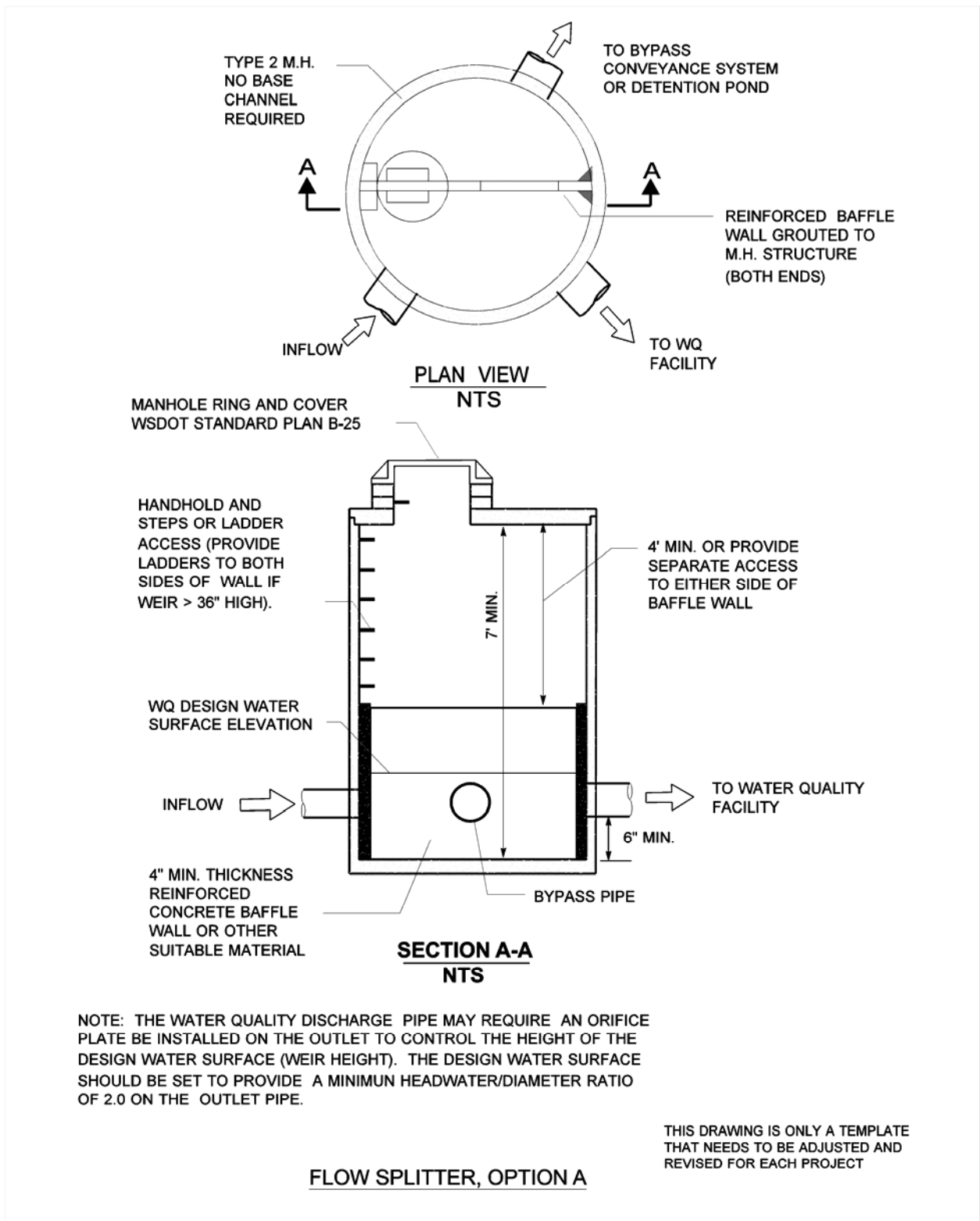

Source: King County.

Figure 5.4.3.2. Flow splitter: Option A.

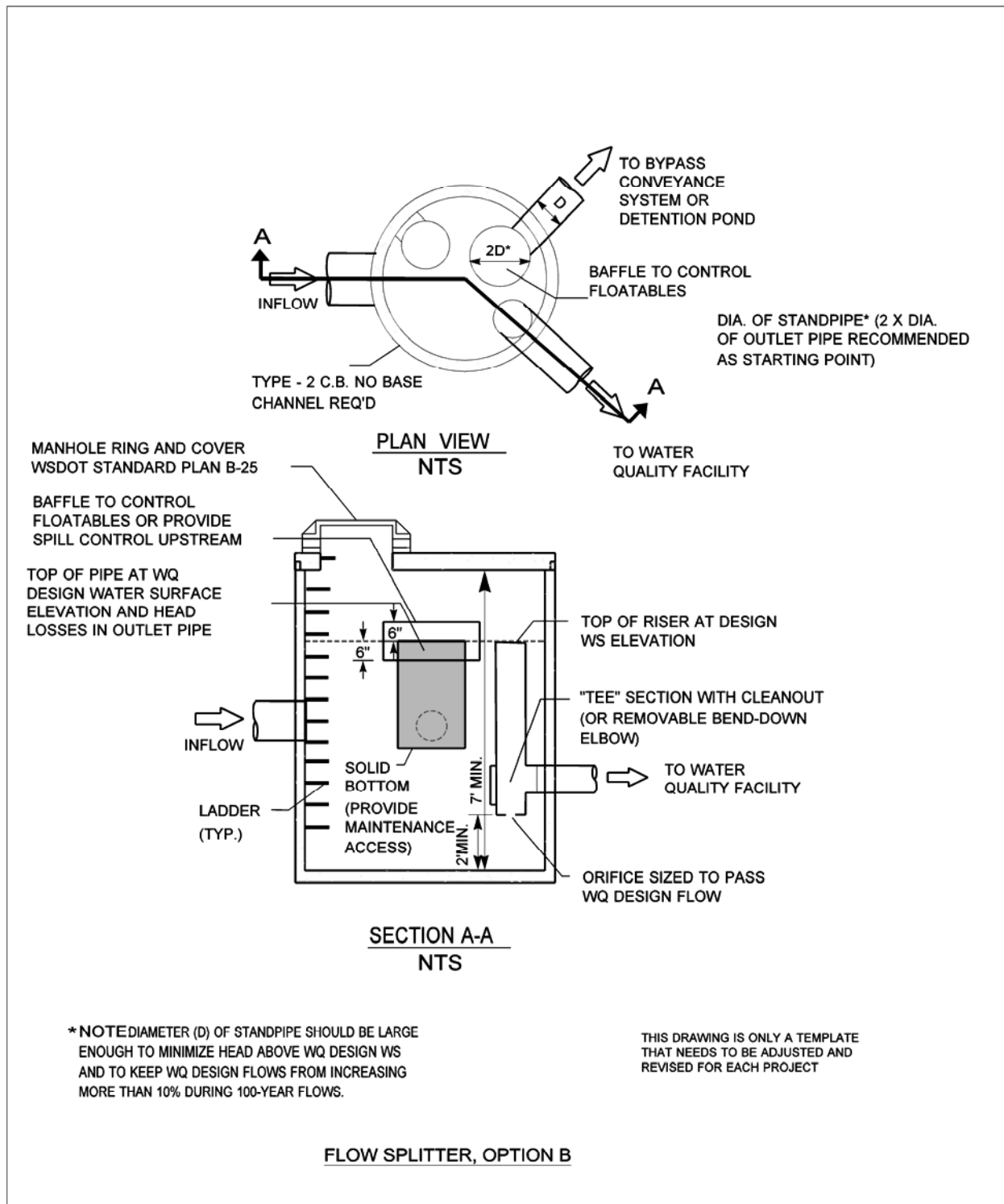

Source: King County.

Figure 5.4.3.3. Flow splitter: Option B.

- All metal parts must be corrosion resistant. Examples of preferred materials include aluminum, stainless steel, and plastic. Avoid the use of zinc and galvanized materials—because of their aquatic toxicity potential—when substitutes are available. Painting metal parts for corrosion resistance is not allowed because paint does not provide long-term protection.

5-4.3.5 Flow Spreading Options

Flow spreaders function to uniformly spread flows across the inflow portion of runoff treatment facilities (such as a sand filter, biofiltration swale, or vegetated filter strip). Five flow spreader options are presented in this section:

- Option A – Anchored plate
- Option B – Concrete sump box
- Option C – Notched curb spreader
- Option D – Through-curb ports
- Option E – Interrupted curb

Options A through C can be used for spreading flows that are concentrated. Any one of these options can be used when spreading is required by the facility design criteria. Options A through C can also be used for unconcentrated flows; in some cases they must be used, such as to correct for moderate grade changes along a vegetated filter strip.

Options D and E are only for flows that are already unconcentrated and enter a vegetated filter strip or continuous inflow biofiltration swale. Other flow spreader options are permitted with approval from the HQ Hydraulics Office.

General Design Criteria

Where flow enters the flow spreader through a pipe, it is recommended that the pipe be submerged to the extent practicable to dissipate energy as much as possible.

For higher inflows (greater than 5 cubic feet per second for the 100-year storm), a Type 1 catch basin should be positioned in the spreader, and the inflow pipe should enter the catch basin with flows exiting through the top grate. The top of the grate should be lower than the level spreader plate or, if a notched spreader is used, lower than the bottom of the V-notches.

For guidelines on outfall protection, see Section 5-4.3.6.

Option A – Anchored Plate

An anchored plate flow spreader (see Figure 5.4.3.4) must be preceded by a sump having a minimum depth of 8 inches and a minimum width of 24 inches. If not otherwise stabilized, the sump area must be lined to reduce erosion and to dissipate energy.

The top surface of the flow spreader plate must be level, projecting a minimum of 2 inches above the ground surface of the runoff treatment facility, or V-notched with notches 6 to 10 inches on center and 1 to 6 inches deep (use shallower notches with closer spacing). Alternative designs may also be used.

A flow spreader plate must extend horizontally beyond the bottom width of the facility to prevent water from eroding the side slope. The horizontal extent should protect the bank for all flows up to the 100-year flow or the maximum flow that enters the runoff treatment facility.

Flow spreader plates must be securely fixed in place.

Flow spreader plates may be made of wood, metal, fiberglass-reinforced plastic, or other durable material. If wood, pressure-treated 4-inch by 10-inch lumber/landscape timbers are acceptable.

Anchor posts must be 4-inch-square concrete, tubular stainless steel, or other material resistant to decay.

Option B – Concrete Sump Box

The wall of the downstream side of a rectangular concrete sump box (see Figure 5.4.3.5) must extend a minimum of 2 inches above the treatment bed. This serves as a weir to spread the flows uniformly across the bed.

The downstream wall of a sump box must have wing walls at both ends. Sidewalls and returns must be slightly higher than the weir so that erosion of the side slope is minimized.

Concrete for a sump box can be either cast-in-place or precast, but the bottom of the sump must be reinforced with wire mesh for cast-in-place sumps.

Sump boxes must be placed over bases consisting of 4 inches of crushed rock, $\frac{5}{8}$ -inch minus, to help ensure the sump remains level.

Option C – Notched Curb Spreader

Notched curb spreader sections (see Figure 5.4.3.6) must be made of extruded concrete laid side by side and level. Typically, five teeth per 4-foot section provides good spacing. The space between adjacent teeth forms a V-notch.

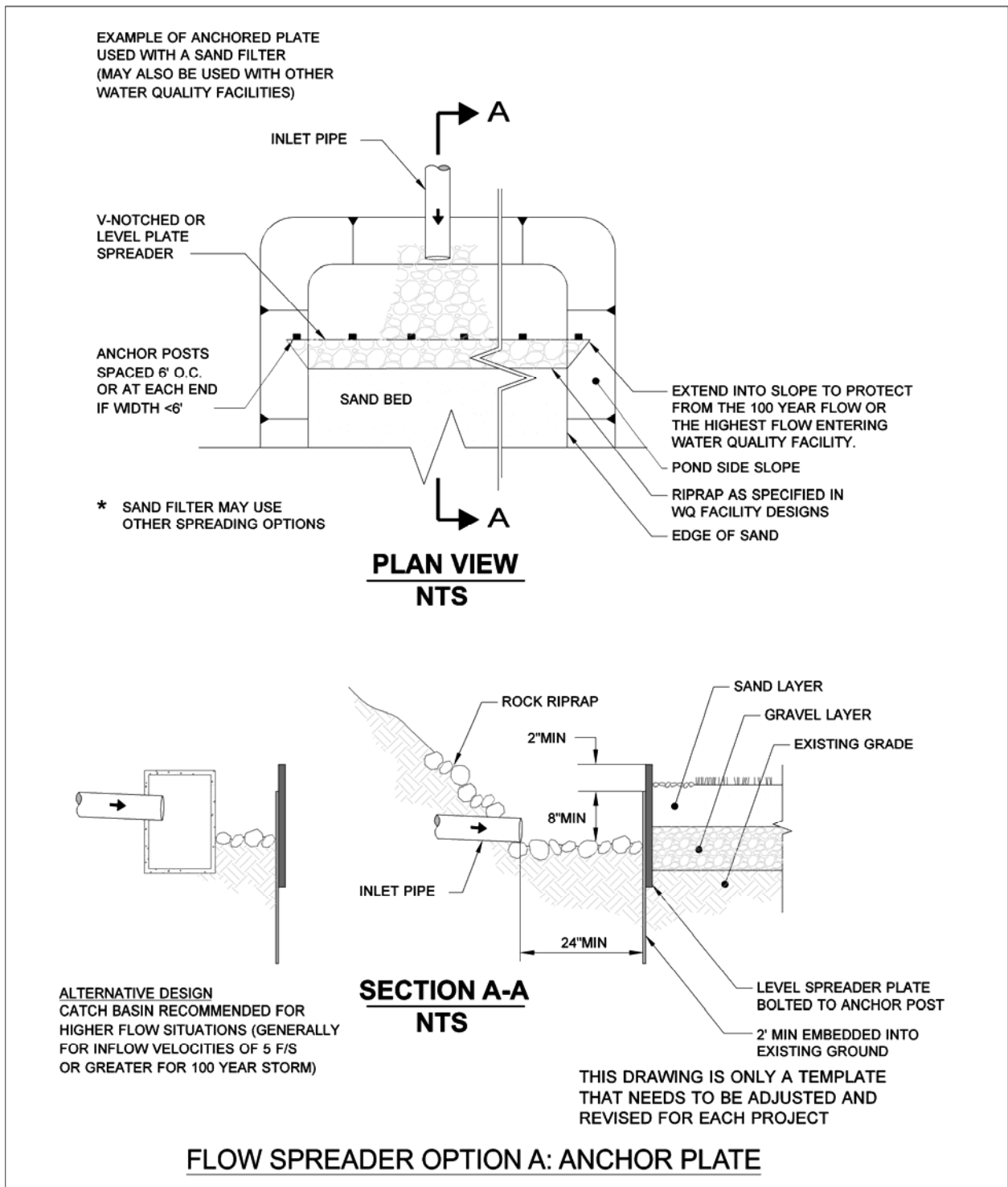

Figure 5.4.3.4. Flow spreader Option A: Anchor plate.

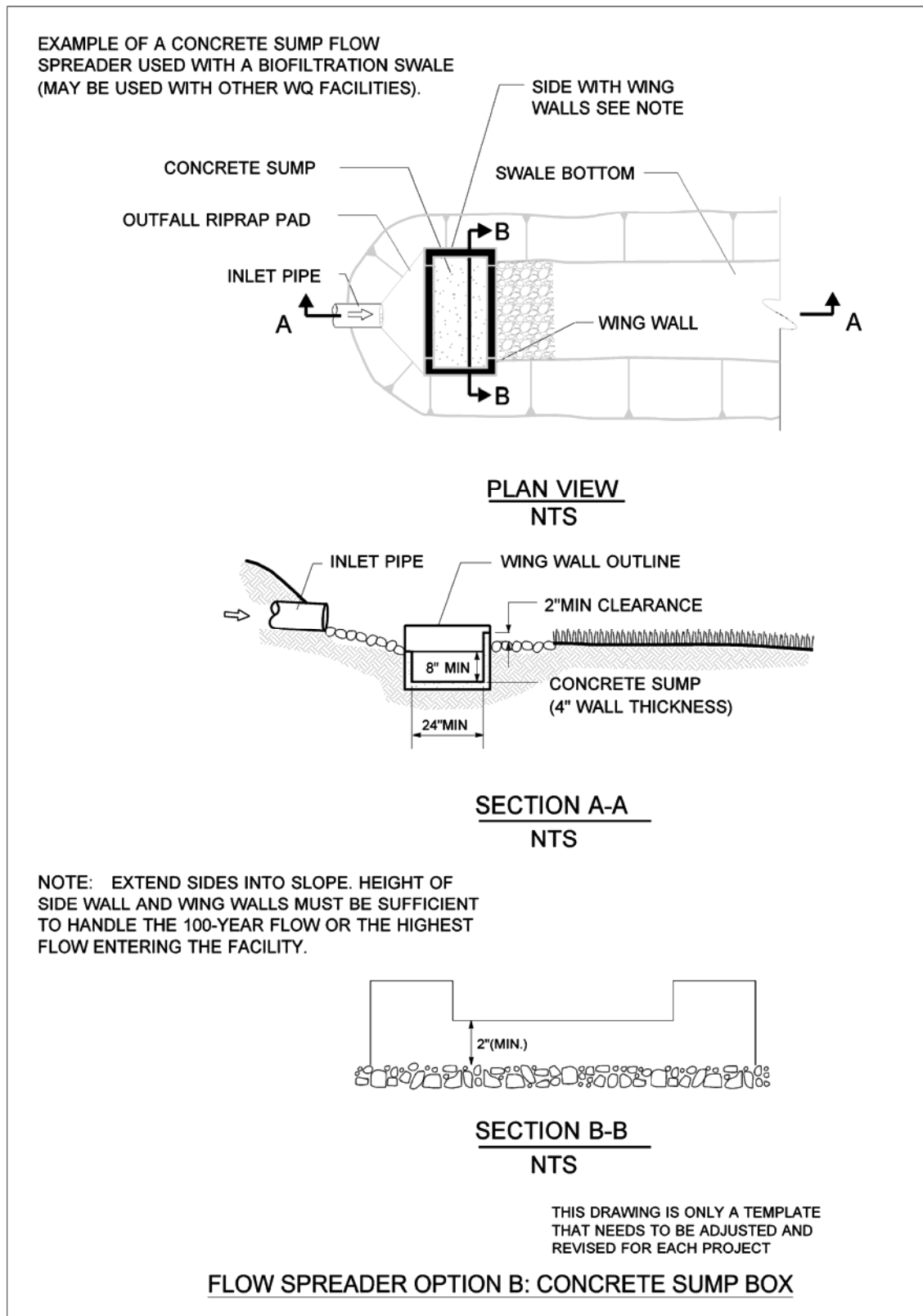

Figure 5.4.3.5. Flow spreader Option B: Concrete sump box.

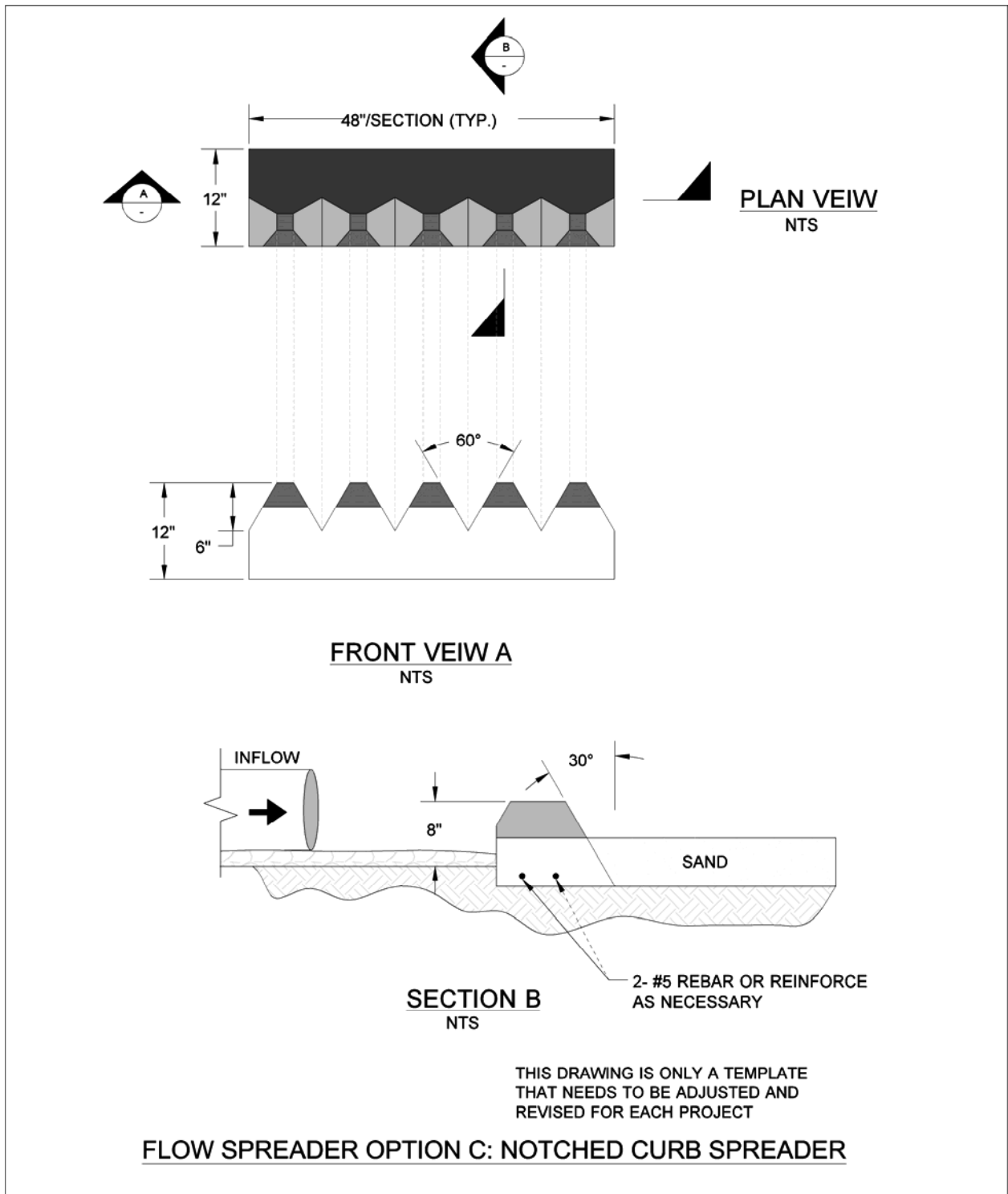

Figure 5.4.3.6. Flow spreader Option C: Notched curb spreader.

Option D – Through-Curb Ports

Unconcentrated flows from paved areas entering vegetated filter strips or continuous inflow biofiltration swales can use curb ports (see Figure 5.4.3.7) or interrupted curbs (Option E) to allow flows to enter the strip or swale. Curb ports use fabricated openings that allow concrete curbing to be poured or extruded, with an opening through the base to admit water to the runoff treatment facility.

Openings in the curb must be at regular intervals—at least every 6 feet (minimum). The width of each curb port opening must be a minimum of 11 inches. Approximately 15% or more of the curb section length should be in open ports, and no port should discharge more than about 10% of the flow.

Option E – Interrupted Curb

Interrupted curbs are sections of curb placed to have gaps spaced at regular intervals along the total width (or length, depending on the facility) of the treatment area. At a minimum, gaps must be every 6 feet to allow distribution of flows into the treatment facility before the flows become too concentrated. The opening must be a minimum of 11 inches. As a general rule, no opening should discharge more than 10% of the overall flow entering the facility.

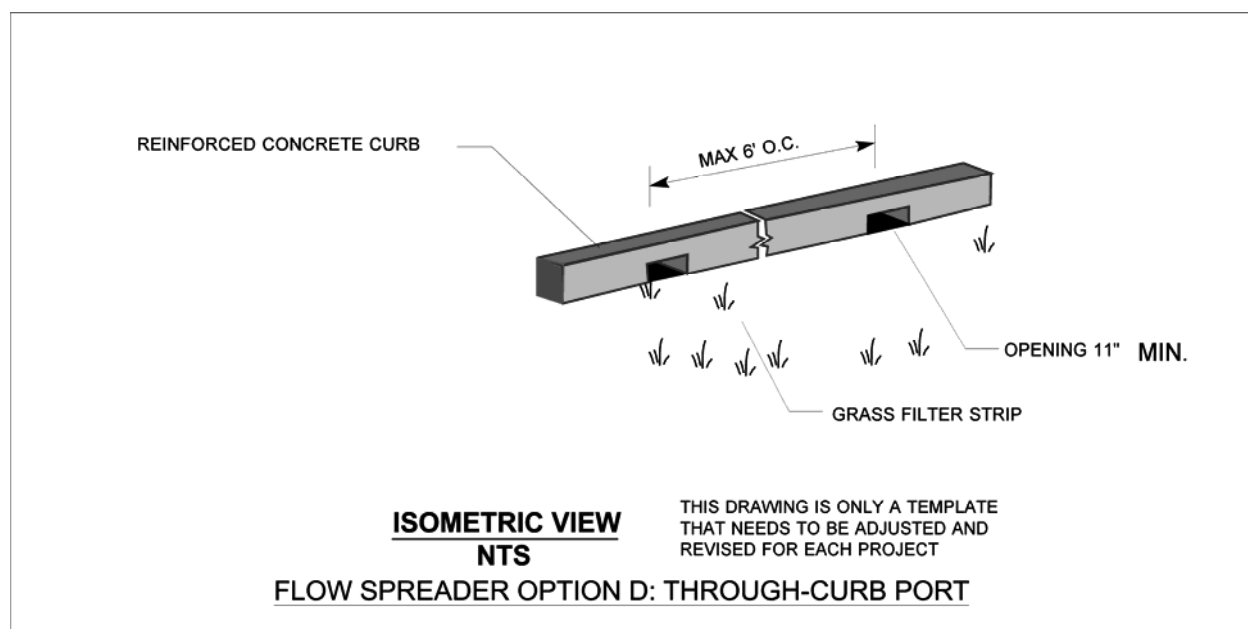

Figure 5.4.3.7. Flow spreader Option D: Through-curb port.

5-4.3.6 Outfall Systems

Properly designed outfalls are critical to reducing the chance of adverse impacts as the result of concentrated discharges from pipe systems and culverts, both on-site and downstream. Outfall systems include rock splash pads; flow dispersal trenches; gabion or other energy

dissipaters; and tight-line systems. A tight-line system is typically a continuous length of pipe used to convey flows down a steep or sensitive slope with appropriate energy dissipation at the discharge end.

General Design Criteria

Following are the general design criteria for both outfall features and tight-line systems.

Outfall Features

At a minimum, all outfalls must be provided with a rock splash pad, except as specified below and in Table 5.4.3 (see Figure 5.4.3.8).

The flow dispersal trenches shown in Figures 5.4.3.9 and 5.4.3.10 should be used only when both the following criteria are met:

- An outfall is necessary to disperse concentrated flows across uplands where no conveyance system exists and the natural (existing) discharge is unconcentrated
- The 100-year peak discharge rate is less than or equal to 0.5 cubic feet per second

For freshwater outfalls with a design velocity greater than 10 feet per second, a gabion dissipater or engineered energy dissipater may be required (see Figure 5.4.3.11). There are many possible designs.

Note: The gabion outfall detail shown in Figure 5.4.3.11 is illustrative only. A design engineered to specific site conditions must be developed.

Tight-line systems may be needed to prevent aggravation or creation of a downstream erosion problem.

In marine waters, rock splash pads and gabion structures are not recommended. Rock splash pads can be destroyed by wave action, and gabion baskets will corrode in saltwater and potentially be dislocated by wave action. Diffuser tee structures, such as the one depicted in Figure 5.4.3.12, are also not generally recommended in or above the intertidal zone. They may be acceptable in low-bank or rock shoreline locations. Stilling basins or bubble-up structures are acceptable. Generally, tight-lines should be trenched to extreme low water or else the energy of the discharge must be dissipated above the ordinary high water line. Outfalls below extreme low water may still need an energy-dissipation device (such as a tee structure) to prevent nearby erosion.

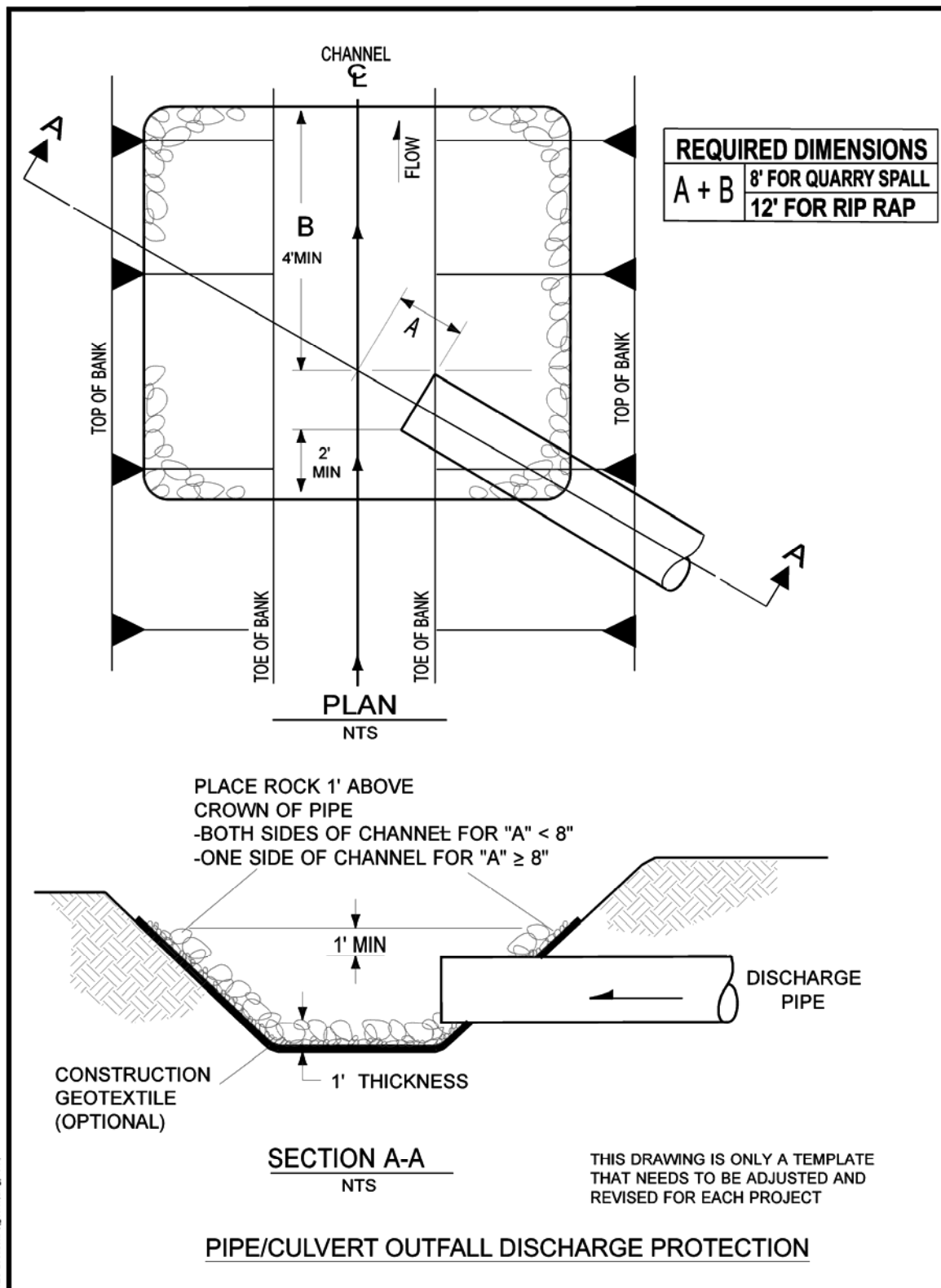

Figure 5.4.3.8. Pipe/culvert outfall discharge.

Table 5.4.3. Rock protection at outfalls.

Discharge Velocity at Design Flow (ft/sec)	Required Protection: Minimum Dimensions				
	Type	Thickness	Width	Length	Height
0 – 5	Rock lining ¹	1 foot	Diameter + 6 feet	8 feet <i>or</i> 4 x diameter, whichever is greater	Crown + 1 foot
5 ⁺ – 10	Riprap ²	2 feet	Diameter + 6 feet <i>or</i> 3 x diameter, whichever is greater	12 feet <i>or</i> 4 x diameter, whichever is greater	Crown + 1 foot
10 – 20	Gabion outfall	As required	As required	As required	Crown + 1 foot
20 ⁺	Engineered energy dissipater required				

¹ **Rock lining** must be quarry spalls with gradation as follows:

Passing 8-inch-square sieve: 100%

Passing 3-inch-square sieve: 40% to 60% maximum

Passing ¾-inch-square sieve: 0 to 10% maximum

² **Riprap** must be reasonably well-graded with gradation as follows:

Maximum stone size: 24 inches (nominal diameter)

Median stone size: 16 inches

Minimum stone size: 4 inches

Note: Riprap sizing on outlet channel is assumed to be governed by side slopes of approximately 3H:1V.

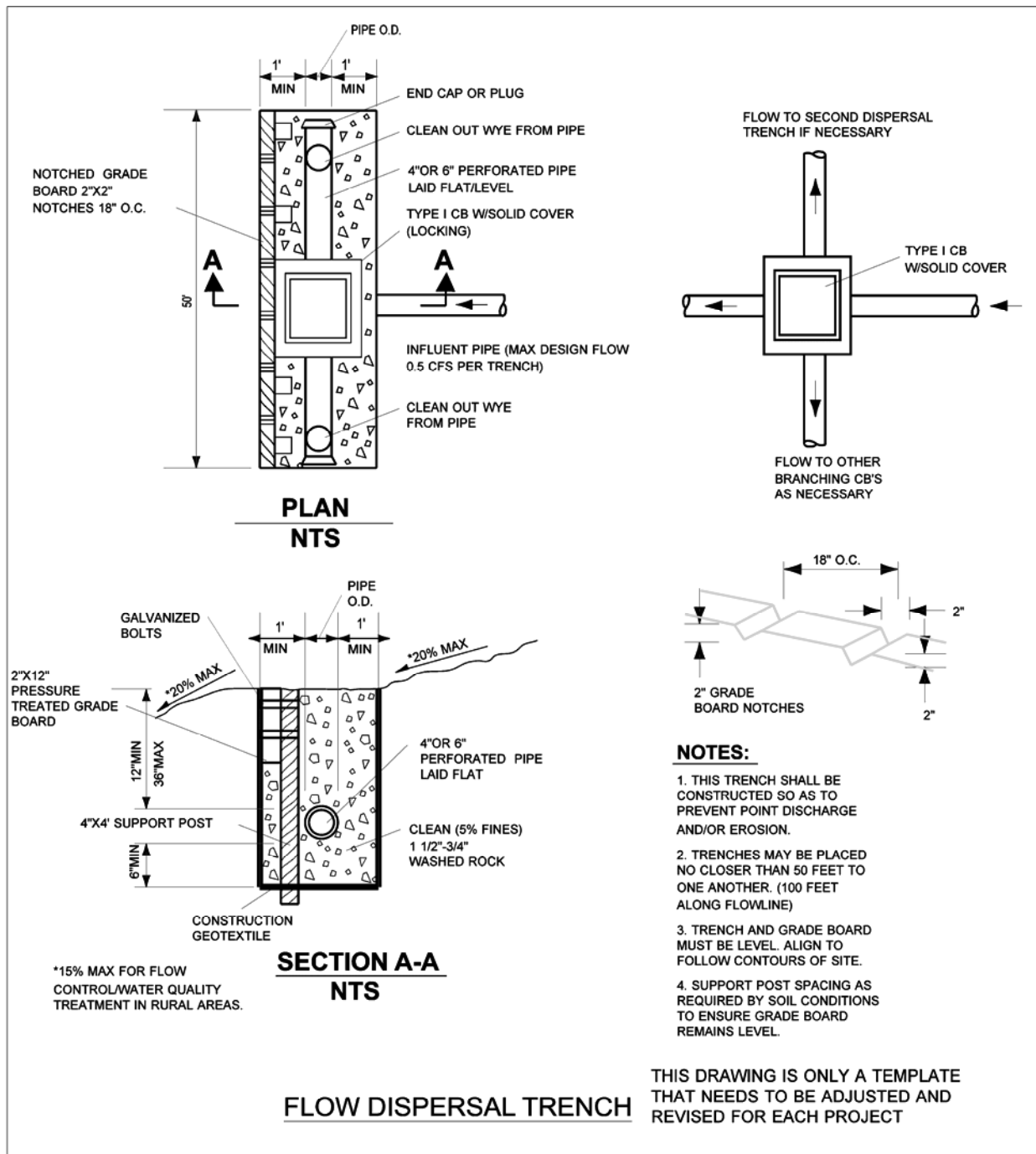

Figure 5.4.3.9. Flow dispersal trench.

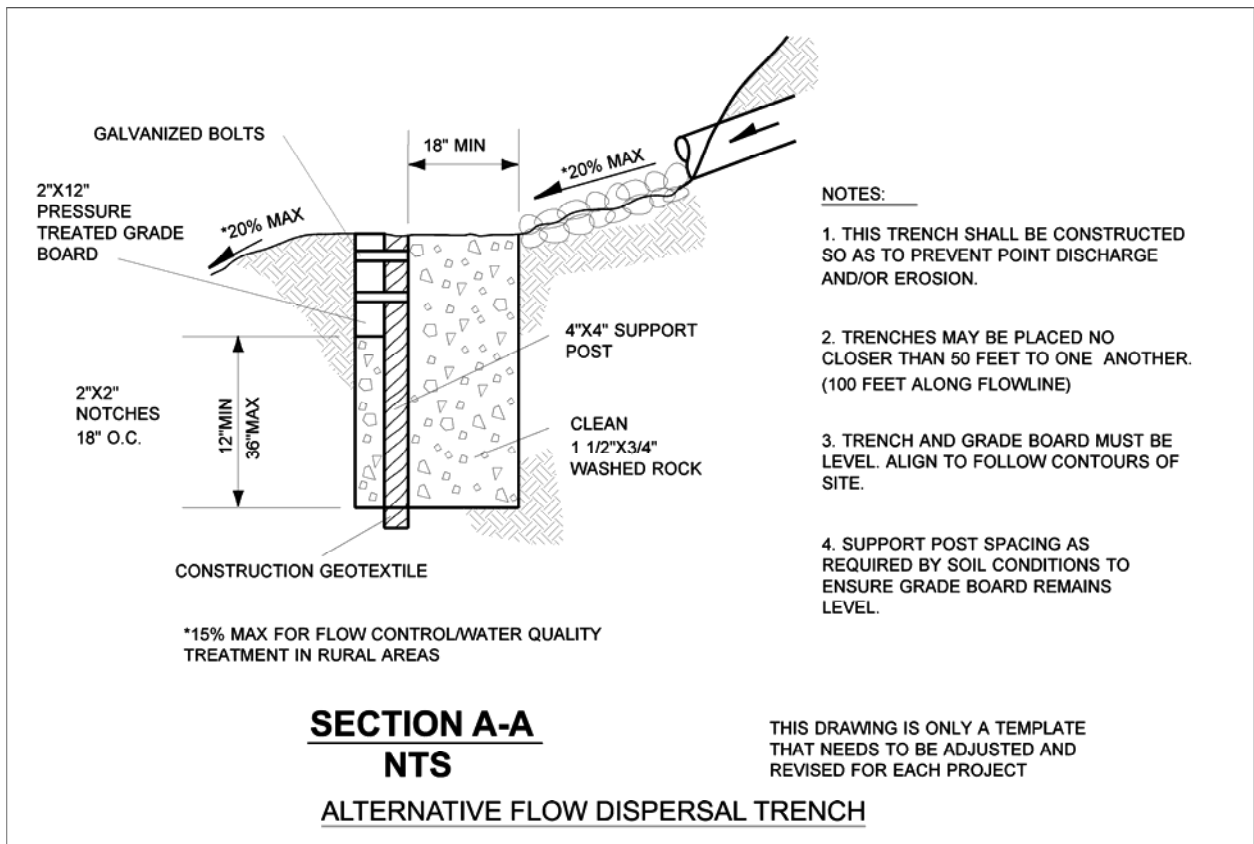

Figure 5.4.3.10. Alternative flow dispersal trench.

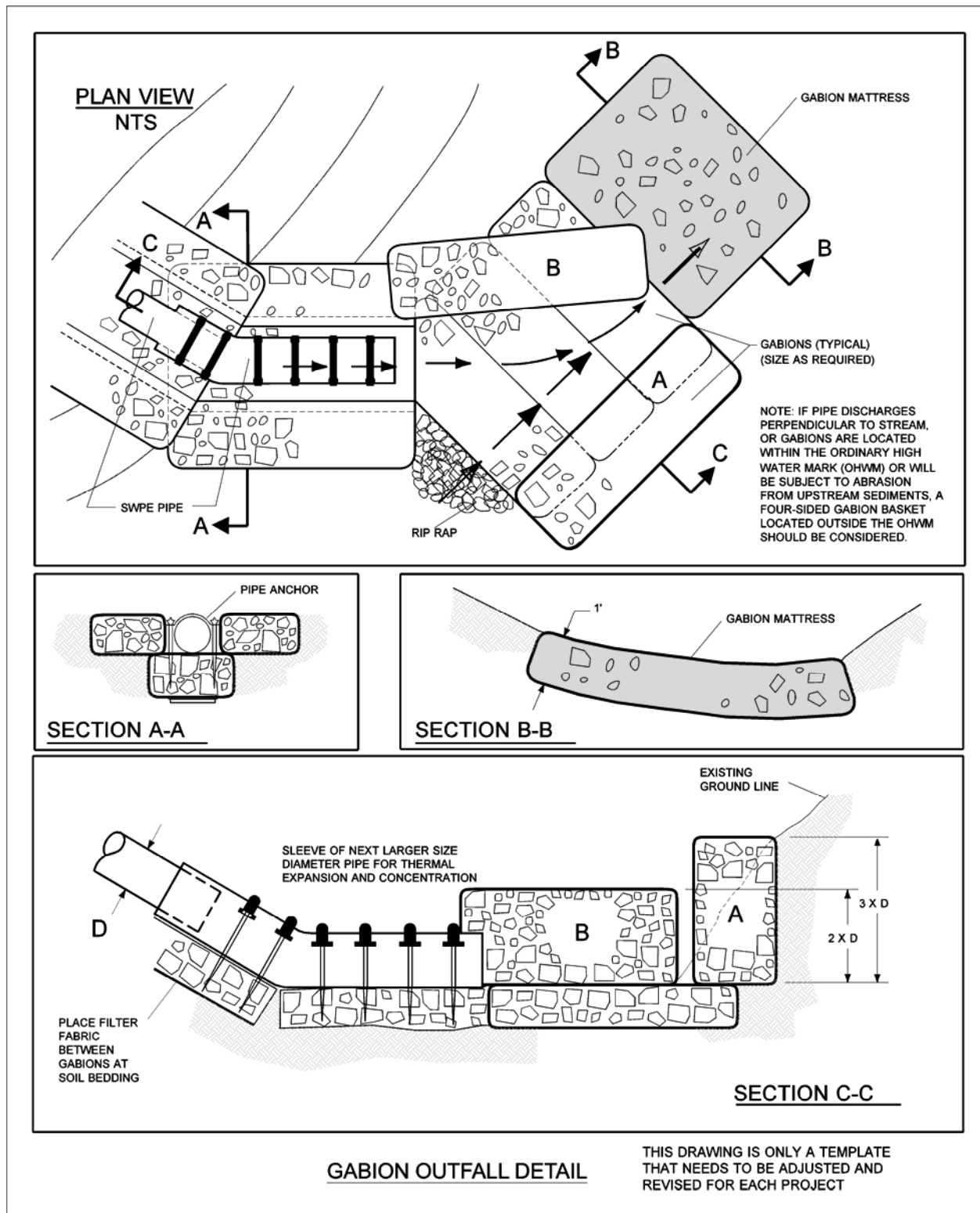

Figure 5.4.3.11. Gabion outfall detail.

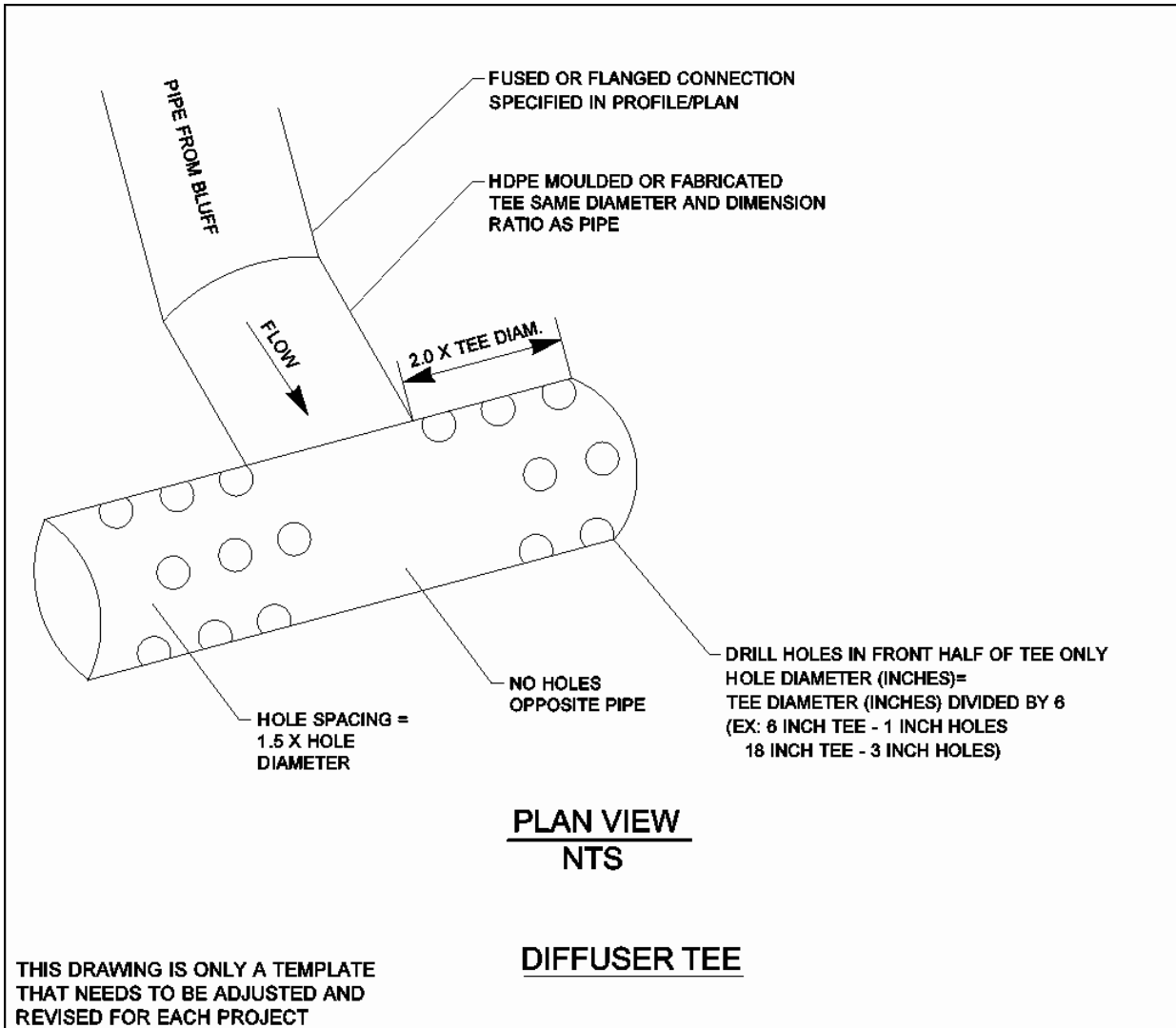

Figure 5.4.3.12. Diffuser tee: Example of energy-dissipating end feature.

Engineered energy dissipaters, including stilling basins, drop pools, hydraulic jump basins, baffled aprons, and bucket aprons, are required for outfalls with design velocity greater than 20 feet per second. These energy dissipaters should be designed using published or commonly known techniques found in such references as *Hydraulic Design of Energy Dissipaters for Culverts and Channels*, published by the Federal Highway Administration (1983); *Open Channel Flow*, by V.T. Chow (1959); *Hydraulic Design of Stilling Basins and Energy Dissipaters*, EM 25, Bureau of Reclamation (1978); and other publications such as those prepared by the Natural Resources Conservation Service (formerly the Soil Conservation Service).

Alternative mechanisms may be used, such as bubble-up structures that eventually drain and structures fitted with reinforced concrete posts. If alternative mechanisms are considered, they should be designed using sound hydraulic principles and consideration of the ease of construction and maintenance.

Tight-Line Systems

Mechanisms that reduce runoff velocity prior to discharge from an outfall are encouraged. Two of these mechanisms are drop manholes and rapid expansion of pipe diameter. Other discharge end features may be used to dissipate the discharge energy. An example of an end feature is a diffuser tee with holes in the front half, as shown in Figure 5.4.3.12.

Note: Stormwater outfalls submerged in a marine environment can be subject to plugging due to biological growth and shifting debris and sediments. Therefore, unless intensive maintenance is regularly performed, they may not meet their designed function.

New pipe outfalls can provide an opportunity for low-cost fish habitat improvements. For example, an alcove of low-velocity water can be created by constructing the pipe outfall and associated energy dissipater back from the stream edge and digging a channel, overwidened to the upstream side, from the outfall to the stream, as shown in Figure 5.4.3.13. Overwintering juvenile and migrating adult salmonids may use the alcove as shelter during high flows. Potential habitat improvements should be discussed with the Washington Department of Fish and Wildlife before inclusion in design.

Bank stabilization, bioengineering, and habitat features may be required for disturbed areas.

Outfall structures should be located where they minimize impacts to fish, shellfish, and their habitats.

One caution to note is that the in-stream gabion mattress energy dissipater may not be acceptable within the ordinary high water level of fish-bearing waters or where gabions are subject to abrasion from upstream channel sediments. A four-sided gabion basket located above the ordinary high water level should be considered for these applications.

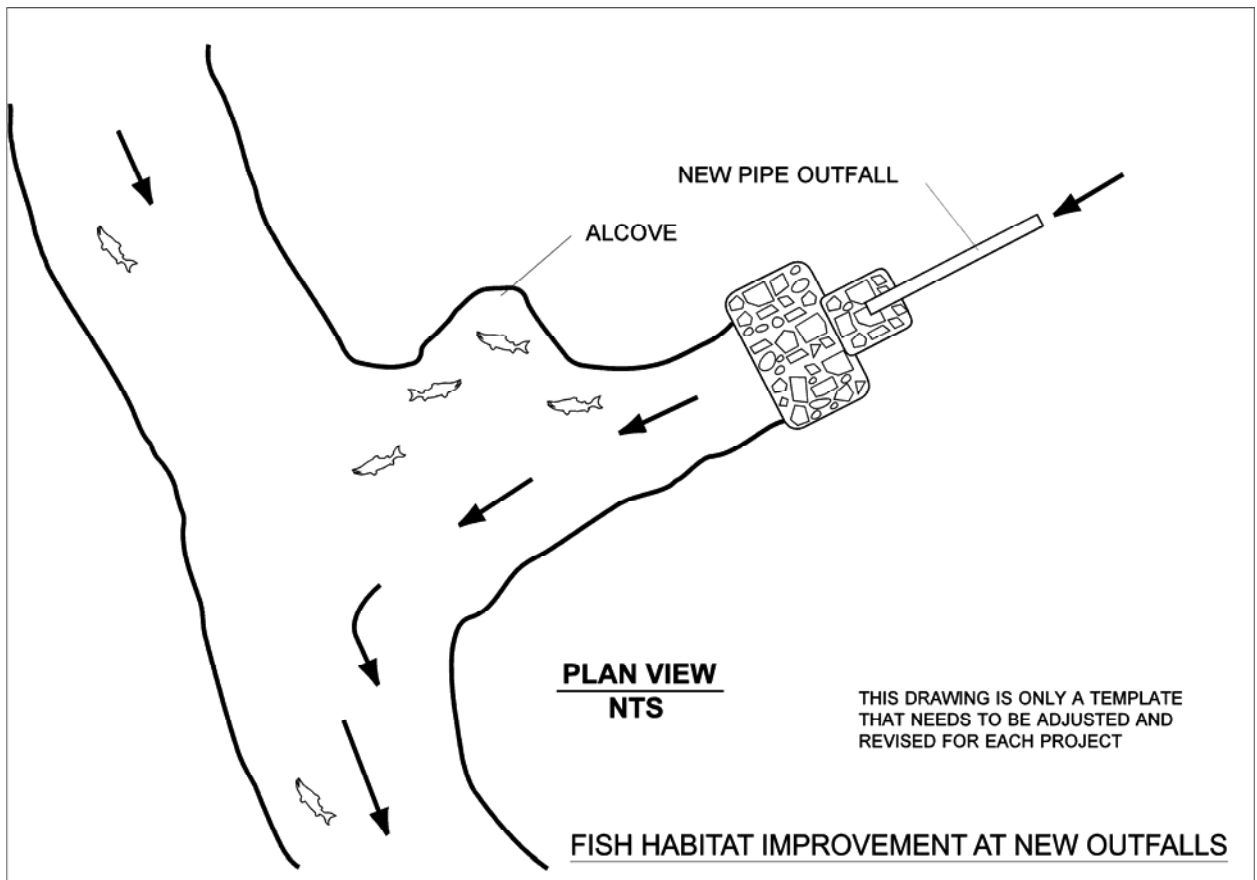

Figure 5.4.3.13. Fish habitat improvement at new outfalls.

Note: A Hydraulic Project Approval (RCW 77.55) may be required for any work within the ordinary high water level. Other provisions of this RCW or the Hydraulics Code (WAC 220-110) may also apply.

Outfall tight-lines may be installed in trenches with standard bedding on slopes up to 20%. To minimize disturbance to slopes greater than 20%, it is recommended that tight-lines be placed at grade with proper pipe anchorage and support.

Except as indicated above, tight-lines or conveyances that traverse the marine intertidal zone and connect to outfalls must be buried deep enough to avoid exposure of the line during storm events or future changes in beach elevation. If non-native material is used to bed the tight-line, such material must be covered with at least 3 feet of native bed material or equivalent.

High-density polyethylene (HDPE) pipe tight-lines must be designed to address the material limitations, particularly thermal expansion and contraction and pressure design, as specified by the manufacturer. The coefficient of thermal expansion and contraction for solid wall polyethylene (SWPE) pipe is on the order of 0.001-inch per foot per degree Fahrenheit. Sliding sleeve connections must be used to address this thermal expansion and contraction. These sleeve connections consist of a section of the appropriate length of the next larger size diameter of pipe into which the outfall pipe is fitted. The sleeve connections must be located as close to the discharge end of the outfall system as is practicable.

Due to the ability of HDPE pipe tight-lines to transmit flows of very high energy, special consideration for energy dissipation must be made. Details of a typical gabion mattress energy dissipater are included in Figure 5.4.3.11. Flows of very high energy require a specifically engineered energy dissipater structure.

5-5 Operation and Maintenance

Inadequate maintenance is a common cause of failure for stormwater control facilities. All stormwater facilities require routine inspection and maintenance and thus must be designed so that these functions can be easily conducted.

5-5.1 Typical BMP Maintenance Standards

The facility-specific maintenance standards contained in this section (see [Tables 5.5.1 through 5.5.13](#)) are intended to be used for determining when maintenance actions are required for conditions identified through inspection. They are not intended to be measures of a facility's required condition at all times between inspections. In other words, exceeding these conditions at any time between inspections or maintenance does not automatically constitute a need for immediate maintenance. Based upon inspection observations, however, the inspection and maintenance schedules must be adjusted to minimize the length of time that a facility is in a condition that requires a maintenance action.

5-5.2 Natural and Landscaped Areas Designated as Stormwater Management Facilities

Maintenance of natural and landscaped areas designated as stormwater management facilities requires special attention. Generally, maintenance in these areas should be performed with light equipment. Heavy machinery and vehicles with large treads or tires can compact the ground surface, decreasing the effectiveness of the BMPs.

Table 5.5.1. Maintenance standards for detention ponds.

Maintenance Component	Defect or Problem	Condition When Maintenance is Needed	Results Expected When Maintenance is Performed
General	Trash and debris	Accumulations exceed 5 cubic feet (about equal to the amount of trash needed to fill one standard-size garbage can) per 1,000 square feet. In general, there should be no visual evidence of dumping. If less than threshold, all trash and debris will be removed as part of the next scheduled maintenance.	Trash and debris are cleared from site.
	Poisonous vegetation and noxious weeds	Poisonous or nuisance vegetation may constitute a hazard to maintenance personnel or the public. Noxious weeds as defined by state or local regulations are evident. (Apply requirements of adopted integrated pest management [IPM] policies for the use of herbicides).	No danger is posed by poisonous vegetation where maintenance personnel or the public might normally be. (Coordinate with local health department.) Complete eradication of noxious weeds may not be possible. Compliance with state or local eradication policies is required.
	Contaminants and pollution	Oil, gasoline, contaminants, or other pollutants are evident. (Coordinate removal/cleanup with local water quality response agency.)	No contaminants or pollutants are present.
	Rodent holes	For facilities acting as a dam or berm: rodent holes are evident or there is evidence of water piping through dam or berm via rodent holes.	Rodents are destroyed and dam or berm repaired. (Coordinate with local health department; coordinate with Ecology Dam Safety Office if pond exceeds 10 acre-feet.)
	Beaver dams	Dam results in change or function of the facility.	Facility is returned to design function. (Coordinate trapping of beavers and removal of dams with appropriate permitting agencies.)
	Insects	Insects such as wasps and hornets interfere with maintenance activities.	Insects are destroyed or removed from site. Insecticides are applied in compliance with adopted IPM policies.
	Tree growth and hazard trees	Tree growth does not allow maintenance access or interferes with maintenance activity (slope mowing, silt removal, vactoring, or equipment movements). If trees are not interfering with access or maintenance, do not remove. Dead, diseased, or dying trees are observed. (Use a certified arborist to determine health of tree or removal requirements.)	Trees do not hinder maintenance activities. Harvested trees should be recycled into mulch or other beneficial uses (such as alders for firewood). Hazard trees are removed.
Side slopes of pond	Erosion	Eroded damage is over 2 inches deep and cause of damage is still present, or there is potential for continued erosion. Erosion is observed on a compacted berm embankment.	Slopes are stabilized using appropriate erosion control measures (such as rock reinforcement, planting of grass, and compaction). If erosion is occurring on compacted berms, a licensed civil engineer should be consulted to resolve source of erosion.

Maintenance Component	Defect or Problem	Condition When Maintenance is Needed	Results Expected When Maintenance is Performed
Storage area	Sediment	Accumulated sediment exceeds 10% of the designed pond depth, unless otherwise specified, or affects inletting or outletting condition of the facility.	Sediment is cleaned out to designed pond shape and depth. Pond is reseeded if necessary to control erosion.
	Liner (if applicable)	Liner is visible and has more than three ¼-inch holes in it.	Liner is repaired or replaced. Liner is fully covered.
Pond berms (dikes)	Settlements	Any part of berm has settled 4 inches lower than the design elevation. If settlement is apparent, measure berm to determine amount of settlement. Settling can be an indication of more severe problems with the berm or outlet works. A licensed civil engineer should be consulted to determine the source of the settlement.	Dike is built back to the design elevation.
	Piping	Water flow is discernible through pond berm. Ongoing erosion is observed, with potential for erosion to continue. (Recommend a geotechnical engineer be called in to inspect and evaluate condition and recommend repair of condition.)	Piping is eliminated. Erosion potential is resolved.
Emergency overflow/spillway and berms over 4 feet high	Tree growth	Tree growth on emergency spillways reduces spillway conveyance capacity and may cause erosion elsewhere on the pond perimeter due to uncontrolled overtopping. Tree growth on berms over 4 feet high may lead to piping through the berm, which could lead to failure of the berm and related erosion or flood damage.	Trees should be removed. If root system is small (base less than 4 inches), the root system may be left in place; otherwise, the roots should be removed and the berm restored. A licensed civil engineer should be consulted for proper berm/spillway restoration.
	Piping	Water flow is discernible through pond berm. Ongoing erosion is observed, with potential for erosion to continue. (Recommend a geotechnical engineer be called in to inspect and evaluate condition and recommend repair of condition.)	Piping is eliminated. Erosion potential is resolved.
Emergency overflow/spillway	Spillway lining insufficient	Only one layer of rock exists above native soil in area 5 square feet or larger, or native soil is exposed at the top of outflow path of spillway. (Riprap on inside slopes need not be replaced.)	Rocks and pad depth are restored to design standards.

Table 5.5.2. Maintenance standards for bioinfiltration ponds/infiltration trenches/basins.

Maintenance Component	Defect or Problem	Condition When Maintenance is Needed	Results Expected When Maintenance is Performed
General	Trash and debris	See Table 5.5.13 (wet ponds).	See Table 5.5.13 (wet ponds).
	Poisonous/noxious vegetation	See Table 5.5.13 (wet ponds).	See Table 5.5.13 (wet ponds).
	Contaminants and pollution	See Table 5.5.13 (wet ponds).	See Table 5.5.13 (wet ponds).
	Rodent holes	See Table 5.5.13 (wet ponds).	See Table 5.5.13 (wet ponds).
Storage area	Sediment	Water ponds in infiltration pond after rainfall ceases and appropriate time has been allowed for infiltration. (A percolation test pit or test of facility indicates facility is working at only 90% of its designed capabilities. If 2 inches or more of sediment present, remove sediment).	Sediment is removed or facility is cleaned so that infiltration system works according to design.
Rock filters	Sediment and debris	By visual inspection, little or no water flows through filter during heavy rainstorms.	Gravel in rock filter is replaced.
Side slopes of pond	Erosion	See Table 5.5.13 (wet ponds).	See Table 5.5.13 (wet ponds).
Emergency overflow/spillway and berms over 4 feet high	Tree growth	See Table 5.5.13 (wet ponds).	See Table 5.5.13 (wet ponds).
	Piping	See Table 5.5.13 (wet ponds).	See Table 5.5.13 (wet ponds).
Emergency overflow/spillway	Rock missing	See Table 5.5.13 (wet ponds).	See Table 5.5.13 (wet ponds).
	Erosion	See Table 5.5.13 (wet ponds).	See Table 5.5.13 (wet ponds).
Presettling ponds and vaults	Facility or sump filled with sediment or debris	Sediment/debris exceeds 6 inches or designed sediment trap depth.	Sediment is removed.

Table 5.5.3. Maintenance standards for closed treatment systems (tanks/vaults).

Maintenance Component	Defect or Problem	Condition When Maintenance is Needed	Results Expected When Maintenance is Performed
Storage area	Plugged air vents	One-half of the cross section of a vent is blocked at any point or the vent is damaged.	Vents are open and functioning.
	Debris and sediment	Accumulated sediment depth exceeds 10% of the diameter of the storage area for ½ length of storage vault or any point depth exceeds 15% of diameter. (Example: 72-inch storage tank requires cleaning when sediment reaches depth of 7 inches for more than ½ the length of the tank.)	All sediment and debris are removed from storage area.
	Joints between tank/pipe section	Openings or voids allow material to be transported into facility. (Will require engineering analysis to determine structural stability.)	All joints between tank/pipe sections are sealed.
	Tank/pipe bent out of shape	Any part of tank/pipe is bent out of shape for more than 10% of its design shape. (Review required by engineer to determine structural stability.)	Tank/pipe is repaired or replaced to design specifications.
	Vault structure: includes cracks in walls or bottom, damage to frame or top slab	Cracks are wider than ½ inch and there is evidence of soil particles entering the structure through the cracks, or maintenance/inspection personnel determine that the vault is not structurally sound.	Vault is replaced or repaired to design specifications and is structurally sound.
		Cracks are wider than ½ inch at the joint of any inlet/outlet pipe, or there is evidence of soil particles entering the vault through the walls.	No cracks are more than ¼-inch wide at the joint of the inlet/outlet pipe.
Manhole	Cover not in place	Cover is missing or only partially in place. Any open manhole requires maintenance.	Manhole is closed.
	Locking mechanism not working	Mechanism cannot be opened by one maintenance person with proper tools. Bolts into frame have less than ½ inch of thread (may not apply to self-locking lids).	Mechanism opens with proper tools.
	Cover difficult to remove	One maintenance person cannot remove lid after applying normal lifting pressure. <i>Intent: To prevent cover from sealing off access to maintenance.</i>	Cover can be removed and reinstalled by one maintenance person.
	Ladder unsafe	Ladder is unsafe due to missing rungs, misalignment, insecure attachment to structure wall, rust, or cracks.	Ladder meets design standards. Allows maintenance person safe access.
Catch basins	See Table 5.5.5 (catch basins).	See Table 5.5.5 (catch basins).	See Table 5.5.5 (catch basins).

Table 5.5.4. Maintenance standards for control structure/flow restrictor.

Maintenance Component	Defect or Problem	Condition When Maintenance is Needed	Results Expected When Maintenance is Performed
General	Trash and debris (includes sediment)	Accumulation exceeds 25% of sump depth or is within 1 foot below orifice plate.	Control structure orifice is not blocked. All trash and debris are removed.
	Structural damage	Structure is not securely attached to manhole wall.	Structure is securely attached to wall and outlet pipe.
		Structure is not in upright position; allow up to 10% from plumb.	Structure is in correct position.
		Connections to outlet pipe are not watertight and show signs of rust.	Connections to outlet pipe are watertight; structure is repaired or replaced and works as designed.
		Holes other than designed holes are observed in the structure.	Structure has no holes other than designed holes.
Cleanout gate	Damaged or missing	Cleanout gate is not watertight or is missing.	Gate is watertight and works as designed.
		Gate cannot be moved up and down by one maintenance person.	Gate moves up and down easily and is watertight.
		Chain/rod leading to gate is missing or damaged.	Chain is in place and works as designed.
		Gate is rusted over 50% of its surface area.	Gate is repaired or replaced to meet design standards.
Orifice plate	Damaged or missing	Control device is not working properly due to missing, out-of-place, or bent orifice plate.	Plate is in place and works as designed.
	Obstructions	Trash, debris, sediment, or vegetation blocks the plate.	Plate is free of all obstructions and works as designed.
Overflow pipe	Obstructions	Trash or debris blocks (or has the potential to block) the overflow pipe.	Pipe is free of all obstructions and works as designed.
Manhole	See Table 5.5.3 (closed treatment systems).	See Table 5.5.3 (closed treatment systems).	See Table 5.5.3 (closed treatment systems).
Catch basin	See Table 5.5.5 (catch basins).	See Table 5.5.5 (catch basins).	See Table 5.5.5 (catch basins).

Table 5.5.5. Maintenance standards for catch basins.

Maintenance Component	Defect or Problem	Condition When Maintenance is Needed	Results Expected When Maintenance is Performed
General	Trash and debris	Trash or debris is immediately in front of the catch basin opening or is blocking inletting capacity of the basin by more than 10%.	No trash or debris is immediately in front of catch basin or on grate opening.
		Trash or debris (in the basin) exceeds 60% of the sump depth as measured from the bottom of basin to invert of the lowest pipe into or out of the basin, but in no case is clearance less than 6 inches from the debris surface to the invert of the lowest pipe.	No trash or debris is in the catch basin.
		Trash or debris in any inlet or outlet pipe blocks more than $\frac{1}{3}$ of its height.	Inlet and outlet pipes are free of trash or debris.
		Dead animals or vegetation could generate odors that might cause complaints or dangerous gases (such as methane).	No vegetation or dead animals are present within the catch basin.
	Sediment	Sediment (in the basin) exceeds 60% of the sump depth as measured from the bottom of the basin to invert of the lowest pipe into or out of the basin, but in no case is clearance less than 6 inches from the sediment surface to the invert of the lowest pipe.	No sediment is in the catch basin.
		Structure damage to frame and/or top slab	Top slab has holes larger than 2 square inches or cracks wider than $\frac{1}{4}$ inch. <i>Intent: To make sure no material is running into basin.</i>
	Frame is not sitting flush on top slab (separation of more than $\frac{3}{4}$ inch of the frame from the top slab). Frame is not securely attached.		Frame is sitting flush on the riser rings or top slab and is firmly attached.
	Fractures or cracks in basin walls/bottom	Maintenance person judges that structure is unsound.	Basin is replaced or repaired to design standards.
		Grout fillet has separated or cracked wider than $\frac{1}{2}$ inch and longer than 1 foot at the joint of any inlet/outlet pipe, or there is evidence that soil particles have entered catch basin through cracks.	Pipe is regouted and secure at the basin wall.
	Settlement/misalignment	Failure of basin has created a safety, function, or design problem.	Basin is replaced or repaired to design standards.
	Vegetation	Vegetation is growing across and blocking more than 10% of the basin opening.	No vegetation blocks the opening to the basin.
		Vegetation growing in inlet/outlet pipe joints is more than 6 inches tall and less than 6 inches apart.	No vegetation or root growth is present.
	Contamination and pollution	Oil, gasoline, contaminants, or other pollutants are evident. (Coordinate removal/cleanup with local water quality response agency.)	No pollution is present.
Catch basin cover	Cover not in place	Cover is missing or only partially in place. Any open catch basin requires maintenance.	Catch basin cover is closed.
	Locking mechanism not working	Mechanism cannot be opened by one maintenance person with proper tools. Bolts into frame have less than $\frac{1}{2}$ inch of thread.	Mechanism opens with proper tools.

Maintenance Component	Defect or Problem	Condition When Maintenance is Needed	Results Expected When Maintenance is Performed
Catch basin cover (continued)	Cover difficult to remove	One maintenance person cannot remove lid after applying normal lifting pressure. <i>Intent: To prevent cover from sealing off access to maintenance.</i>	Cover can be removed by one maintenance person.
Ladder	Ladder unsafe	Ladder is unsafe due to missing rungs, insecure attachment to basin wall, misalignment, rust, cracks, or sharp edges.	Ladder meets design standards and allows maintenance staff safe access.
Metal grates (if applicable)	Grate opening unsafe	Grate opening is wider than 7/8 inch.	Grate opening meets design standards.
	Trash and debris	Trash and debris block more than 20% of grate surface inletting capacity.	Grate is free of trash and debris.
	Damaged or missing	Grate is missing or components of the grate are broken.	Grate is in place and meets design standards.

Table 5.5.6. Maintenance standards for debris barriers (such as trash racks).

Maintenance Components	Defect or Problem	Condition When Maintenance is Needed	Results Expected When Maintenance is Performed
General	Trash and debris	Trash or debris plugs more than 20% of the openings in the barrier.	Barrier is cleared to design flow capacity.
Metal	Damaged/missing bars	Bars are bent out of shape more than 3 inches.	Bars are in place with no bends more than 3/4 inch.
		Bars are missing or entire barrier is missing.	Bars are in place according to design.
		Bars are loose and rust is causing 50% deterioration to any part of barrier.	Barrier is replaced or repaired to design standards.
	Inlet/outlet pipe	Debris barrier is missing or not attached to pipe.	Barrier is firmly attached to pipe.

Table 5.5.7. Maintenance standards for energy dissipaters.

Maintenance Components	Defect or Problem	Condition When Maintenance is Needed	Results Expected When Maintenance is Performed
External:			
Rock pad	Missing or moved rock	Only one layer of rock exists above native soil in area 5 square feet or larger, or native soil is exposed.	Rock pad is replaced to design standards.
	Erosion	Soil erosion is evident in or adjacent to rock pad.	Rock pad is replaced to design standards.
Dispersion trench	Pipe plugged with sediment	Accumulated sediment exceeds 20% of the design depth.	Pipe is cleaned/flushed so that it matches design.
	Not discharging water properly	There is visual evidence of water discharging at concentrated points along trench—normal condition is a “sheet flow” of water along trench. <i>Intent: To prevent erosion damage.</i>	Trench is redesigned or rebuilt to standards.
	Perforations plugged	Over ½ of perforations in pipe are plugged with debris and sediment.	Perforated pipe is cleaned or replaced.
	Water flows out top of “distributor” catch basin	Maintenance person observes or receives credible report of water flowing out during any storm less than the design storm, or water is causing (or appears likely to cause) damage.	Facility is rebuilt or redesigned to standards.
	Receiving area over-saturated	Water in receiving area is causing (or has potential of causing) landslide problems.	There is no danger of landslides.
Internal:			
Manhole/chamber	Worn or damaged post, baffles, side of chamber	Structure dissipating flow deteriorates to ½ of original size or any concentrated worn spot exceeds 1 square foot, which would make structure unsound.	Structure is replaced to design standards.
	Other defects	See entire contents of Table 5.5.5 (catch basins).	See entire contents of Table 5.5.5 (catch basins).

Table 5.5.8. Maintenance standards for biofiltration swale.

Maintenance Component	Defect or Problem	Condition When Maintenance is Needed	Recommended Maintenance to Correct Problem
General	Sediment accumulation on grass	Sediment depth exceeds 2 inches.	Remove sediment deposits on grass treatment area of the swale. When finished, swale should be level from side to side and drain freely toward outlet. There should be no areas of standing water once inflow has ceased.
	Standing water	Water stands in the swale between storms and does not drain freely.	Any of the following may apply: remove sediment or trash blockages; improve grade from head to foot of swale; remove clogged check dams; add underdrains; or convert to a wet biofiltration swale.
	Flow spreader	Flow spreader is uneven or clogged so that flows are not uniformly distributed through entire swale width.	Level the spreader and clean so that flows are spread evenly over entire swale width.
	Constant baseflow	Small quantities of water continually flow through the swale, even when it has been dry for weeks, and an eroded, muddy channel has formed in the swale bottom.	Add a low-flow pea gravel drain the length of the swale, or bypass the baseflow around the swale.
	Poor vegetation coverage	Grass is sparse or bare, or eroded patches occur in more than 10% of the swale bottom.	Determine why grass growth is poor and correct that condition. Replant with plugs of grass from the upper slope; plant in the swale bottom at 8-inch intervals; or reseed into loosened, fertile soil.
	Vegetation	Grass becomes excessively tall (greater than 10 inches); nuisance weeds and other vegetation start to take over.	Mow vegetation or remove nuisance vegetation so that flow is not impeded. Grass should be mowed to a height of 6 inches. Mowing is not required for wet biofiltration swales. However, fall harvesting of very dense vegetation after plant die-back is recommended.
	Excessive shading	Grass growth is poor because sunlight does not reach swale.	If possible, trim back overhanging limbs and remove brushy vegetation on adjacent slopes.
	Inlet/outlet	Inlet/outlet areas are clogged with sediment/debris.	Remove material so there is no clogging or blockage in the inlet and outlet area.
	Trash and debris	Trash and debris have accumulated in the swale.	Remove trash and debris from bioswale.
Erosion/scouring	Swale bottom has eroded or scoured due to flow channelization or high flows.	For ruts or bare areas less than 12 inches wide, repair the damaged area by filling with crushed gravel. If bare areas are large (generally greater than 12 inches wide), the swale should be regraded and reseeded. For smaller bare areas, overseed when bare spots are evident, or take plugs of grass from the upper slope and plant in the swale bottom at 8-inch intervals.	

Table 5.5.9. Maintenance standards for vegetated filter strip.

Maintenance Component	Defect or Problem	Condition When Maintenance is Needed	Recommended Maintenance to Correct Problem
General	Sediment accumulation on grass	Sediment depth exceeds 2 inches.	Remove sediment deposits. Relevel so slope is even and flows pass evenly through strip.
	Vegetation	Grass becomes excessively tall (greater than 10 inches); nuisance weeds and other vegetation start to take over.	Mow grass and control nuisance vegetation so that flow is not impeded. Grass should be mowed to a height between 3 and 4 inches.
	Trash and debris	Trash and debris have accumulated on the vegetated filter strip.	Remove trash and debris from filter.
	Erosion/scouring	Areas have eroded or scoured due to flow channelization or high flows.	For ruts or bare areas less than 12 inches wide, repair the damaged area by filling with crushed gravel. The grass will creep in over the rock in time. If bare areas are large, generally greater than 12 inches wide, the vegetated filter strip should be regraded and reseeded. For smaller bare areas, overseed when bare spots are evident.
	Flow spreader	Flow spreader is uneven or clogged so that flows are not uniformly distributed over entire filter width.	Level the spreader and clean so that flows are spread evenly over entire filter width.

Table 5.5.10. Maintenance standards for media filter drain.

Maintenance Component	Defect or Problem	Condition When Maintenance is Needed	Recommended Maintenance to Correct Problem
General	Sediment accumulation on grass filter strip	Sediment depth exceeds 2 inches or creates uneven grading that interferes with sheet flow.	Remove sediment deposits on grass treatment area of the embankment. When finished, embankment should be level from side to side and drain freely toward the toe of the embankment slope. There should be no areas of standing water once inflow has ceased.
	No-vegetation zone/flow spreader	Flow spreader is uneven or clogged so that flows are not uniformly distributed over entire embankment width.	Level the spreader and clean so that flows are spread evenly over entire embankment width.
	Poor vegetation coverage	Grass is sparse or bare, or eroded patches are observed in more than 10% of the <u>grass strip</u> surface area.	Consult with roadside vegetation specialists to determine why grass growth is poor and correct the offending condition. Replant with plugs of grass from the upper slope or reseed into loosened, fertile soil or compost.
	Vegetation	Grass becomes excessively tall (greater than 10 inches); nuisance weeds and other vegetation start to take over.	Mow vegetation or remove nuisance vegetation so that flow is not impeded. Grass should be mowed to a height of <u>6</u> inches.
	<u>Media filter drain mix</u> replacement	Water is seen on the surface of the <u>media filter drain mix</u> from storms that are less than a 6-month, 24-hour precipitation event. Maintenance also needed on a 10-year cycle and during a preservation project.	Excavate and replace all of the <u>media filter drain mix</u> contained within the <u>media filter drain</u> .
	Excessive shading	Grass growth is poor because sunlight does not reach embankment.	If possible, trim back overhanging limbs and remove brushy vegetation on adjacent slopes.
	Trash and debris	Trash and debris have accumulated on embankment.	Remove trash and debris from embankment.

Table 5.5.11. Maintenance standards for permeable pavement.

Maintenance Component	Defect or Problem	Condition When Maintenance is Needed	Recommended Maintenance to Correct Problem
General	Sediment accumulation	Collection of sediment is too coarse to pass through pavement.	Remove sediment deposits with high-pressure vacuum sweeper.
	Accumulation of leaves, needles, and other foliage	Accumulation on top of pavement is observed.	Remove with a leaf blower or high-pressure vacuum sweeper.
	Trash and debris	Trash and debris have accumulated on the pavement.	Remove by hand or with a high-pressure vacuum sweeper.
	Oil accumulation	Oil collection is observed on top of pavement.	Immediately remove with a vacuum and follow up by a pressure wash or other appropriate rinse procedure.
Visual facility identification	Not aware of permeable pavement location	Facility markers are missing or not readable.	Replace facility identification where needed.
Annual minimum maintenance			Remove potential void-clogging debris with a biannual or annual high-pressure vacuum sweeping.

Table 5.5.12. Maintenance standards for dispersion areas (natural and engineered).

Maintenance Component	Defect or Problem	Condition When Maintenance is Needed	Recommended Maintenance to Correct Problem
General	Sediment accumulation on dispersion area	Sediment depth exceeds 2 inches.	Remove sediment deposits while minimizing compaction of soils in dispersion area. Relevel so slope is even and flows pass evenly over/through dispersion area. Handwork is recommended rather than use of heavy machinery.
	Vegetation	Vegetation is sparse or dying; significant areas are without ground cover.	Control nuisance vegetation. Add vegetation, preferably native ground cover, bushes, and trees (where consistent with safety standards) to bare areas or areas where the initial plantings have died.
	Trash and debris	Trash and debris have accumulated on the dispersion area.	Remove trash and debris from filter. Handwork is recommended rather than use of heavy machinery.
	Erosion/scouring	Eroded or scoured areas due to flow channelization, or high flows are observed.	For ruts or bare areas less than 12 inches wide, repair the damaged area by filling with crushed gravel/compost mix (see Section 5-4.3.2 for the compost specifications). The grass will creep in over the rock mix in time. If bare areas are large (generally greater than 12 inches wide), the dispersion area should be reseeded. For smaller bare areas, overseed when bare spots are evident. Look for opportunities to locate flow spreaders, such as dispersion trenches and rock pads.
	Flow spreader	Flow spreader is uneven or clogged so that flows are not uniformly distributed over entire filter width.	Level the spreader and clean so that flows are spread evenly over entire filter width.

Table 5.5.13. Maintenance standards for wet ponds.

Maintenance Component	Defect or Problem	Condition When Maintenance is Needed	Recommended Maintenance to Correct Problem
General	Water level	First cell is empty, doesn't hold water	Line the first cell to maintain at least 4 feet of water. Although the second cell may drain, the first cell must remain full to control turbulence of the incoming flow and reduce sediment resuspension.
	Trash and debris	Accumulations exceed 1 cubic foot per 1000 square feet of pond area.	Remove trash and debris from pond.
	Inlet/outlet pipe	Inlet/outlet pipe is clogged with sediment or debris material.	Unclog and unblock inlet and outlet piping.
	Sediment accumulation in pond bottom	Sediment accumulations in pond bottom exceed the depth of sediment zone plus 6 inches, usually in the first cell.	Remove sediment from pond bottom.
	Oil sheen on water	Oil sheen is prevalent and visible.	Remove oil from water using oil-absorbent pads or Vactor truck. Locate and correct source of oil. If chronic low levels of oil persist, plant wetland species such as <i>Juncus effusus</i> (soft rush), which can uptake small concentrations of oil.
	Erosion	Pond side slopes or bottom show evidence of erosion or scouring in excess of 6 inches and the potential for continued erosion is evident.	Stabilize slopes using proper erosion control measures and repair methods.
	Settlement of pond dike/berm	Any part of the pond dike/berm has settled 4 inches or lower than the design elevation, or the inspector determines dike/berm is unsound.	Repair dike/berm to specifications.
	Internal berm	Berm dividing cells are not level.	Level berm surface so that water flows evenly over entire length of berm.
	Overflow/spillway	Rock is missing and soil exposed at top of spillway or outside slope.	Replace rocks to specifications.

5-5.2.1 Documenting and Preserving Intended Functions

Natural and landscaped areas designated as stormwater management facilities must be identified in the field and documented for future reference. The locations of these areas are documented in the WSDOT GIS Workbench, right of way plans, and as-built plans. During the post-construction meeting, these treatment facilities are identified to maintenance personnel. Note: Specially marked delineators are placed to notify maintenance personnel that a sensitive feature is in the area. The type and placement of this marker must be worked out between the maintenance and design offices.

5-5.2.2 Sensitive Area Mapping

State roadways have been surveyed to provide information to WSDOT maintenance crews so that BMPs may be employed to eliminate or reduce the impacts of maintenance activities on streams, wetlands, and water bodies. The primary objective of the survey was to identify all locations where these sensitive areas are within 300 feet of a roadway. A secondary objective was to note those areas that are particularly sensitive or insensitive in order to support appropriate maintenance actions and application of BMPs. This effort does not eliminate the need for detailed biological evaluation of resources during highway project planning. This survey information is located on the GIS Workbench. When wetlands on WSDOT-owned right of way are delineated and new wetlands created, this information must be documented in the GIS Workbench. The GIS Workbench is used to update the Maintenance Roadside Sensitive Area Atlases.

5-5.2.3 Stormwater Inventory

The stormwater database can be a valuable tool for design engineers. The stormwater database contains all of the data used to prioritize stand-alone stormwater retrofit projects. In addition to the data used to derive retrofit priorities for each outfall, several hundred complete records contain BMP retrofit recommendations, conceptual design information, BMP cost estimates, drainage basin characteristics, conveyance system information, photographs, field sketches, and preliminary facility sizing calculations. To obtain stormwater database information about specific outfalls, contact the Region Hydraulics and Water Quality offices or the HQ ESO Stormwater & Watersheds Program. Further information is available in Section 3-3.7.

5-6 References

- API. 1990. Design and operation of oil-water separators. American Petroleum Institute Publication 421, February 1990.
- Bureau of Reclamation. 1978. Hydraulic design of stilling basins and energy dissipaters, Publication EM 25. U.S. Bureau of Reclamation.
- Cahill, T.H., Adams, M., & Marm, C. (2003, September/October). Porous asphalt: The right choice for porous pavements. *Hot Mix Asphalt Technology*, 26-40.
- Cahill Associates. Section 02725 – General porous paving and groundwater infiltration beds. In *General Specifications only: Porous Paving 02725-1*
- Chang, G.C. 2000. Review of stormwater manual, sand filtration basins for Department of Ecology, State of Washington. November 5, 2000.
- Chollack, Tracy, et al., 2001. Porous Pavement Phase 1 Evaluation Report. Seattle Public Utilities, Report, Seattle, Washington. February 7, 2001.
- Chow, V.T. 1959. Open-channel flow. McGraw-Hill, Boston, MA.
- City of Austin. 1988. Design guidelines for water quality control basins, environmental criteria manual. June 1988. Austin, Texas.
- Claytor and Schueler. 1996. “Design of Stormwater Filtering Systems. Center for Watershed Protection. Chesapeake Research Consortium. Silver Spring, MD.
- Daugherty, R.L. and J.B. Franzini. 1977. “Fluid Mechanics with Engineering Applications,” McGraw-Hill, New York.
- Ecology. 2004. *Stormwater Management Manual for Eastern Washington*. Washington State Department of Ecology.
- Ecology. 2004. “Washington State Wetland Rating System for Eastern Washington.” Revised Ecology Publication # 04-06-15. Washington State Department of Ecology Publication.
☞ www.ecy.wa.gov/programs/sea/wetlandratings/pdf/0406015-part1.pdf
- Ecology. 2005. *Stormwater Management Manual for Western Washington*. Washington State Department of Ecology.
- Ecology. 2005. Washington State Wetland Rating System for Western Washington. Washington State Department of Ecology Publication.
☞ www.ecy.wa.gov/biblio/0406025.html

Federal Highway Administration. 2002. Construction of Pavement Subsurface Drainage Systems. Publication FHWA IF-01-014. Washington, D.C.

FHWA. 1983. Hydraulic design of energy dissipaters for culverts and channels. Hydraulic Engineering Circular No. 14 (HEC-14), FHWA-EPD-86-110. U.S. Department of Transportation, Federal Highway Administration.

FHWA. 1995. Geosynthetic design and construction guidelines. Publication No. FHWA HI-95-038. Federal Highway Administration. May 1995.

FHWA. 2002. Construction of pavement subsurface drainage systems. Publication No. FHWA-IF-01-014, HIPA-20/1-02(500). January 3, 2002. U.S. Department of Transportation, Federal Highway Administration.

Georgia Stormwater Management Manual, Section 3.3.5.

Harrison, R.B., M.A. Grey, C.L. Henry and D. Xue. 1997. Field test of compost amendment to reduce nutrient runoff, final report.

Hitchcock, G.L and A. Cronquist. 1973. Flora of the Pacific Northwest. University of Washington Press, Seattle.

Hortus Northwest. 1991. Wetland plants for western Oregon.

Jaisinghani, R.A., et al., 1979. A study of oil/water separation in corrugated plate separators. Journal of Engineering for Industry, November, 1979.

Kadlec, R.H. and R.L. Knight. 1996. Treatment Wetlands. Lewis Publishers, Boca Raton, FL. 893p.

King County. 1998. King County, *Washington Surface Water Design Manual*. King County Department of Natural Resources, Seattle, WA.

Lau, Marsalek, and Rochfort. 2000. Use of a biofilter for treatment of heavy metals in highway runoff. Water Quality Research Journal of Canada 35(3):563–580.

Mollick, R.B. et al., 2000. Design, Construction and Performance of New-Generation Open-Graded Friction Courses. National Center for Asphalt Technology. Auburn University, Alabama.

Metro. 1990. Water pollution control aspects of aquatic plants. Municipality of Metropolitan Seattle.

Miller, S. 2000. Criteria for assessing the trace element removal capacity of bio-filtration systems. Spokane County.

NCHRP. 1994. Long-term performance of geosynthetics in drainage applications. NCHRP Report 367.

Puget Sound Action Team. 2005. *Low Impact Development Technical Guidance Manual for Puget Sound*.

Prince George's County. 2001. *The Bioretention Manual*. Prince George's County Programs and Planning Division.

Schueler, Thomas, Peter Kumble, and Heraty, Anacostia Restoration Team, Metropolitan Washington Council of Governments. 1992. "A Current Assessment of Urban Best Management Practices: Techniques for Reducing Non-Point Source Pollution in the Coastal Zone." Prepared for U.S. Environmental Protection Agency.

Thullen, J.S., J.J. Sartoris, and W.E. Walton. 2002. "Effects of Vegetation Management in Constructed Wetlands Treatment Cells on Water Quality and Mosquito Production." *Ecological Engineering* 18 (2002) 441-457.

U.S. EPA. 1993. "Guidance Specifying Management Measures For Sources of Nonpoint Pollution In Coastal Waters." EPA-840-B-92-002. U.S. Environmental Protection Agency (USEPA), Office of Water, Washington, D.C.

U.S.A.F. Circa 1991. Gravity oil and water separator design criteria. U.S. Air Force.

U.S. COE. 1994. Selection and design of oil and water separators. U.S. Army Corps. of Engineers. August 26, 1994.

U.S. EPA Technology Fact Sheets. www.epa.gov/owm/mtb/mtbfact.htm

UW. 1994. Field test of compost amendment to reduce nutrient runoff. University of Washington, College of Forest Resources, Seattle, WA.

WEF and ASCE. 1998. Urban runoff quality management. Water Environment Federation and American Society of Civil Engineers.

WPCF. 1985. Clarifier Design. Water Pollution Control Federation: Manual of Practice. No. FD-8.

Young, G.K., S. Stein, P. Cole, T. Kammer, F. Graziano, and F. Bank. 1996. "Evaluation and Management of Highway Runoff Water Quality." FHWA-PD-96-032, Federal Highway Administration.

**Temporary Erosion and Sediment
Control Design Guidelines and Process**

Chapter 6. Table of Contents

Chapter 6. Temporary Erosion and Sediment Control Design Guidelines and Process	6-1
6-1 Introduction	6-1
6-2 Temporary Erosion and Sediment Control (TESC) Plan	6-2
6-2.1 Step-by-Step Procedure for Preparing TESC Plans	6-3
6-2.1.1 Data Collection and Risk Analysis	6-3
6-2.1.2 BMP Selection/TESC Elements	6-6
6-2.1.3 Schedule	6-15
6-2.1.4 Narrative and Plan Sheets	6-17
6-2.2 Contracting	6-18
6-3 Spill Prevention Control and Countermeasures Plan	6-19
6-4 Water Quality Sampling and Reporting Procedures	6-20
6-5 Standard Sampling Procedures	6-20
6-6 Office Data Recording and Analysis	6-23
6-7 Reporting Sampling Results and Compliance Issues	6-23
6-8 NPDES General Construction Permit Sampling Procedures	6-24
6-9 In-Water Work Monitoring	6-30
Appendix 6A. Best Management Practices	

List of Figures

Figure 6-5.1. General layout of NPDES General Construction Permit water quality sampling location	6-24
Figure 6-5.2. General layout of typical in-water work sampling locations	6-28

Chapter 6. Temporary Erosion and Sediment Control Design Guidelines and Process

6-1 Introduction

The primary focus of construction stormwater planning is to prevent sediment and other pollutants associated with construction activity from impacting soil, air, and water quality. Such impacts can increase project costs through regulatory and legal fines and through repair of site damage that causes delays to project delivery.

Temporary erosion and sediment control (TESC) plans and spill prevention control and countermeasures (SPCC) plans are required to adequately and systematically identify and minimize project risk. Together, the TESC and SPCC plans satisfy the construction Stormwater Pollution Prevention Plan (SWPPP) requirements.

All projects that disturb soil must comply with the 12 TESC elements (see Section 6-2.1.2) and must apply the appropriate best management practices (BMPs) presented in this chapter. A TESC plan must be prepared if a construction project adds or replaces—removes existing road surface down to base course—more than 2,000 square feet of impervious surface or disturbs more than 7,000 square feet of soil. Projects that do not meet these thresholds must address erosion control and the 12 TESC elements; however, a stand-alone TESC plan is optional and plan sheets are not required.

All Washington State Department of Transportation (WSDOT) staff designing or implementing TESC plans must attend the Construction Site Erosion and Sediment Control Course (course code BPW). WSDOT TESC plan designers should also attend the TESC Planning Tool training (course code CAY). Consultants who will be creating TESC plans for WSDOT projects should attend WSDOT's Construction Site Erosion and Sediment Control Course. Contact the Statewide Erosion Control Coordinator (360-570-6649) for class dates, locations, availability, and training registration.

SPCC plans are prepared by the contractor as required in the *Standard Specifications for Road, Bridge, and Municipal Construction (Standard Specifications)*, Section 1-07.15(1). Instructions for plan preparation are available to contractors at the Headquarters (HQ) Hazardous Materials Program website:

☞ www.wsdot.wa.gov/Environment/HazMat/SpillPrevention.htm

6-2 Temporary Erosion and Sediment Control (TESC) Plan

The purpose of a TESC plan is to clearly establish when and where specific BMPs will be implemented to prevent erosion and the transport of sediment from a site during construction. A TESC plan must address the 12 TESC elements, which are described later in this chapter.

A TESC plan consists of a narrative section and plan sheets. The narrative section includes an analysis of pollution risk for each TESC element as well as documentation to explain and justify the pollution prevention decisions made for the project. The TESC plan sheets show the BMP locations and other features such as topography and sensitive area locations for multiple project stages. It is recommended that large projects that will be under construction for multiple seasons create phased TESC plans, with one year of construction focusing on the wet seasons.

The following information must be included in the narrative: existing site conditions (such as topography, drainage, soils, and vegetation); potential erosion problem areas; BMPs chosen to address risks as well as a list of applicable *Standard Specifications*, General Special Provisions (GSPs), and Special Provisions; construction phasing/sequence and general BMP implementation schedule (to be confirmed at preconstruction meeting with contractor); and the actions to be taken if BMP performance goals are not achieved.

The contract plan sheets must include: the direction of north, property lines, and existing structures and roads; cut and fill slopes indicating the top and bottom of slope catch lines; approximate slopes, contours, and direction of stormwater flow before and after major grading activities; areas of soil disturbance and areas that will not be disturbed; locations of structural and nonstructural controls (BMPs); locations of off-site material, stockpiles, waste storage, borrow areas, and vehicle/equipment storage areas that are covered under WSDOT permits; locations of all surface water bodies, including wetlands; locations where stormwater or nonstormwater discharges off-site or to a surface water body, including wetlands; location of water quality sampling stations; and areas where final stabilization has been accomplished and no further construction-phase permit requirements apply.

The HQ Erosion Control Program offers an 8-hour Construction Site Erosion and Sediment Control Course, which covers water quality monitoring, TESC planning, and basic principles of erosion and provides in-depth analysis of BMPs. WSDOT staff who have previously taken this 8-hour course will be required to attend the Environmental Refresher Course (course code C41 in ATMS) every two years.

WSDOT has a web-based planning tool that helps designers create thorough and contractually enforceable TESC plans. The designer reviews requirements, selects BMPs, and identifies contractual tools to ensure enforcement of TESC plans. The planning tool helps ensure consistency in plan format as it automatically organizes and writes the TESC plan narrative. It also greatly accelerates the process for TESC plan review. Training is

available in ATMS (course code CAY). For further information, contact the Erosion Control Coordinator at the HQ Environmental Services Office (ESO).

A TESC plan template, which provides information on how to create an effective TESC plan, is available online for non-WSDOT TESC plan designers at the HQ Erosion Control Program website: www.wsdot.wa.gov/Environment/WaterQuality/ErosionControl.htm

6-2.1 Step-by-Step Procedure for Preparing TESC Plans

6-2.1.1 Data Collection and Risk Analysis

Collect site-specific data on soil, precipitation, topography, drainage patterns/off-site water, groundwater, sensitive areas on or near the site, vegetated areas, and other relevant project characteristics. Evaluating the risks associated with each of these factors is necessary to select the appropriate BMPs and determine the level of effort needed to address the 12 TESC elements. Most high-risk projects involve more than 5 acres of soil disturbance, discharge to state waters within 300 feet of the project, and meet at least three of the following four characteristics:

- More than 50% of the site consists of soils in Hydrologic Groups C and D. This information is obtained from Natural Resource Conservation Service (NRCS) county soil surveys.
- The project involves wet-season—October through April—work or lasts more than one year.
- Cut/fill slopes exceed more than 50 feet in length.
- There are active seeps or there is shallow groundwater on the project site.

Information on collecting data and analyzing risk for each factor is provided below. The information gathered should be explained in the TESC plan narrative and shown on the plan sheets.

1. Soils

The proportion of sand, silt, and clay particles in the soil determines soil texture. Soil texture affects the erodibility of the soil, how quickly the particles settle out of runoff, and the amount of infiltration that will occur at a site. Information on soil texture can be obtained for any given project from several sources, including geotechnical reports/soil boring logs, jar testing, on-site evaluation, and NRCS soil survey reports for individual counties.

The *Construction Site Erosion and Sediment Control Course Manual* and Chapter 4 (Hydrologic Analysis) of this manual provide guidelines for determining soil-related risks, including the methods listed above. Additional WSDOT resources include Region Environmental, Maintenance, and

Landscape offices, Region Materials Engineers, and the HQ Erosion Control Program.

2. Precipitation

The frequency, intensity, and duration of rainfall events affect the potential for erosion on a site. All three factors must be accurately evaluated to assess the potential for erosion.

The *Hydraulics Manual* (Chapter 2, Appendix 2-3) contains isopluvial maps for mean annual precipitation, design storm events, and mean annual runoff that can all be used to get a general idea about rainfall patterns in any given part of the state.

The Western Regional Climate Center website has statistical information on precipitation, temperature, and several other climatic measurements for over 200 sampling stations throughout the state. This website (which can be accessed at: www.wrcc.dri.edu/summary/climsmwa.html) includes tabular and graphical information as well as interactive probability-graphing capabilities. This information is vital to the timing and phasing of projects to minimize erosion potential.

3. Topography

The size, gradient, and stability of slopes in the project work area should be evaluated to assess potential risks during construction. The potential for erosion increases exponentially with increasing slope length and gradient, because runoff travels faster, with more erosive energy. Higher velocity runoff forms rills and gullies that concentrate erosive flows and energy even further. Whenever slopes are created with Hydrologic Group C or D soils, there is an increased risk of large slope failures, especially when silt content exceeds 30%. All soil types, regardless of composition, are vulnerable to rapid rill and gully erosion when concentrated flows are not diverted away from slopes. In addition, groundwater seepage greatly increases the potential for slope failures with all soil types.

Risk analysis for Element 4, Install Sediment Control, should include information pertaining to the site topography. Identify areas that can be taken advantage of to reduce the risk of turbid water discharges. Closed depressions, flat areas, or gently sloped/heavily vegetated areas can disperse and infiltrate runoff and thereby eliminate or greatly reduce the risk of turbid water discharges during construction. Dispersion, infiltration, and bioinfiltration areas must be labeled on the TESC plan sheets and visually inspected at least once per day when in use to ensure they are functioning as intended. Flow to these areas must be controlled to encourage complete infiltration and avoid discharges whenever possible.

4. Drainage Patterns/Adjacent Areas

Off-site water that runs onto a project can cause tremendous damage because the contributing area may generate stormwater volumes that far exceed the capacity of the on-site stormwater conveyance and treatment BMPs. Some of WSDOT's largest erosion-related cost overruns and fines in past years were related to off-site water entering construction sites.

Off-site water sources may include natural sheet flow from neighboring facilities; permitted or illicit stormwater outfalls from neighboring buildings and parking lots; groundwater seeps; neighboring construction projects; or unmapped seasonal drainages. The risk of site damage from off-site flows is especially high if off-site water crosses slopes because slope cover BMPs cannot adequately protect a slope from concentrated runoff. Off-site water should be handled separately from stormwater generated on the site.

Whenever possible, off-site stormwater should be diverted around the site in a lined channel or pipe to prevent erosion and commingling with on-site stormwater. Diverted flows will be redirected to the natural drainage location at or before the property boundary and discharged in a manner that does not cause downstream erosion.

Take the following actions to evaluate the potential for off-site stormwater problems:

- When prescribing temporary measures, refer to the Hydraulic Report to quantify the potential for off-site water
- Consult maintenance personnel to determine drainage patterns and general volumes
- Visit the site during a rainstorm and confirm runoff patterns

5. Groundwater

Seasonably high groundwater levels affect stormwater infiltration and timing of construction. The groundwater levels can usually be determined from the geotechnical survey of the site. County soil surveys also provide general information on groundwater levels, including the seasonality of high water tables. Groundwater levels can fluctuate greatly throughout the year; data from winter (wet season) is the most important to determine the level of risk associated with groundwater.

The probability of intercepting damaging groundwater seeps and springs can be evaluated using geotechnical reports, county soil maps, and on-site field evaluations. To further evaluate project risk, contact WSDOT project engineers for information about past projects in the area to determine whether problems were encountered with the seasonality, quantity, treatment, and disposal of groundwater.

6. Sensitive Areas

Stream and wetland boundaries must be delineated in the field and shown with their buffer zones on the plan sheets. A sediment control BMP (such as silt fence, wattle, compost berm or sock, or vegetated buffer strips) should always be placed between the site and downslope of sensitive areas.

Ditched streams and other sensitive areas shall never be considered for dispersion, infiltration, and bioinfiltration activities. Dispersion and infiltration in Critical Aquifer Recharge Areas will not be allowed in areas with less than 5 feet between the ground surface and the seasonal high groundwater table, as identified in the Geotechnical Report.

When developing the TESC plan, always refer to environmental studies and permits for the project if they have been prepared/completed. These documents often provide an assessment of how sensitive the receiving waters are and specify measures that are required as conditions of the project. Region environmental staff should be consulted if the studies and permits are not yet completed.

7. Vegetation Preservation/Utilization

Whenever vegetation is preserved, the potential for erosion is reduced and potential sediment treatment areas remain available for use throughout construction. Accordingly, clearing limits are set to minimize the removal of vegetation. Preserved vegetated areas can be highly effective for dispersing and infiltrating runoff. Label the existing vegetation that will be protected on the TESC plan sheets.

8. Existing Encumbrances

Check for existing encumbrances, such as utilities, wells, or drain fields, to ensure the TESC plan identifies them, protects them from erosion impacts, and addresses any potential erosion risks.

9. Timing and Duration

During the design phase, it is often impossible to know the timing and duration of a project. As timing is often dependent on funding, permitting, and other issues, and duration varies with contractors and weather conditions, most TESC plans should be prepared assuming worst-case conditions for timing and duration.

6-2.1.2 BMP Selection/TESC Elements

For comprehensive descriptions of individual BMPs, see Appendix 6A.

Using the information obtained in Step 1 (below), determine the applicability and level of effort needed for each of the 12 TESC elements, in order to select appropriate BMPs for

each. All must be considered and included in the TESC plan unless site conditions render an element unnecessary and the exemption is clearly justified in the narrative of the TESC plan.

1. **BMP Selection**

The three categories of BMPs that exist include *design*, *procedural*, and *physical*. A combination of all three is needed to create effective TESC plans. Each BMP type is described in detail below.

The priority in selecting BMPs should be to prevent erosion, rather than to treat turbid runoff that results from erosion. This is accomplished by maximizing the use of design and procedural BMPs prior to prescribing physical BMPs. The effectiveness of physical BMPs is limited if proper consideration is not first given to design and procedural BMPs.

□ **Design BMPs**

A project design that minimizes erosion risk can greatly reduce complications, both during and after construction. All possible measures should be taken to minimize clearing and grading that expose soil to erosion. For example, projects should be designed to integrate existing land contours as much as possible and minimize the gradient and continuous lengths of slopes. Drainages should be designed to convey water generated both on and off the site to infiltrate and flow away from the disturbed areas as much as possible.

□ **Procedural BMPs**

How and when a project is built can greatly affect the potential for erosion. Construction sequencing should minimize the duration and extent of soil disturbance. Whenever possible, major soil-disturbing activities should occur in phases to minimize exposed areas. Likewise, major grading operations should be limited to the dry season. Installation of sediment control BMPs prior to grading operations is one of the most important procedural BMPs.

□ **Physical BMPs**

Physical BMPs include all erosion and sediment control measures that are installed after all possible design and procedural BMPs have been considered. The *Standard Specifications*, Section 8-01, provides guidance on the installation, inspection, and maintenance of physical BMPs. More detailed information on physical BMPs is provided in Appendix 6A and in the *Construction Site Erosion and Sediment Control Course Manual*.

2. TESC Elements

The 12 TESC elements are described below. All elements must be considered and included in the TESC plan, unless site conditions render an element unnecessary and the exemption is clearly justified in the narrative of the TESC plan. Common design and procedural BMPs are described for each element, followed by a list of physical BMPs, if applicable.

□ *TESC Element 1: Mark Clearing Limits*

Prior to land-clearing activities, mark all clearing limits on the plan and in the field with high-visibility fences, to protect sensitive areas and their buffers (including vegetation to preserve), as well as adjacent properties. Retain duff layer, native topsoil, and existing vegetation in an undisturbed state to the maximum extent practicable.

PHYSICAL BMPS

- Preserving natural vegetation
- Buffer zones
- High visibility fence

□ *TESC Element 2: Establish Construction Access*

Access points shall be stabilized with a pad of quarry spalls, crushed rock, or equivalent BMP, per Standard Specification 8-01.3(7) and the Standard Plans. Install stabilized construction access points prior to major grading operations. Limit access points to the fewest number possible—only one, whenever feasible. Whenever practicable, slope entrances downward into the site to reduce track-out of sediments onto the roadway. If sediment is tracked off-site, roads are to be cleaned thoroughly at the end of each day or more frequently if necessary. Sediment should be removed from roads by shoveling or sweeping, and removed sediment should be transported to a controlled disposal area. If the stabilized construction entrance is not effective in preventing sediment from being tracked onto roads, a tire wash must be used and the wash-water must be discharged to a separate on-site treatment system, such as closed-loop recirculation or land application, or discharged to a sanitary sewer (if allowed by individual permit). Street washing is only allowed after sediment is removed from the street. If streets are washed with water, wash-water must be treated prior to discharge.

PHYSICAL BMPS

- Stabilized construction entrance
- Construction road stabilization
- Street cleaning
- Tire wash

□ ***TESC Element 3: Control Flow Rates***

Protect downstream properties and waterways from erosion by preventing increases in the volume, velocity, and peak flow rate of stormwater runoff from the site during construction. Install the permanent sediment control facilities to provide flow control as early in the construction process as feasible. Protect infiltration facilities from siltation during the construction phase.

Install retention/detention facilities as one of the first steps in grading, for use as infiltration or sedimentation facilities prior to mass grading and the construction of site improvements. Design sediment ponds and traps using criteria contained in Section 4-3.3 for western Washington or Section 4-4.3 for eastern Washington. Design drainages to account for both on- and off-site water sources. Use vegetated areas that are not identified as wetlands or other sensitive features to infiltrate and dispose of water whenever possible, and mark those areas on the TESC plan sheets.

Nonstormwater (dewatering, line flushing) discharges must also be controlled to protect downstream properties. When nonstormwater discharges are routed through separate storm sewer systems, the flow rate must be controlled to minimize scouring and flushing of sediment trapped in the system.

PHYSICAL BMPS

- Temporary sediment pond
- Sediment trap
- Stormwater infiltration

□ ***TESC Element 4: Install Sediment Controls***

Install sediment control BMPs prior to soil-disturbing activities. Prior to leaving a construction site or discharging to an infiltration facility, concentrated stormwater runoff from disturbed areas must pass through sediment ponds or traps. Sheet flow runoff must pass through sediment control BMPs specifically designed to remove sediment from sheet flows such as filter berms, vegetated filter strips, or silt fencing. Because maintaining sheet flows greatly reduces the potential for erosion, runoff should be maintained and treated as sheet flow whenever possible.

PHYSICAL BMPS

- | | |
|----------------------|--|
| ➤ Silt fence | ➤ Wattle |
| ➤ <u>Check dam</u> | ➤ Temporary sediment pond <u>or trap</u> |
| ➤ Straw bale barrier | ➤ Street cleaning |

- Surface roughening
- Inlet protection
- Preserving natural vegetation
- Vegetated filter strip
- Filter berm (gravel, wood chip, or compost)
- Level spreader
- Outlet protection
- Portable storage water tanks
- Stormwater chemical treatment*
- Construction stormwater filtration*

*All TESC plans, including stormwater chemical treatment, whether originally planned or added after construction begins, must notify both region and Headquarters water quality programs.

□ **TESC Element 5: Stabilize Soils**

Stabilize all exposed and unworked soils by applying effective BMPs that protect the soil from wind, raindrops, and flowing water. Selected soil stabilization measures must be appropriate for the time of year, site conditions, estimated duration of use, and the water quality impacts that stabilization agents may have on downstream waters or groundwater.

Construction activity, including equipment staging areas, material storage areas, and borrow areas that are included in WSDOT’s National Pollutant Discharge Elimination System (NPDES) permit for the project, must be stabilized and addressed in the TESC plan as well.

Soil stockpiles are especially vulnerable to slumping when saturated and must be stabilized and protected with sediment-trapping measures. Plastic may be necessary on silty stockpiles, as it is the only BMP that can prevent soil saturation. Stockpiles should be located away from storm drain inlets, waterways, and drainage channels where possible.

In western Washington, cover exposed soil that is not being worked—whether at final grade or not—within the following time limits, using approved soil cover practices:

October 1 through April 30	2 days maximum
May 1 through September 30	7 days maximum

In eastern Washington, exposed soil that is not being worked—whether at final grade or not—must be covered within the following time limits, using approved soil cover practices:

July 1 through September 30	10 days
October 1 through June 30	5 days

In the Central Basin region of eastern Washington (areas receiving 12 inches or less of annual rainfall), exposed soil that is not being worked—whether at final grade or not—must be covered within the

following time limits, using approved soil cover practices. For precipitation maps, see: www.wsdot.wa.gov/Design/Hydraulics/

July 1 through September 30 **30 days**
October 1 through June 30 **15 days**

If any portion of the project lies in areas that receive more than 12 inches of annual precipitation, follow the soil coverage time limits for eastern Washington, not for the Central Basin. (Contact the Region Hydraulics Office staff to confirm average annual rainfall.)

Expose no more soil than can be covered within the above time limits. Construction activities should never expose more erodible earth than the amounts shown below for the specified locations.

Area	Date	Location
17 Acres	April 1 – October 31	East of the Summit of the Cascade Range
	May 1 – September 30	West of the Summit of the Cascade Range
5 Acres	November 1 – March 31	East of the Summit of the Cascade Range
	October 1 – April 30	West of the Summit of the Cascade Range

PHYSICAL BMPS

- Preserving vegetation
- Temporary mulching
- Soil binding using polyacrylamide*
- Placing erosion control blanket
- Placing compost blanket
- Placing plastic covering
- Seeding and planting
- Gravel base
- Mechanically Bonded Fiber Matrix
- Sodding
- Check dam**
- Wattle**
- Surface roughening***
- Stabilized construction entrance
- Construction road stabilization
- Dust control BMPs
- Bonded Fiber Matrix

*While polyacrylamide alone does help stabilize soils, using it in conjunction with mulch provides more protection for disturbed soil.

**Check dams and wattles alone do not stabilize soils. These BMPs should be used in conjunction with other soil stabilization BMPs.

***Surface roughening alone does not provide soil stabilization. Another BMP should be used in conjunction with surface roughening to protect the soil from raindrop impacts. It must be performed prior to seeding, per the *Standard Specifications*.

□ **TESC Element 6: Protect Slopes**

Design and construct cut-and-fill slopes in a manner that will minimize erosion by (1) reducing continuous length and steepness of slopes with terracing and diversions, (2) reducing slope steepness, and (3) roughening slope surfaces, considering soil type and its potential for erosion (such as track walking). In addition, all soil must be protected from concentrated flows through temporary conveyances such as diversions and pipe slope drains. If flow is exclusively surface water, use the design criteria contained in Section 4-3.3 for western Washington or Section 4-4.3 for eastern Washington.

If flow is from seeps or groundwater, use your best professional judgment in consultation with the Region Materials Engineer (RME) when sizing slope drains. Conveyances exceeding a 10% slope should have a solid lining.

To capture sediment and runoff when cutting trenches, place excavated soil on the uphill side of the trench (when consistent with safety and space considerations).

Check dams should be placed at regular intervals (see the *Standard Plans*) within constructed channels that are cut down a slope.

PHYSICAL BMPS

- Channel lining (riprap, grass)
- Temporary pipe slope drain
- Temporary curb
- Interceptor dike and swale
- Physical BMPs listed under TESC Element 5 (with the exception of stabilized entrance and road stabilization)
- Subsurface drains
- Level spreader
- Live fascines
- Gradient terraces

□ **TESC Element 7: Protect Drain Inlets**

Protect all operable storm drain inlets from sediment with approved inlet BMPs.

PHYSICAL BMPS

- Inlet protection (above/below grate and grate covers)
- Check dam

□ **TESC Element 8: Stabilize Channels and Outlets**

All temporary conveyance channels should be designed, constructed, and stabilized to prevent erosion. Use the design criteria contained in Section 4-3.3 for western Washington or Section 4-4.3 for eastern Washington.

Stabilization, including armoring material, adequate to prevent erosion of outlets, adjacent stream banks, slopes, and downstream reaches shall be provided at the outlets of all conveyance systems.

PHYSICAL BMPS

- Channel lining (riprap, grass)
- Level spreader
- Check dam
- Temporary seeding and planting
- Erosion control blanket
- Sodding
- Outlet protection

□ **TESC Element 9: Control Pollutants**

All pollutants, including construction materials, waste materials, and demolition debris, must be handled and disposed of in a manner that does not cause contamination of stormwater. Methods for controlling nonhazardous pollutants must be described in the TESC plan. Wood debris may be chopped and spread on-site. Application of fertilizers and other chemicals should be conducted in a manner and at application rates that will not result in loss of chemicals to stormwater runoff. Manufacturers' label requirements for application rates and procedures must be followed.

Methods for controlling pollutants that can be considered hazardous materials, such as hydrocarbons and pH-modifying substances, must be described in the contractor's SPCC plan. The plan must be prepared to meet Standard Specification 1.07.15(1) and the Washington State Department of Ecology's (Ecology's) standards as described in WSDOT SPCC Plan Preparation Instructions and Spill Plan Reviewers Protocols:

☞ www.wsdot.wa.gov/Environment/HazMat/SpillPrevention.htm

Stormwater or groundwater that has come into contact with curing concrete must be sampled to ensure water quality standards are not violated. (See water quality monitoring protocols in Section 6-8 for sampling information). Process water (for example, concrete washout, slurry water, and hydrodemolition) must be contained and cannot be discharged to waters of the state under the NPDES General Construction Permit. Contact region environmental staff and the HQ Environmental Services Office for more information on disposing of high pH water. WSDOT Headquarters has created a specific GSP, Treatment of pH for Concrete Work:

☞ www.wsdot.wa.gov/eesc/design/projectdev/GSPS/egsp8.htm

□ ***TESC Element 10: Control Dewatering***

When groundwater is encountered in an excavation or other area, control, treat, and discharge it as described in Standard Specification 8-01.3(1)C.

□ ***TESC Element 11: Maintain BMPs***

A Certified Erosion and Sediment Control Lead (CESCL) shall inspect BMPs per Standard Specification 8-01.3(1)B to ensure they perform their intended function properly until the Project Engineer determines that final stabilization is achieved. Final stabilization means completion of all soil-disturbing activities and establishment of a permanent vegetative cover or permanent stabilization measures (such as riprap) to prevent erosion. Temporary BMPs shall be removed within 30 days after final stabilization is achieved.

Maintain BMPs in accordance with Standard Specification 8-01.3(15). When the depth of accumulated sediment and debris reaches approximately one-third the height of the device, the contractor must remove the deposits. BMP implementation and maintenance should be documented in the Site Log Book. Clean sediments may be stabilized on-site if the Project Engineer approves.

□ ***TESC Element 12: Manage the Project***

Apply the following actions on all projects:

- (1) Preserve vegetation and minimize disturbance and compaction of native soil, except as needed for building purposes.
- (2) Phase development projects to minimize the amount of soil exposed at any one time and prevent the transport of sediment from the site during construction.
- (3) Time sediment control BMP installation in accordance with TESC Element 4.
- (4) To minimize erosion, follow soil cover timing requirements and exposure limits in TESC Element 5 and Standard Specification 8-01.3(1). Projects that infiltrate all runoff are exempt from the above restrictions. Individual contract Special Provisions and Project Engineer directives may be more stringent, based on specific location characteristics or changing site and weather conditions.
- (5) The work of utility contractors and subcontractors is coordinated to meet requirements of both the TESC and SPCC plans.

- (6) All BMPs are inspected, monitored, and maintained in accordance with TESC Element 11. Sampling will be conducted to ensure compliance (see Section 6-4 for details).
- (7) The certified Erosion Control Lead is on-site or on-call at all times.
- (8) The TESC and SPCC plans are kept on-site or within reasonable access to the site. Due to the unpredictable nature of weather and construction conditions, the TESC plan is a flexible document that should be modified whenever field conditions change. Whenever inspections and/or monitoring reveal that the BMPs identified in the TESC plan are inadequate due to the actual discharge of or potential to discharge pollutants, the plan must be modified (as appropriate) as soon as possible but within 7 days. Fully implement and maintain BMPs as soon as possible but within 10 days. Most of these updates can be drawn onto the plans sheets. The plan must also be updated whenever there are changes in the project design or in construction methods that could affect the potential for erosion or spills.

6-2.1.3 Schedule

A construction schedule must be provided by the contractor per Standard Specification 8-01.3(1)A. The schedule should specify TESC plan implementation to effectively reduce erosion risks. Include the following in the schedule:

- Installation of perimeter control and detention BMPs prior to soil-disturbing activities.
- Phasing and timing of clearing, grubbing, and grading. Where feasible, work must be phased and timed to minimize the amount of exposed soil at any one time and prevent transport of sediment from the site during construction.
- Application of interim BMP strategies when construction activities interfere with the placement of final-grade BMPs.
- Discussion of how temporary BMPs are to be transitioned into permanent BMPs.
- Implementation of an erosion control inspection and maintenance schedule.

The following is a general schedule guideline for implementing TESC BMPs during construction of a project.

1. Prior to any work on-site, WSDOT verifies:

- The contractor has obtained permits for off-site staging/storage/borrow areas (per NPDES permit requirement S1.C.2). Staging/storage/borrow areas within WSDOT right of way must be included in the TESC plan for the project.
 - The point(s) at which site stormwater runoff and non-stormwater (such as dewatering) leaves the project boundary and enters surface water resources (sampling locations for NPDES permitted projects).
 - Background conditions of water quality for in-water work projects (see Section 6-9.2).
 - Locations where off-site stormwater can enter the project so that it can be diverted around the site, if applicable.
 - Clearing limits.
 - Possible infiltration areas within the right of way (nonsensitive areas) or on neighboring properties—with written permission. These areas should be labeled on the TESC plan sheets as dispersion/infiltration areas.
2. Prior to any soil-disturbing activities, the contractor installs:
 - Storm drain inlet protection BMPs.
 - Perimeter control BMPs (such as construction entrances, silt fences, clearing limit fences, or straw bale barriers).
 - Diversion measures for off-site water, if applicable.
 3. Prior to any other grading activities, temporary sediment/detention ponds are excavated and pond embankments are stabilized or otherwise protected against erosion. Site clearing and grading are phased so that runoff from exposed areas flows through stabilized conveyances to functioning sediment control BMPs.
 4. Major construction excavation begins only after TESC measures for each phase of construction are in place.
 5. Additional erosion and sedimentation control facilities are installed, as needed, throughout construction. These additions must be drawn onto the TESC plan sheets to reflect actual field conditions.
 6. BMPs are maintained, as necessary.
 7. Temporary BMPs are replaced with permanent BMPs, as construction allows.
 8. Once all permanent construction is completed and permanent BMPs are functioning properly, the remaining temporary BMPs are removed in accordance with Standard Specification 8-01.3(16). Temporary BMPs should be removed within 30 days after final stabilization is achieved.

6-2.1.4 Narrative and Plan Sheets

The physical BMPs specified in the narrative section of the TESC plan are shown on the plan sheets. The plan sheets should also show: discharge locations; off-site areas that are covered under WSDOT permits; property lines; North arrow; existing structures and roads; drainage basins and direction of stormwater flow in each drainage basin before and after major grading activities; clearing and grubbing limits; cut-and-fill slope lines; topography; impervious surfaces; sensitive areas; receiving waters; and stormwater treatment areas. The narrative section must include provisions for interim project conditions, not just the final configuration as shown on the plan sheets. The *Plans Preparation Manual* provides more information on plan sheet preparation.

1. Scoping and Budgeting

The scope of a TESC plan includes all phases of construction. Each phase of a construction project needs to be included in the risk analysis and evaluation effort. Intermediate site configurations should be accounted for in the TESC scope because the process of staging requires multiple applications of BMPs. For example, a short-duration project may be scheduled and completed during the dry season, whereas a multiyear project may need soil cover BMPs for each wet season encountered. Inspection and maintenance of BMPs should also be considered in scoping and budgeting, as should the repair or replacement of inadequate or malfunctioning BMPs.

Even with the best planning and risk assessment, there is still an inherent risk associated with each project. For example, groundwater may be encountered where it is not expected, soil conditions are often worse than anticipated, and construction is sometimes delayed into the wet season in western Washington. In addition, low-probability storm events, such as high-intensity rainfall in mid-August, sometimes cannot be avoided. Even after completing a thorough risk assessment, scheduling a project to take advantage of optimum conditions, and incorporating a full range of BMPs, include extra materials and funds in the budget to provide for contingency work.

Budgeting methods for erosion control are not as well developed as for more predictable construction activities. Additionally, erosion control overlaps with numerous other construction activities. The budgeting tools described below are intended to help when calculating the cost to install and maintain physical BMPs. Possibly the most accurate method for calculating a TESC budget is to consult with technical personnel and specialists. Consultation with WSDOT personnel with experience on similar projects is recommended to confirm cost estimates for anticipated/selected BMPs.

2. Cost-Based Estimate

Costs can be calculated from the labor and materials costs for individual items. This method can be time consuming; however, it is the only method available for many of the newer TESC products.

3. Bid-Based Estimate

The HQ Design Office has some very useful tools for making bid-based estimates. The UnitBid Analysis and Standard Item Table (www.wsdot.wa.gov/biz/contaa) can be used to view per-unit costs for specific standard bid items on past WSDOT projects. This method can quickly provide a price range for most common erosion control bid items.

4. Construction Contract Information System

The HQ Construction Office maintains the Construction Contract Information System (CCIS), which contains cost information from past projects. This database can be used to estimate future erosion control costs. If a project is being built in an area with a history of erosion challenges, the designer can query the database to view how much was estimated under the line items for Water Pollution Prevention/Erosion Control and other commonly used TESC BMPs versus how much was actually spent. For instance, on some state routes and on some project types, WSDOT consistently pays more than it estimates for erosion control. If the erosion control costs in an area are consistently greater than the estimates, consult the construction offices that experienced the cost overruns. Ask what factors caused the overruns, and incorporate extra measures into the erosion budget and the TESC plan to address problems and prevent or reduce such overruns on the upcoming project. WSDOT staff should contact their local help desk or workstation support personnel to obtain access to CCIS.

6-2.2 Contracting

The ability to enforce provisions in the TESC plan is directly tied to the contract. Contracts must be written to ensure all 12 TESC elements are addressed throughout construction. The contractual tools for ensuring the plan is properly enforced include the *Standard Specifications for Road, Bridge, and Municipal Construction (Standard Specifications)*, statewide and region-specific GSPs, Special Provisions, and erosion control plans in the *Standard Plans for Road, Bridge and Municipal Construction (Standard Plans)*.

Revisions are regularly made to the erosion control specifications in the *Standard Specifications* to do a better job of meeting the 12 elements within a TESC plan. However, in some cases they must be supplemented with GSPs or Special Provisions to ensure issues concerning erosion control are addressed in the contract language.

GSPs or Special Provisions should be prepared whenever the *Standard Specifications* do not address the specific needs of a project. Such provisions may involve limiting earthwork in the wet season, timing of pond installation, or requiring specific products. GSPs and Special Provisions have been written for many common erosion problems and can be pulled from existing libraries. The statewide library for GSPs and Special Provisions is provided on the HQ Design Office website: www.wsdot.wa.gov/design/projectdev/

Some regions also have their own libraries of regional GSPs that can be accessed by contacting the Region Plans Office. If there is no suitable provision, one must be written. Staff within design, construction, and environmental offices can often help and should be consulted.

6-3 Spill Prevention Control and Countermeasures Plan

A Spill Prevention Control and Countermeasures (SPCC) plan is required on all projects in order to prevent and minimize spills that may contaminate soil or nearby waters. The plan is prepared by the contractor as a contract requirement and is submitted to the Project Engineer prior to the commencement of any on-site construction activities. For further information, refer to Standard Specification 1-07.15(1).

The Hazardous Materials and Solid Waste Program provides online guidance to contractors for preparing SPCC plans and provides training to WSDOT staff for reviewing an SPCC plan to ensure compliance with the following required elements:

- Site information and project description
- Spill prevention and containment
- Spill response procedures
- Standby on-site material and equipment requirements
- Reporting information
- Program management
- Plans to contain preexisting contamination, if necessary
- Equipment for work below the ordinary high water line
- Attachments including a site plan and Spill and Incident Report forms

SPCC plans are required to be project/site specific. When contractors write the SPCC plan in coordination with key WSDOT project staff, the plan can ensure:

- All pollutants are handled in a manner that does not cause contamination of stormwater.

- Cover, containment, and protection from vandalism are provided for all materials that, if spilled, would pose an immediate risk to surface waters or groundwater.
- Maintenance and repair of heavy equipment are conducted using spill prevention measures such as drip pans and, if necessary, cover.
- Contractors follow manufacturers' recommendations for applying fertilizers and herbicides, to protect runoff water quality.
- Materials that modify pH, such as cement, concrete, kiln dust, fly ash, cement grindings, and cement wash-water, be managed to prevent contamination of runoff.

Additional SPCC guidance is available at:

www.wsdot.wa.gov/Environment/HazMat/SpillPrevention.htm

6-4 Water Quality Sampling and Reporting Procedures

The following procedures have been developed to document compliance with local, state, and federal permit conditions. These procedures are also used to evaluate the effectiveness of BMPs.

All projects with greater than 1 acre of soil disturbance—except federal and tribal land—that may discharge construction stormwater to waters of the state are required to seek coverage under the NPDES Construction Stormwater General Permit. Sampling guidance for meeting permit requirements can be found in Section 6-8.

Sampling guidance for in-water work projects that are issued a 401 Certification or those working under the Water Quality Implementing Agreement is in Section 6-9.

Projects that require additional permit conditions should contact region environmental and HQ Environmental Services Office staff to incorporate additional sampling parameters into these protocols.

6-5 Standard Sampling Procedures

1. Sampling Equipment

All regions use the following water quality sampling equipment. This equipment was selected for the purpose of legal compliance and should be maintained to document the project conditions and legal records of WSDOT construction activities.

Conditions/Procedures	Sampling Equipment
Turbidity	Hach Model 2100P portable turbidimeter with sampling bottles
pH and temperature	Hach Model SensION portable pH meter or HQ11D pH meter
Water sampling	Rod & cup (12-foot extendable)
Rain measurement	Gage – Tru-Check brand or equivalent installed on-site
Field observations	Field notebook/recording equipment

Company	Product	Approximate Cost
Hach Company* (970) 669-3050 ☎ www.hach.com	<ul style="list-style-type: none"> • 2100P Turbidimeter • SensION1 pH Meter • HQ11D pH Meter <u>with pH301 liquid-filled pH electrode</u> 	<p style="text-align: center;">\$850</p> <p style="text-align: center;">\$500</p> <p style="text-align: center;">\$500</p>

(*or any major scientific supply distributor)

2. Equipment Calibration

Calibrate equipment according to manufacturers' recommendations and specified schedules. Calibration frequency must follow the manufacturers' recommendations, at a minimum, for data to be legally defensible. Additional calibrations should be performed immediately if data appear suspect.

3. Field Equipment Checklist

- Sampling cup/rod or hip waders
- Turbidity equipment (check batteries and sampling supplies)
- pH equipment (check batteries and sampling supplies)
- Distilled water for rinsing equipment
- Long survey stakes, hammer, and marking pen (initial set-up only)
- Rain gage
- WSDOT-approved safety vest and hardhat
- Camera
- Field notebook or data sheets for recording sampling data and field conditions. Data sheets are available at:
☎ www.wsdot.wa.gov/Environment/WaterQuality/ErosionControl.htm
- Cellular phone and contact phone numbers

4. **Sampling Station Setup**

When setting up sampling stations:

- Mark all sampling station locations with clearly labeled survey stakes.
- Photograph each sampling station for future reference and reporting. Picture(s) should show a good relationship between the project, the sampling station, and the surrounding environment.
- If sampling outside WSDOT right of way, survey stake locations should be within WSDOT right of way with direction and distance labels to the exact sampling point locations. Record the exact sampling point location in the field notebook and the TESC plan.

5. **Create Base/Site Map**

Develop a relatively small-scale map depicting the project, sampling locations, and major water, land, and road characteristics. Keep the map in the Site Log Book so that other staff can understand the locations and access the sampling stations. Monitoring locations should also be drawn onto the TESC plan sheets.

6. **Sampling Information**

The following information is recorded in the field notebook (or on the data recording sheets) for each sampling event:

- Date, time, and location of the sample
- Project name and contract number
- Name(s) of personnel who collected the sample
- Amount of rainfall in the last 24 hours
- Field conditions (such as weather, temperature, pertinent construction activities, and any prior disturbance of the water body)
- Testing results for measured parameters
- Date and time of the last calibration of sampling equipment
- Notes summarizing (among others) critical activities, unusual conditions, corrective actions, and whether or not photographs were taken as supporting documentation

7. **Sampling Procedures**

The following sampling procedures must be used:

- In-water work: Sampling begins at the downstream station first, followed by the upstream location, to avoid contamination. Testing of samples should occur at the designated sampling station whenever possible.
- Collect samples that are representative of the flow and characteristic of the discharge. Use the sampling rod if necessary.
- Fill the sampling bottle—downstream—at least once prior to collecting the sample, to remove possible contaminants. Invert the sample bottle to resuspend particulates prior to turbidity testing.
- pH sampling should occur prior to turbidity testing, as temperature affects pH.
- Follow the manufacturers' recommendations for equipment operations.

6-6 Office Data Recording and Analysis

WSDOT has developed a Water Quality Monitoring Database (see Section 2-3.2.1) that all projects must use to input water quality data. For in-water work projects and other non-NPDES General Construction permitted projects, the database automatically calculates water quality standards based on the receiving water body and noncomplying events are flagged, prompting the user to initiate Environmental Compliance Assurance Procedures (ECAP). For projects with NPDES General Construction Permits, the database provides a field to input outfall sample values. For a brief training, contact region environmental personnel or the Statewide Erosion Control Coordinator at the HQ ESO, 360-570-6649.

6-7 Reporting Sampling Results and Compliance Issues

The NPDES Construction Stormwater General Permit requires that turbidity data be submitted monthly for all projects with greater than 5 acres of soil disturbance after October 1, 2006 (the threshold drops down to 1 acre on October 1, 2008). The HQ Environmental Services Office will batch send data to Ecology monthly via the Water Quality Monitoring Database. Therefore, all projects with NPDES General Construction permits must enter water quality data into the database as data are collected.

Data collected during in-water work projects, on projects covered under Individual NPDES permits, or those discharging to 303(d) or TMDL-listed water bodies must also be entered into the Water Quality Monitoring Database, but the data must be reported to resource agencies by project office staff. The Water Quality Monitoring database can generate graphs of water quality data showing both upstream and downstream data, along with the state standard.

If a turbidity or pH sample is out of compliance with water quality standards (in-water work) or exceeds the benchmark values (General NPDES permit monitoring), ECAP should be filed as soon as possible. Recording the data into the Water Quality Monitoring database is not the same as filing ECAP. There is another process for reporting a noncompliance event. For more information on ECAP, go to: www.wsdot.wa.gov/NR/rdonlyres/7124F20E-9159-4737-9C3B-C1FB2896633A/0/ECAP.pdf

Additional Project Water Quality Sampling

If construction stormwater will be discharging to a 303(d) or a TMDL-listed water body, or if there is an NPDES Individual Stormwater Permit that requires additional sampling, contact region environmental personnel and the HQ Environmental Services Office at 360-570-6649 or 360-570-6648 for guidance on implementation.

If a project chooses to monitor any pollutants more frequently than required by these protocols, the data must be reported to Ecology per a requirement of the NPDES Construction Stormwater General Permit. Section 6-8 of WSDOT's water quality monitoring protocols is designed to meet the NPDES permit requirements, and region environmental and HQ Environmental Services Office staff should be contacted if additional sampling will be performed.

Enter **all water quality data** into the Water Quality Monitoring Database, regardless of which permit or regulatory program the project is under. Data submitted for the NPDES Construction Stormwater General Permit will be reported to Ecology through the HQ ESO Stormwater and Watersheds Program. Project offices or region environmental support staff **must directly submit** data collected for all individual NPDES, 401 Cert, TMDL, or 303(d)-listed water bodies to the appropriate Ecology contact, per permit requirements.

6-8 NPDES General Construction Permit Sampling Procedures

All project water quality monitoring forms, maps, and pictures of sampling stations must be kept in the Site Log Book, along with copies of the contractors' inspection reports. The Site Log Book must be kept on-site to provide easy access for compliance inspections.

Prior to water quality sampling in the field, the responsible WSDOT personnel must perform the following procedures:

1. Review Important Project Information and Assess Risk

Review project maps, project definition, and schedule to understand when and where construction activities have the greatest potential to impact specific water quality parameters.

Projects that require turbidity sampling are as follows:

Any WSDOT projects that disturb 5 acres or more of soil (1 acre or more as of October 2008) when runoff from construction activities discharges to surface waters of the state or to a storm sewer system that drains to surface waters of the state. It is not necessary to sample stormwater if soil disturbing activities have not begun yet (for example, prior to breaking ground) or on portions of the site undisturbed by construction activity (such as areas of native vegetation that will not be disturbed).

Standard activities and project conditions that require pH sampling are as follows:

- **Any WSDOT project that disturbs 1 acre or more and involves any of the following:**
 - (1) Greater than 1000 cubic yards of poured concrete curing simultaneously during a less-than-30-day period
 - (2) Greater than 1000 cubic yards of recycled concrete are crushed on-site
 - (3) The use of soils that are amended with cement or kiln dust where stormwater from the affected area drains to surface waters of the state or to a storm sewer system that drains to surface waters of the state

2. Establish Sampling Locations

Establish sampling locations to determine construction stormwater outfall water quality conditions. Sites with multiple outfalls or stream crossings may require numerous sampling stations.

Sampling is required at all discharge points where stormwater or non-stormwater (such as dewatering water) is discharged off-site or to state waters within the site. It is not necessary to sample stormwater if soil-disturbing activities have not yet begun (for example, prior to breaking ground) or on portions of the site undisturbed by construction activity (such as areas of native vegetation that will not be disturbed). Locate and clearly mark in the field sampling points according to the following criteria:

- **Discharge water quality.** Locate the sampling point at all locations where stormwater or non-stormwater is drained or discharged from the project boundary or into any on-site stormwater conveyance system or surface waters. The sample should be collected before the construction stormwater enters the receiving water body. This sample should be evaluated for possible turbidity benchmark value exceedances, and steps identified in Procedure 3 below should be followed if benchmark value is exceeded. In cases where water directly discharges from the site through a traditional stormwater treatment BMP like a pond, sampling will occur at the outlet of the BMP. In cases where WSDOT

provides additional treatment via dispersion within adjacent properties, discharges will be sampled after the additional treatment is provided.

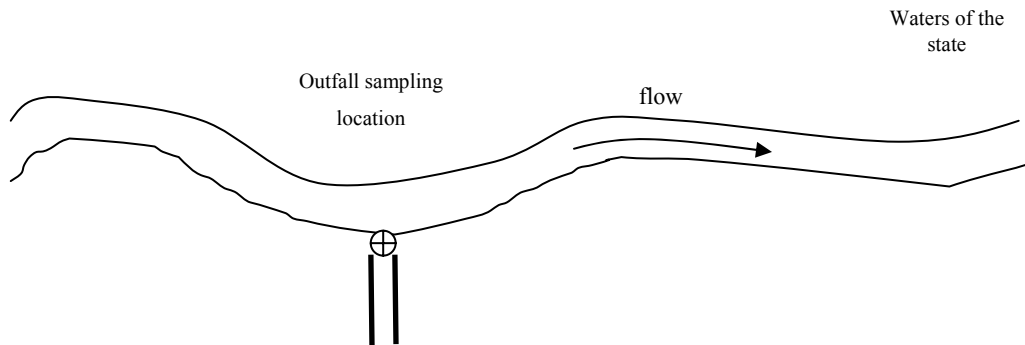

Figure 6-5.1. General layout of NPDES General Construction Permit water quality sampling location.



Examples of typical stormwater discharge locations where the person monitoring would potentially take stormwater samples.
Top left: Stormwater catch basin.
Top right: Stormwater discharging from a pipe outlet.
Bottom left: Stormwater discharging over the top of silt fence into a ditch.

3. Establish Turbidity Sampling Schedule

Establish a sampling schedule to ensure monitoring is conducted during the high-risk periods.

Follow the schedule for turbidity sampling.

- **All WSDOT projects that disturb 5 acres or more of soil (1 acre or more as of October 2008).** Sample at least once every calendar week when there is a discharge of stormwater or non-stormwater (such as dewatering water or groundwater) from the site to satisfy NPDES stormwater permit requirements. Authorized nonstormwater discharges include, but are not limited to, draining of ponds, vaults, or footings and flushing of water lines. If the sample or visual observations indicate the potential for a water quality violation, perform contingency sampling (see section below on contingency sampling). Samples must be representative of the flow and characteristics of the discharge. When there is no discharge during a calendar week, sampling is not required. Sampling is not required outside normal working hours or during unsafe conditions (a note should be written with a brief description of why a sample was not collected). Contact the HQ Environmental Services Office at 360-570-6649 or 360-570-6648 for guidance on sampling during temporary suspension of construction.

Turbidity Benchmark Values

Benchmark values were created as indicators of properly functioning BMPs and are not discharge limitations. Discharges from construction sites less than 25 NTU are considered not likely to cause an exceedance of water quality standards under most conditions, and BMPs are thought to be functioning well. Construction site discharges between 26 and 249 NTU are more likely to cause an exceedance of water quality standards, and may indicate that the TESC plan has not been well implemented or BMPs are not functioning properly. A discharge greater than 250 NTU is likely to cause an exceedance of water quality standards under most conditions and typically indicates the TESC plan has not been well implemented and BMPs are not functioning properly. Therefore:

- a. If an outfall sample has a value greater than 25 NTU, but less than 250 NTU:
 - i. Review the TESC plan and make appropriate revisions within 7 days of the discharge that exceeded the benchmark; and
 - ii. Fully implement and maintain the BMPs as soon as possible, but within 10 days of the discharge that exceeded the benchmark, and document in the Site Log Book. If installation of necessary treatment BMPs is not feasible within 10 days, Ecology may approve additional

time when an extension is requested by a permittee within the initial 10-day response period.

- b. If an outfall sample has a value of 250 NTU or greater:
 - i. Notify Ecology by phone within 24 hours (file ECAP). Discharges of 250 NTU or more must be called into Ecology's regional offices, not to the assigned Ecology inspector. Ecology has posted instructions on its web-site regarding how to report high-turbidity discharges:
www.ecy.wa.gov/programs/wq/stormwater/construction/
 - ii. Review the TESC plan and make appropriate revisions within 7 days of the discharge that exceeded the benchmark; and
 - iii. Fully implement and maintain the BMPs as soon as possible, but within 10 days of the discharge that exceeded the benchmark, and document in the Site Log Book. If installation of necessary treatment BMPs is not feasible within 10 days, Ecology may approve additional time when an extension is requested by a permittee within the initial 10-day response period.
 - iv. Collect a sample to document when water quality meets the 25 NTU benchmark for inclusion in the ECAP report. If water quality is not below the 25 NTU benchmark by the end of the workday, then:
 - v. Continue to sample discharges daily until:
 1. Turbidity is 25 NTU (considered not likely to cause an exceedance of water quality standards under most conditions) or lower; or
 2. The discharge stops or is eliminated.

4. Establish pH Sampling Schedule

Follow the schedules for the following project types if conducting pH sampling.

- **Sites with more than 1000 cubic yards of poured concrete curing simultaneously during a less than 30-day period or greater than 1000 cubic yards of recycled concrete are crushed on-site.** The pH monitoring period shall commence when the concrete is first poured and exposed to precipitation and continue at least once per week throughout and after the pour and curing period until stormwater pH is 8.5 or less.
- **Sites with soils amended with cement or kiln dust.** pH monitoring should begin when the soil amendments are first exposed to precipitation and should continue at least once per week until runoff from the area of amended soils complies with the pH benchmark (less than 8.5) or the area is covered.

At least once per week, pH samples should be collected prior to discharge to surface waters from sediment traps or ponds storing runoff from the two areas described above. If the HQ GSP for “Treatment of pH for Concrete Work” is included in the contract, the contractor will be responsible for this monitoring.

Process water or wastewater (nonstormwater) that is generated on-site, including water generated during concrete grinding, truck washout, and hydrodemolition activities, cannot be discharged to waters of the state under the NPDES General Construction Permit. Off-site disposal of concrete process water must be in accordance with Standard Specification 5-01.3(11). Under certain circumstances, however, infiltration of process water may be authorized. As standards for dealing with process water are still evolving, contact region environmental personnel and the HQ ESO Stormwater and Watersheds Program to determine whether infiltration is an acceptable option.

pH Benchmark Values

- a. The benchmark value for pH is 8.5 standard units. Whenever sampling indicates that pH is 8.5 or greater:
 - i. Prevent the high pH water (8.5 or above) from entering storm sewer systems or surface waters; and
 - ii. If necessary, adjust or neutralize the high pH in accordance with the HQ GSP for Treatment of pH for Concrete Work:
www.wsdot.wa.gov/eesc/design/projectdev/GSPS/egsp8.htm

In situations where the GSP does not appear adequate, contact region environmental staff and the HQ Environmental Services Office for more information. These offices can provide additional guidance for extreme situations where neutralizing the high pH water with dry ice or CO₂ sparging may be necessary.

5. Contingency Sampling

Contingency sampling is required if visual observations suggest that turbidity or pH benchmark values may be exceeded. If monitoring confirms that water quality is out of compliance with benchmark values, then additional samples should be taken to determine the duration and magnitude of the event. High pH water (over 8.5) should not be allowed to discharge. Once compliance with benchmark values is achieved (turbidity less than 25 NTU, pH less than 8.5), the project shall return to its standard sampling schedule. Document when samples are back in compliance with standards for inclusion in the ECAP report. Contact the HQ Environmental Services Office, Stormwater and Watersheds Program, if more than three contingency samples are required in one day.

6-9 In-Water Work Monitoring

WSDOT monitors water quality on 20% of in-water work projects and those required by permit conditions. Water quality monitoring must be done in accordance with these protocols and other project permits. If permit requirements vary from these protocols, contact region environmental staff or the HQ Environmental Services Office. Reporting of data must be in accordance with Sections 6-6 and 6-7 of these protocols, along with reporting required by permit conditions.

In-Water Work

Such projects require work below the ordinary high water mark of state water bodies.

1. **Verify Classification and Water Quality Standards**

Verify the classification and water quality standards for potentially impacted water bodies according to state of Washington surface water quality standards (WAC 173-201A). Region environmental personnel should be contacted for assistance if necessary.

2. **Preconstruction Baseline Sampling**

Prior to beginning compliance monitoring, baseline water sampling is required to establish background water quality characteristics. It is important to show the existing water quality conditions both above and below the site prior to construction, as natural streambank erosion or preexisting stormwater outfalls from adjacent properties may cause differences between proposed monitoring points. Whenever possible, baseline monitoring should be performed during a rainstorm no more than one month prior to the start of construction.

One sampling event in which up to three samples can be collected is adequate, unless conditions are variable.

3. **Establish Sampling Locations**

Establish sampling locations to determine background and downstream water quality conditions. Locate and clearly mark in the field sampling points according to the following criteria:

- **Background condition.** Locate background sampling locations where water bodies enter the right of way or 100 feet upstream of construction activities, whichever is closer.
- **Downstream impacts.** Sample 100 feet downstream of the construction activity or at the edge of the right of way, whichever is closer. If a mixing zone is allowed per Ecology's permit, and if the sample collected 100 feet downstream of construction activities is out of compliance with water quality standards, sample at the mixing zone

compliance point designated by Ecology. If out of compliance with water quality standards, file ECAP.

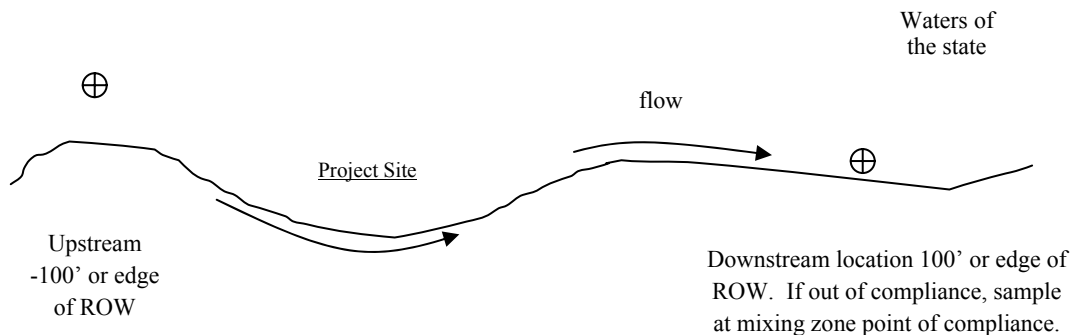

Figure 6-5.2. General layout of typical in-water work sampling locations.

4. Establish Sampling Schedule

Establish a sampling schedule to ensure monitoring is conducted when necessary.

Follow the schedule for conducting turbidity sampling.

- **In-water work.** Sample daily during in-water work activities. One upstream and one downstream sample should be collected after work begins each day. If that sample meets standards and visual inspections reveal no change in water quality throughout the day, no further sampling is required. If work activities change during the day (removing piles in the morning and driving piles in the afternoon), another upstream/downstream sample should be collected after work activities change. If standards are met and visual inspections reveal no change in water quality, then no further sampling is required. If visual inspection reveals a change in water quality, then contingency sampling should occur.

Follow the schedule for conducting pH sampling.

- Whenever water comes in contact with curing concrete, a pH sample must be taken prior to discharge. If the pH is less than 8.5 pH units, the water can be discharged, followed by an upstream and downstream sample to verify that water quality standards are achieved. If water quality standards are not achieved, file ECAP. If the water to be discharged has a pH greater than 8.5 pH units, the water cannot be discharged to waters of the state. This water must be treated, infiltrated, or sent to a sanitary sewer system. Contact region environmental personnel or the HQ Environmental Services Office for more information.

5. Contingency Sampling

If there is a visual change in receiving water turbidity due to work activities or a potential increase in pH, contingency sampling is required. If monitoring confirms that water quality is out of compliance with water quality standards, then additional samples should be taken to determine the duration and magnitude of the event. Once compliance with water quality standards is achieved, the project shall return to its standard sampling schedule. If more than ten contingency samples are collected in one day, contact region environmental personnel or the HQ Environmental Services Office, Stormwater and Watersheds Program.

Best Management Practices

Appendix 6A. Table of Contents

Appendix 6A.	Best Management Practices	1
6A-1	Introduction.....	1
6A-2	Best Management Practices.....	1
6A-2.1	Temporary Seeding	1
6A-2.2	Mulching	2
6A-2.3	Blankets.....	4
6A-2.4	Plastic Covering	4
6A-2.5	Polyacrylamide for Soil Erosion Protection.....	5
6A-2.6	Bonded Fiber Matrix & Mechanically Bonded Fiber Matrix	7
6A-2.7	Preserving Natural Vegetation	7
6A-2.8	Sodding	8
6A-2.9	Topsoiling	8
6A-2.10	Conveyance Channel Stabilization	9
6A-2.11	Fencing.....	12
6A-2.12	Stabilized Construction Entrance.....	12
6A-2.13	Tire Wash.....	13
6A-2.14	Construction Road Stabilization	13
6A-2.15	Dust Control	15
6A-2.16	Surface Roughening.....	16
6A-2.17	Pipe Slope Drains.....	17
6A-2.18	Level Spreader	19
6A-2.19	Interceptor Dike and Swale.....	19
6A-2.20	Stormwater Infiltration.....	21
6A-2.21	Check Dams	23
6A-2.22	Triangular Silt Dike (Geotextile-Encased Check Dam).....	24
6A-2.23	Outlet Protection	25
6A-2.24	Vegetated Strip.....	25
6A-2.25	Wattles.....	26
6A-2.26	Compost Sock	27
6A-2.27	Silt Fence.....	27
6A-2.28	Straw Bale Barrier.....	28
6A-2.29	Filter Berm	28
6A-2.30	Storm Drain Inlet Protection	29
6A-2.31	Sediment Trap	30
6A-2.32	Temporary Sediment Pond.....	31
6A-2.33	Concrete Handling	37
6A-2.34	High pH Neutralization	37
6A-2.35	Construction Stormwater Chemical Treatment.....	39
6A-2.36	Construction Stormwater Filtration.....	40

List of Tables

Table 6A-1	Mulch standards and guidelines.....	3
Table 6A-2.	Flexible versus rigid lined conveyances.....	11
Table 6A-3.	Maximum permissible shear stresses for flexible liners.	11
Table 6A-4.	Design criteria.	21
Table 6A-5.	Vegetated filter strips.	26

List of Figures

Figure 6A-1	Temporary sediment pond details	36
-------------	---------------------------------------	----

Appendix 6A.

Best Management Practices

6A-1 Introduction

Read Chapter 6 before applying best management practices (BMPs) to projects.

The following descriptions are provided to aid in the selection of appropriate BMPs for temporary erosion and sediment control (TESC) plans. *Standard Specifications for Road, Bridge, and Municipal Construction (Standard Specifications)* exist for most, but not all, BMPs. The *Standard Specifications* associated with each BMP are referenced in this section; *Standard Plans for Road Bridge, and Municipal Construction (Standard Plans)* are referenced when applicable.

General Special Provisions (GSP) and Special Provisions must be used to ensure the other BMPs are effectively employed. Prior to writing a Special Provision, check the statewide library for existing GSPs and Special Provisions that can be used to satisfy project needs (www.wsdot.wa.gov/eesc/CAE/pse/PLANTBCN.HTM). Regional GSP libraries may also provide useful provisions. Contact region environmental staff or the Statewide Erosion Control Coordinator for assistance in identifying resources when preparing Special Provisions. The Washington State Department of Ecology's (Ecology's) stormwater management manuals for western Washington (SMMWW) and eastern Washington (SMMEW) are especially useful, as they contain thorough sets of BMP specifications (www.ecy.wa.gov/programs/wq/stormwater/index.html).

6A-2 Best Management Practices

6A-2.1 Temporary Seeding

WSDOT Standard Specification
8-01.3(2) – Seeding, Fertilizing, and Mulching

1. Definition

The establishment of a vegetative cover on disturbed areas by seeding with plants. Temporary seeding is used in areas where permanent cover is not necessary or appropriate (such as stockpiles or over-wintering of incomplete grades). Permanent seeding is intended to restore and provide perennial vegetative cover to disturbed areas.

2. Purpose

By protecting bare soil from raindrop impact and binding the soil with its roots, a well-established vegetative cover is one of the most effective methods of reducing erosion.

3. Additional Information/Guidance

The application of agricultural chemicals to promote grass establishment must be conducted in a manner and at application rates that will not result in loss of chemicals to stormwater runoff. Manufacturers' recommendations for application rates and procedures must be followed.

To determine the optimal seed/fertilizer mixes and application specifications for a project, contact the Headquarters (HQ) Roadside and Site Development Section. Additional information can be found in the *Roadside Manual*, Chapter 800 – Vegetation ~ Seed, Fertilizer, and Mulch.

6A-2.2 Mulching

WSDOT Standard Specification

8-01.3(2)D – Mulching

1. Definition

The application of organic material to protect bare soil from raindrop and sheet erosion and enhance seed germination.

2. Purpose

Mulch provides immediate temporary protection from erosion. Mulch also enhances plant establishment by conserving moisture; holding fertilizer, seed, and topsoil in place; and moderating soil temperatures. There are numerous mulches that can be used, such as straw, wood chips (hog-fuel), wood fibers, and compost.

3. Additional Information

Table 6A-1 provides information on types of mulch material, suggested application rate, and other additional information.

Table 6A-1. Mulch standards and guidelines.

Mulch Standards and Guidelines		
Mulch Material	Application Rates	Remarks
Straw	2"-3" thick	Cost-effective protection when applied with adequate thickness. Hand application generally requires greater thickness than blown straw. The thickness of straw may be reduced by half when used in conjunction with seeding. Hand-spread straw is less likely to be displaced by wind or runoff, because of its weight and length. Blown straw is smaller and may be more susceptible to wind and rainfall/runoff action. Erosion blankets/netting or organic and inorganic tackifiers are available to prevent displacement of mulch by wind and rain. (Refer to the WSDOT <i>Standard Specifications</i> for application information.) Straw, however, has some deficiencies that should be considered when selecting mulch materials. It often introduces and/or encourages the propagation of weed species and it has no significant long-term benefits. It should also not be used within the ordinary high-water elevation of surface waters (due to flotation).
Wood Fiber Mulch	Approx. 1,500–2,000 lbs per acre	Shall be applied with hydromulcher. Shall not be used without seed and tackifier unless the application rate is at least doubled. Fibers longer than about $\frac{3}{4}$ –1 inch clog hydromulch equipment. Fibers should be kept to less than $\frac{3}{4}$ inch.
Bonded Fiber Matrix	Approx. 3,000–4,000 lbs per acre: per the manufacturer's recommendation	Shall be applied with a hydromulcher. Shall contain 10% stabilizer or tackifier. May be used as temporary erosion control mulch prior to the seeding window. Requires a 24–48 hour curing time before rain. Under normal circumstances will last 6–12 months. Can be combined with seed and fertilizer during the seeding window.
Mechanically Bonded Fiber Matrix	Approx. 3,000–4,000 lbs per acre: per the manufacturer's recommendation	Shall be applied with a hydromulcher. Shall contain 10% stabilizer or tackifier. Physically bonds with top layer of soil. Does not require a curing time before rains. Soil must be completely covered. Under normal circumstances will last over 12 months. Can be combined with seed and fertilizer during the seeding window.
Compost	2" minimum thickness	Compost material used for erosion control must meet WSDOT Standard Specification 9-14.4(8) for Coarse Compost. Excellent mulch for protecting final grades until landscaping because it can be directly seeded or tilled into soil as an amendment.
Chipped Site Vegetation	2" minimum thickness	This is a cost-effective way to dispose of debris from clearing and grubbing. If seeding is expected shortly after mulch, the decomposition of the chipped vegetation can create a nitrogen deficiency in the soil, making it difficult for plants to grow well. Generally, it should not be used on slopes above approx. 10% because of its tendency to be transported by runoff. It is not recommended within 200 feet of surface waters. Wood chip mulch is also a suitable material for stabilizing entrances and haul roads that are not heavily used by construction vehicles.
Wood-Based Mulch	2" thick; approx. 100 tons per acre (approx. 800 lbs per cubic yard)	This material is often called "hog or hogged fuel." Hog fuel is also a suitable material for stabilizing entrances and haul roads that are not heavily used by construction vehicles. The use of mulch ultimately improves the organic matter in the soil. Special caution is advised regarding the source and composition of wood-based mulches. Its preparation typically does not provide any weed seed control, so evidence of residual vegetation in its composition or known inclusion of weed plants or seeds should be monitored and prevented (or minimized).

6A-2.3 Blankets

WSDOT Standard Specifications

8-01.3(3) – Placing Erosion Control Blanket

9-14.5(2) – Erosion Control Blanket

WSDOT Standard Plans

I-60.10-00 – Erosion Control Blanket Placement on Slope

I-60.20-00 – Erosion Control Blanket Placement in Channel

1. Definition

A blanket made of natural plant material or synthetic fibers that is rolled out and fastened to the soil surface to protect soil from raindrop and sheet erosion.

2. Purpose

Erosion control blankets protect soil from raindrop and sheet erosion until permanent vegetation is established. Organic blankets are made of jute, straw, wood shavings, coconut fiber (coir), or various combinations of each. Product longevity ranges from 6 months to 5 years, depending on the composition of the blanket and environmental conditions. Synthetic blankets often contain materials that resist ultraviolet light and last more than 5 years. While most are suitable for slopes, others can be used in ditches with considerable flow volumes/velocities.

3. Additional Information/Guidance

- Slopes must be prepared (smooth) prior to blanket installation so that the blanket makes contact with the entire soil surface when secured.
- Blankets must be keyed in at the top of the slope to prevent water from going under, and upslope sections must be placed over downslope sections like shingles on a roof.

6A-2.4 Plastic Covering

WSDOT Standard Specifications

8-01.3(5) – Placing Plastic Covering

9-14.5(3) – Clear Plastic Covering

1. Definition

The covering with plastic sheeting of bare areas that need immediate protection from erosion.

2. Purpose

The primary uses for plastic are:

- Coverage of slopes and stockpiles.
- Temporary coverage of active work areas.
- Short-term coverage where mulch or blankets are not an option.
- Protection of seed from cold weather to encourage early growth of vegetation.

3. Additional Information/Guidance

- Plastic provides 100% protection of the soil; however, it collects 100% of the rain and transfers the erosion potential elsewhere. Therefore, energy dissipation downslope of the plastic, as well as conveyance of runoff, should be anticipated and addressed appropriately with other BMPs.
- As with erosion control blankets, plastic must be keyed in at the top of the slope to prevent water from going under the plastic, and upslope sheets must be placed over downslope sheets like shingles on a roof.
- There is a misconception that plastic is cheaper and easier to use than erosion blankets. However, the average cost per square yard of installed plastic is often greater than the cost of many erosion control blankets, especially when maintenance, removal, and disposal costs are added.

6A-2.5 Polyacrylamide for Soil Erosion Protection

WSDOT Standard Specification

8-01.3(2)E – Tacking Agent and Soil Binders/Soil Binding Using Polyacrylamide

1. Definition

Polyacrylamide (PAM) is a long-chain polymer developed to clarify drinking water. It can be used in erosion and sediment control applications because of its ability to stabilize soils and remove fine suspended sediments from stormwater runoff at highway construction sites. PAM also increases infiltration rates in soils by preventing surface sealing.

2. Purpose

Applying PAM to bare soil in advance of a rain event reduces erosion and controls sediment transport. First, PAM binds soil particles together and reduces the effects of raindrop and sheet erosion. As a result, stormwater infiltration is increased because the soil pore volume is not clogged with fine

sediments. Second, stormwater pond performance is enhanced because sediment that reaches the pond contains PAM. The polymer binds the smaller particles together, making longer, heavier particles that settle out of suspension faster than in the absence of PAM. Consequently, PAM can make conventional BMPs much more effective.

3. Additional Information/Guidance

- PAM products must meet ANSI/NSF Standard 60 for drinking water treatment and be anionic and linear (non-cross-linked).
- PAM must not be applied directly to water or allowed to enter a water body. **All soil treated with PAM must drain to a sediment pond or trap prior to discharge.**
- In areas that drain to a sediment pond, PAM may be applied to bare soil under the following conditions:
 - During rough-grading operations
 - In staging areas
 - On balanced cut-and-fill earthwork
 - On haul roads prior to placement of crushed rock surfacing
 - On compacted soil road base
 - On stockpiles
 - After final grade and before paving or final seeding and planting
 - In pit sites
- PAM should be used in combination with mulch per the WSDOT Standard Specifications. However, PAM can be used in areas of active construction to protect the soil from erosion over a time period consistent with the soil coverage time limits identified in Standard Specification 8-01.3(1) (PAM can be used to cover soil over the weekend to resume work on Monday).
- All areas not being actively worked shall be covered and protected from rainfall. PAM shall not be the only cover BMP used.
- For small areas that need coverage, PAM can be applied at the dry application rate using a hand-held “organ grinder” seed spreader.
- Depending on site conditions, PAM remains in the soil 3 to 6 months from the date of application. Extreme weather and heavy traffic (if used on haul roads) shorten the lifespan. These conditions require more frequent application.
- Refer to Ecology’s SMMWW, Volume II, for more information on PAM.

6A-2.6 Bonded Fiber Matrix & Mechanically Bonded Fiber Matrix

WSDOT Standard Specification

8-01.3(2)E – Tacking Agent and Soil Binders

1. Definition

Bonded Fiber Matrix (BFM): A combination of wood fiber and organic or synthetic tackifier that can be mixed with seed and applied hydraulically. Requires at least a 48-hour cure time and should not be used on saturated soils with groundwater seeps.

Mechanically Bonded Fiber Matrix (MBFM): A combination of wood fiber, organic or synthetic tackifiers, and crimped interlocking poly fibers that can be mixed with seed and applied in advance of or during precipitation and on saturated soil.

2. Purpose

Soil stabilization BMPs that form a permeable crust over disturbed soils to protect from raindrop impacts. Both products provide better protection than wood cellulose fiber alone. They can be applied with seed or as a stand-alone BMP.

3. Additional Information

WSDOT's Qualified Products List (QPL) contains approved vendors of BFM and MBFM products.

6A-2.7 Preserving Natural Vegetation

WSDOT Standard Specification

1-07.16(2) – Vegetation Protection and Restoration

1. Definition

Minimizing exposed soils by clearing only where construction will occur or preserving an undisturbed strip of natural vegetation or preserving an established suitable planting between sensitive areas and land-disturbing activities.

2. Purpose

Vegetation provides the following benefits:

- Rainfall impact (energy) absorption
- Reduction of runoff volumes and velocities
- Sediment trapping
- Root stabilization of soil

Preserving natural vegetation reduces the need to spend money on BMPs that try to mimic these natural benefits. Vegetation surrounding sensitive areas (buffer zones) provides critical habitat and assists in controlling erosion, especially on unstable steep slopes.

3. Additional Information/Guidance

Buffer zones must be identified and protected with fencing around wetlands, streams, and other sensitive areas. These areas should not be used as sediment filters. Check with the local jurisdiction or WSDOT environmental permitting staff.

6A-2.8 Sodding

WSDOT Standard Specification

9-14.6(8) – Sod

1. Definition

Stabilizing fine-graded disturbed areas by establishing permanent grass stands with sod.

2. Purpose

To establish permanent turf for immediate erosion protection or to stabilize drainageways where concentrated overland flow will occur.

3. Additional Information

- Sod may be more expensive than other permanent-cover BMPs, but because the grass is already established, instant protection is provided.
- In swales, placing sod strips perpendicular to the flow of water increases the ability to resist shear stress.
- Staggering sod strips produces a more stable soil cover.
- For maintenance information, refer to WSDOT Standard Specification 8-01.3 (15), Maintenance.

6A-2.9 Topsoiling

WSDOT Standard Specifications

8-02.3(4) – Topsoil

9-14.1 – Soil

1. Definition

Preserving or importing topsoil to promote vegetation establishment in nutrient-poor soils.

2. Purpose

To provide a suitable growth medium for final site stabilization.

6A-2.10 Conveyance Channel Stabilization

WSDOT Standard Specification

For flexible liners, the information below can be used to select appropriate materials. Materials and installation Standard Specifications already exist for these liner types.

If it is determined that a rigid liner is necessary, contact the WSDOT HQ Design Office, Hydraulics Branch. No WSDOT Standard Specification exists for solid liners; therefore, a Special Provision must be written. For instructions on preparing Special Provisions, see the Introduction (6A-1).

1. Definition

Temporary conveyance channels must be designed, constructed, and stabilized to prevent erosion. Materials used to stabilize channels against erosion are categorized as flexible and rigid. Flexible channel liners include vegetation, blankets, gravel, and small- to medium-sized riprap. Rigid materials used for conveyance systems include PVC/concrete/metal pipe, asphalt, and large rock.

2. Purpose

To stabilize the conveyance feature sufficiently to prevent erosion up to the design storm flow.

3. Additional Information/Guidance

Channels should be sized to convey expected flows. Use the design criteria contained in Section 4-3.3 for western Washington or Section 4-4.3 for eastern Washington.

The following general guidance comes from the *Hydraulic Engineering Circular No. 15 – Design of Roadside Channels with Flexible Linings*, Federal Highways Department publication No. FHWA-IP-87-7.

The following principles must be considered when designing stable channels:

- Bare soil has very little resistance to erosion when subjected to concentrated flows. Channels must be protected to withstand expected erosive forces.

- Flow velocities should be limited, if necessary, to prevent damage to channel liners.
- Flexible liners are not as strong as rigid liners, but are able to conform to changes in channel shape while maintaining the overall lining integrity. As a general guideline, only rigid liners should be used in channels with shear stresses exceeding 8 lb/ft² or on slopes exceeding 10%, unless using properly sized riprap. Table 6A-2 summarizes the advantages and disadvantages of the two liner types.

The potential for erosion is based on the shear stress of flow, which is the force required to pull or peel (erode) material off the bottom or sides of a ditch. Shear stress can be calculated using the following formula:

$$\text{Shear Stress} = WHG \quad \text{where:}$$

$$W = \text{Weight of water (62.4 lb/ft}^3\text{)}$$

$$H = \text{Height of water in feet}$$

$$G = \text{Channel gradient in ft/ft}$$

Note: Channel gradient and water height in this formula assume an unobstructed flow of water in the ditch.

- Using shear stress to determine effective liner types:

Table 6A-3 indicates the maximum shear stresses that several types of flexible liner materials can withstand. As a general guideline when rock lining is used, multiply the expected maximum shear stress by 3 to apply a 30% safety factor, to obtain the mean diameter of rock or riprap needed to stabilize the ditch. Manufacturers provide the shear strength ratings for erosion control blankets.

Selection of liner material should be based on the maximum shear stress that products or specified rock sizes can withstand.

- Sample calculation and product selection process:

What flexible liner materials are adequate to stabilize a ditch with a 3% slope and an expected flow depth of 1.5 feet?

$$\text{Shear stress} = (62.4 \text{ lb/ft}^3)(1.5 \text{ ft})(.03) = 2.81 \text{ lb/ft}^2$$

If rock is used, stone size should be a minimum mean stone size of at least 8.4 inches, because $(2.81)(3.0 \text{ conversion factor}) = 8.4$.

Numerous erosion control blankets made of coir and synthetic turf reinforcement products could be substituted for rock with potentially significant cost savings. A well-established healthy stand of grass could also withstand the expected shear stresses in the ditch and help purify the runoff.

Consider coupling other BMPs with the channel lining to ensure channel stability. Check dams can greatly reduce the velocity of flowing water, thereby reducing shear stress. Check dams can prevent erosion until the permanent grass liner is established. Temporary slope drains provide rigid lined conveyances until the permanent rigid or flexible lined channels are completed.

Table 6A-2. Flexible versus rigid lined conveyances.

Flexible	Rigid
<p><i>Advantages</i></p> <ul style="list-style-type: none"> ▪ Inexpensive to install and maintain (grass-lined ditches are self-healing) ▪ Provide runoff treatment ▪ Allow some infiltration ▪ Cause less increase in peak flows 	<p><i>Advantages</i></p> <ul style="list-style-type: none"> ▪ Maximize conveyance capacity using limited space ▪ Fully effective immediately (no need to wait for grass to grow) ▪ Can be designed to withstand any level of shear stress
<p><i>Disadvantages</i></p> <ul style="list-style-type: none"> ▪ Excessive flows can cause erosion ▪ Vegetation requires time to become established ▪ Require more space ▪ Not to be used in channels where shear stress exceeds 8 lb/ft² or slopes exceed 10% (except riprap) 	<p><i>Disadvantages</i></p> <ul style="list-style-type: none"> ▪ Expensive to build, maintain, and repair ▪ Increased peak discharge rates more likely to cause downstream erosion ▪ Minimal, if any, infiltration ▪ No runoff treatment

Table 6A-3. Maximum permissible shear stresses for flexible liners.

Liner Category	Liner Type	Permissible Shear Stress (lbs/ft ²)
Bare soil – No liner	Noncohesive soil	0.01-0.04
	Cohesive soil	up to 0.1 (noncompacted)/ up to 0.8 (compacted)
Erosion control blankets (temporary/permanent)*	Jute	0.45-1.0
	Curlex wood or straw	1.0-2.5
	Coir	2.0-4.0
	Organic, synthetic, or mix	10.0-12.0
Vegetative**	Uncut stand	2.1-3.7
	Cut grass	0.6-1.0
Gravel/riprap	1-inch	0.33
	2-inch	0.67
	6-inch	2.0
	12-inch	4.0

* Permissible shear stresses based on products chosen at random to give a general idea of blanket strengths by material type. This table does not reflect the full range of permissible shear stresses for each product type.

** Varies with type and density of grass stand.

6A-2.11 Fencing

WSDOT Standard Specifications

1-07.16(2) – Vegetation Protection and Restoration

1-07.16(3) – Fences, Mailboxes, Incidentals

WSDOT Standard Plan

I-10.10-00 – High Visibility Construction Fencing

A Special Provision must be prepared if a particular fencing design or material is necessary. For instructions on preparing Special Provisions, see the Introduction (6A-1). *Project Delivery Memo #04-04*, dated August 11, 2004, addresses high-visibility construction fencing. Regions should adapt the Special Provision to best fit their methods of presentation while retaining the intent.

1. Definition

Installing a physical barrier to define a project boundary or protect a sensitive feature.

2. Purpose

Fencing restricts clearing to approved limits, prevents disturbance of sensitive areas, and limits construction traffic to designated roads and entrances.

3. Additional Information/Guidance

- Suitable fencing materials include plastic safety fence, metal fence, and silt fence. Plastic safety fence or high-visibility fence should be installed in advance of clearing and grubbing to delineate sensitive areas. Silt fence is appropriate in areas where there is concern about turbid runoff leaving the site. However, safety fence and other material should always be considered in place of silt fence where there is no concern about runoff.
- Fencing is used to meet Elements 1 (high-visibility fencing) and 4 (silt fencing) of a TESC plan (see Chapter 6).
- Maintenance – Refer to WSDOT Standard Specification 8-01.3(15), Maintenance.

6A-2.12 Stabilized Construction Entrance

WSDOT Standard Specification

8-01.3(7) – Stabilized Construction Entrance

WSDOT Standard Plan

I-80.10-00 – Miscellaneous Erosion Control Details

1. Definition

A temporary stone-stabilized pad located at points of vehicular ingress and egress on a construction site.

2. Purpose

To reduce the amount of mud, dirt, rocks, and so forth, transported onto public roads by motor vehicles or runoff.

3. Additional Information

- A stabilized rock pad can be implemented for all staging and employee parking areas for the project.
- For maintenance, refer to WSDOT Standard Specification 8-01.3(15), Maintenance.

6A-2.13 Tire Wash

WSDOT Standard Specification

8-01.3(7) – Stabilized Construction Entrance

1. Definition

A system using sump and spray equipment to remove sediment from vehicles during site egress.

2. Purpose

A tire wash is used when a stabilized construction entrance does not prevent sediment from being tracked onto off-site pavement.

3. Additional Information/Guidance

- Effective function requires participation by and communication with vehicle drivers.
- Wash-water shall be discharged to a separate on-site treatment system, such as closed-loop recirculation or land application, or discharged to a sanitary sewer, if allowed by individual permit.
- Local jurisdictions may require a tire wash as a permit condition.

6A-2.14 Construction Road Stabilization

WSDOT Standard Specification

Standard Specifications exist for road stabilization materials, but a Special Provision must be

written describing when, where, and how much material is to be used. For instructions on preparing Special Provisions, see the Introduction (6A-1).

1. Definition

The temporary stabilization of access roads and other on-site vehicle transportation routes immediately after grading.

2. Purpose

To reduce erosion of temporary roadbeds by construction traffic during wet and dry weather. Construction road stabilization eliminates the need for regrading of permanent road beds between the time of initial grading and final stabilization and reduces dust emissions.

3. Additional Information/Guidance

- If the area will not be used for permanent roads, parking areas, or structures, a 6-inch depth of hog fuel may also be used (but this is likely to require more maintenance). Whenever possible, construction roads and parking areas are placed on a firm, compacted subgrade.
- On areas that will receive asphalt as part of the project, install the first lift as soon as possible.
- A 6-inch depth of 2- to 4-inch crushed rock, gravel base, or crushed surfacing base course can be applied immediately after grading or utility installation. A 4-inch course of asphalt treated base (ATB) may also be used, or the road/parking area may be paved. It may also be possible to use cement or calcium chloride for soil stabilization. If cement or cement kiln dust is used for roadbase stabilization, pH monitoring and other BMPs are necessary to evaluate and minimize the impact on stormwater.
- Roadways must be carefully graded to drain effectively. Drainage ditches are required on each side of the roadway in the case of a crowned section or on one side in the case of a super-elevated section. Drainage ditches should be directed to a sediment control BMP.
- Rather than relying on ditches, it may also be possible to grade the road so that runoff sheet-flows into a heavily vegetated area with well-developed topsoil. If the vegetated area has at least 50 feet of vegetation, it is generally preferable to use the vegetation, rather than a sediment pond or trap, to treat runoff.
- Storm drain inlets receiving runoff from temporary construction roadways must be protected to prevent sediment-laden water from entering the storm drain system.
- Inspect stabilized areas regularly, especially after large storm events.

- Crushed rock, gravel base, hog fuel, and so forth, should be added as required to maintain a stable driving surface and to stabilize any areas that have eroded.

6A-2.15 Dust Control

WSDOT Standard Specification

No WSDOT Standard Specification exists, so a Special Provision must be written. For instructions on preparing Special Provisions, see the Introduction (6A-1).

1. Definition

Reducing the movement of dust during land-disturbing, demolition, and construction activities.

2. Purpose

To prevent movement of dust where on-site and off-site impacts to roadways, drainage ways, or surface waters are likely.

3. Additional Information/Guidance

- Vegetate or mulch areas that will not receive vehicle traffic. In areas where planting, mulching, or paving is impracticable, apply gravel or landscaping rock.
- Limit dust generation by clearing only those areas where immediate activity will take place.
- Construct natural or artificial windbreaks or windscreens.
- Spray the site with water until the surface is wet. Repeat as needed. To prevent mud being carried onto adjacent streets, install a Stabilized Construction Entrance and/or a Tire Wash as necessary.
- Spray exposed soil areas with a dust palliative, following the manufacturer's instructions and cautions regarding handling and application. Used oil is prohibited as a dust suppressant. Local governments may approve other dust palliatives (such as calcium chloride or PAM).
- Techniques that can be used for unpaved roads and lots include:
 - Lower speed limits.
 - Upgrade the road surface strength by improving particle size, shape, and mineral types that make up the surface and base materials.

- Add surface gravel to reduce the source of dust emission. Limit the amount of fine particles (those passing a #200 screen) to 10% to 20%.
- Use geotextile fabrics to increase the strength of new roads or roads undergoing reconstruction.
- Encourage the use of alternative, paved routes, if available.
- Restrict use by tracked vehicles and heavy trucks to prevent damage to the road surface and base.
- Apply chemical dust suppressants using the admix method: blending the product with the top few inches of surface material. Suppressants may also be applied as surface treatments.
- Pave permanent roads and other high-traffic areas.
- Use vacuum street sweepers.
- Remove mud and other dirt promptly so it does not dry and turn into dust.
- Limit dust-causing work on windy days.
- Contact the local air pollution control authority for guidance and training on other dust control measures. Compliance with the local air pollution control authority constitutes compliance with this BMP.

6A-2.16 Surface Roughening

WSDOT Standard Specification

8-01.3(2)A – Preparation for Application

1. Definition

Creating longitudinal depressions perpendicular to the natural flow of runoff by using a cleated roller, crawler tractor, or similar equipment.

2. Purpose

To aid in the establishment of vegetative cover by reducing runoff velocity, increasing infiltration, and providing for sediment trapping.

3. Additional Information/Guidance

There are different methods for achieving a roughened soil surface on a slope; the selection of an appropriate method depends on the type of slope.

Roughening methods include stairstep grading, grooving, contour furrows, and track walking. Factors to be considered in choosing a method are slope

steepness, mowing requirements, and whether the slope is formed by cutting or filling.

- Disturbed areas that will not require mowing may be stairstep graded, grooved, or left rough after filling.
- Stairstep grading is particularly appropriate in soils containing large amounts of soft rock. Each step catches material that sloughs from above and provides a level site where vegetation can become established. Stairs should be wide enough to work with standard earth-moving equipment. Stairsteps must be on contour or gullies will form on the slope.
- Areas that will be mowed (these areas should have slopes less steep than 3H:1V) may have small furrows left by disking, harrowing, raking, or seed-planting machinery operated on the contour.
- Graded areas with slopes greater than 3H:1V, but less than 2H:1V, should be roughened before seeding. This can be accomplished in a variety of ways, including track walking or driving a crawler tractor up and down the slope, leaving a pattern of cleat imprints parallel to slope contours.

6A-2.17 Pipe Slope Drains

WSDOT Standard Specification

8-01.3(14) – Temporary Pipe Slope Drain

1. Definition

A pipe extending from the top to the bottom of a slope and discharging into a stabilized water course, a sediment-trapping device, or a stabilized outfall.

2. Purpose

To carry concentrated runoff down slopes without causing the formation of rills and gullies and to minimize saturation of slide-prone soils.

3. Additional Information/Guidance

- If flow is exclusively surface water, use the design criteria contained in Section 4-3.3 for western Washington or Section 4-4.3 for eastern Washington.
- If flow is from seeps or groundwater, use best professional judgment in consultation with the Region Materials Engineer (RME) when sizing slope drains.

- Pipe slope drains can be used when a temporary or permanent stormwater conveyance is needed to move the water down a slope to prevent erosion.
- Pipe slope drains can be used at bridge ends to collect runoff and pipe it to the base of the fill slopes along bridge approaches. These can be designed into a project and included as bid items.
- Another use on road projects is to collect runoff from pavement and pipe it away from side slopes. This is useful because there is generally a time lag between installation of the first lift of asphalt and installation of curbs, gutters, and permanent drainage.
- Water can be collected and channeled to pipe slope drain inlets with sand bags, triangular silt dikes, berms, or other material.
- Use temporary drains on new slopes.
- Compact the soil around and under the pipe and entrance section to prevent undercutting.
- Securely connect prefabricated flared inlet sections to the slope drain pipe.
- Securely fasten multiple slope drain sections together, or use gasketed watertight fittings.
- If 90° bends cannot be avoided in the drain pipe, install thrust blocks constructed from sandbags; straw bales staked in place; “t” posts and wire; or ecology blocks to anchor the bends. For pipe slope drains that are to remain as permanent features, the thrust block materials must be capable of lasting for the expected life of the pipe.
- Secure pipe along its full length to prevent movement. This can be done with steel “t” posts and wire. Posts are installed on each side of the pipe and the pipe is wired to them. This should be done approximately every 10–20 feet of pipe length, depending on the size of the pipe and quantity of water to be diverted.
- Pipe slope drains can be used to convey water collected by interceptor dikes. Ensure the height of the dike is at least 1 foot higher at all points than the top of the inlet pipe.
- The area below the outlet must be stabilized with an energy-dissipating material (such as riprap).
- If the pipe slope drain is conveying sediment-laden water, direct all flows into a sediment-trapping facility.

6A-2.18 Level Spreader

WSDOT Standard Specification

No WSDOT Standard Specification exists, so a Special Provision must be written. For instructions on preparing Special Provisions, see the Introduction (6A-1).

1. Definition

A slightly elevated structure made of wood, sandbags, pipe, compost, gravel, or compacted earth that spans an area and converts concentrated runoff into sheet flow.

2. Purpose

To reduce shear stress by converting concentrated runoff to sheet flow, resulting in less erosion.

3. Additional Information/Guidance

- Use when a concentrated flow of water needs to be dispersed over a large area with existing stable vegetation.
- Use only where the slopes are gentle, the water volume is relatively low, and the soil will absorb most of the low-flow events.
- Use above areas that are stabilized by vegetation.
- If the level spreader has any low points, flow will concentrate, creating channels and possibly causing erosion.
- Design the level spreader so that runoff does not reconcentrate after release unless intercepted by another downstream measure.
- Level spreaders consisting of gravel or organic material should have a minimal amount of fine particles that could negatively influence turbidity.
- The spreader should span the full width of the channel. Use multiple spreaders for higher flows.
- The depth of the spreader, as measured from the lip, should be uniform across the entire width.
- Level spreaders should be set back from the property line unless there is an easement for flow.

6A-2.19 Interceptor Dike and Swale

WSDOT Standard Specification

No WSDOT Standard Specification exists, so a Special Provision must be written.

For instructions on preparing Special Provisions, see the Introduction (6A-1). The design criteria shown in Table 6A-4 apply.

1. Definition

A ridge of compacted soil with a parallel swale placed on a slope. These structures may or may not be vegetated. They differ from water bars in that they are of greater scale and complexity.

2. Purpose

To intercept runoff and/or groundwater from drainage areas on slopes and direct it to a stabilized outlet.

3. Additional Information/Guidance

Use the dike and swale to intercept the runoff from unprotected areas and direct it to areas where erosion can be controlled. This can prevent runoff from entering the work area or sediment-laden runoff from leaving the construction site.

- When placed horizontally across a disturbed slope, the dike and swale reduces the amount and velocity of runoff flowing down the slope.
- Stabilization of the dike and swale with temporary or permanent vegetation depends on soil characteristics and gradient. Low-gradient, highly-porous soils may not require a higher level of protection, because much of the water infiltrates the ground, reducing erosion potential.
- Steeper grades require swale protection, check dams, or level spreaders.
- Provide energy dissipation measures at swale outlet.
- Sediment-laden runoff must be released to a sediment-trapping facility.
- Minimize construction traffic over temporary dikes. Use temporary cross culverts for channel crossing.

Table 6A-4. Design criteria.

Interceptor dikes meet the following criteria:	
Top width	2 feet (600 mm) minimum.
Height	18 inches (450 mm) minimum. Measured from upslope toe and at a compaction of 90% ASTM D698 standard proctor.
Side slopes	3H:1V or flatter.
Grade	Topography dependent, except that dike is limited to grades between 0.5 and 1.0%.
Horizontal spacing of interceptor dikes	Slopes <5% = 300 feet (90 m) Slopes 5–10% = 200 feet (60 m) Slopes 10–40% = 100 feet (30 m)
Stabilization	Slopes = <5%. Seed and mulch applied within 5 days of dike construction. Slopes = 5–40%. Dependent on runoff velocities and dike materials. Stabilization, using either sod or riprap, should be done immediately to avoid erosion.
Outlet	The upslope side of the dike must provide positive drainage to the dike outlet. No erosion can occur at the outlet. Provide energy dissipation measures as necessary. Sediment-laden runoff must be released through a sediment-trapping facility.
Other	Minimize construction traffic over temporary dikes.
Interceptor swales meet the following criteria:	
Bottom width	2 feet (600 mm) minimum; the bottom is level.
Depth	1 foot (300 mm) minimum.
Side slope	3H:1V or flatter.
Grade	Maximum 5%, with positive drainage to a suitable outlet (such as a sediment trap).
Stabilization of swale bottom and side slopes	Seed per Standard Specification 8-01.3(2) Temporary seeding, or riprap 12 inches (300 mm) thick, pressed into the bank and extending at least 8 inches (200 mm) vertical from the bottom.
Swale spacing	Slope of disturbed area: <5% = 300 feet (90 m) 5–10% = 200 feet (60 m) 10–40% = 100 feet (30 m)
Outlet	Level spreader or riprap to stabilized outlet/sedimentation pond.

6A-2.20 Stormwater Infiltration

WSDOT Standard Specification
8-01.3(1)D – Dispersion/Infiltration

1. Definition

The process of treating water in engineered infiltration ponds, naturally occurring closed depressions, and vegetated areas with soils or duff that can absorb stormwater.

2. Purpose

To treat turbid stormwater that would otherwise not meet water quality standards if discharged to a surface water body. If a standard BMP is not providing sufficient treatment prior to discharge, additional treatment may include dispersion into WSDOT-owned vegetated strips and grass-lined channels that can be expected to infiltrate runoff or reduce turbidity prior to discharging from a site. Prior written authorization must be obtained from adjacent landowners before water can be dispersed onto adjacent non-WSDOT properties. Dispersion, infiltration, and bioinfiltration areas will be labeled on the TESC plan sheets, and visual inspections must be completed daily to verify that they function as intended. Flow to such areas will be controlled to encourage complete infiltration and avoid discharges whenever possible. If discharges occur, however, runoff will be sampled at the dispersion area discharge point in accordance with permit conditions. Inspection frequency will increase (daily inspections during dispersion operations) whenever there are discharges or whenever weather conditions are likely to limit the capacity or effectiveness of treatment areas. Use of dispersion areas will immediately cease if they stop providing improved treatment compared to direct discharges from traditional BMPs.

Ditched stream channels and other sensitive areas shall never be considered for dispersion, infiltration, or biofiltration activities. Dispersion and infiltration in Critical Aquifer Recharge Areas will not be allowed in areas identified in the Geotechnical Report as having less than 5 feet between the ground surface and the seasonal high groundwater table. Roadside ditches shall only be used when they can reasonably be expected to prevent runoff or fine sediments from reaching receiving streams based on field observations and soils information. (Note: WSDOT maintenance personnel are an excellent resource, with many years of observations about flow under wet weather conditions.) Check dams and other BMPs shall be installed where necessary to enhance the effectiveness of the dispersion and biofiltration BMPs. The BMPs will be maintained and deposited sediment will be removed if necessary to eliminate the possibility of sediment resuspension during future rain events. If present, deposited sediment shall be stabilized or removed at the end of the project.

This method can often be employed to create a zero discharge site, thereby eliminating the possibility of impacting surface waters.

3. Additional Information/Guidance

- Infiltration ponds work best on highly porous soils. Silt and clay deposits reduce infiltration capacity. Upslope erosion/sediment control BMPs, especially sediment traps/basins, are essential to ensure

consistent performance of infiltration facilities, whether used as temporary or permanent water quality/quantity BMPs.

- Infiltration rates are usually higher in undisturbed, vegetated areas.
- Infiltration rates are limited on most sites, so creative methods are often required to meet infiltration needs.
- Infiltration can be maximized by spreading water over the largest possible area, discharging water at a slow and constant rate, and using vegetated areas whenever possible.
- If an area becomes saturated, give it a rest period and try again later.
- Design infiltration areas to empty between storm events.
- Monitor infiltration areas and nearby surface waters. Infiltrating water on slopes may destabilize the slope, causing structural failure.
- Always consult with and get approval from the Project Engineer before dispersing or infiltrating water.

6A-2.21 Check Dams

WSDOT Standard Specifications

8-01.3(6) – Check Dams

8-01.3(6)A – Geotextile-Encased Check Dam

8-01.3(6)B – Rock Check Dam

8-01.3(6)C – Sandbag Check Dam

8-01.3(6)D – Wattle Check Dam

WSDOT Standard Plans

I-50.10-00 – Geotextile-Encased Check Dam Installation

I-50.20-00 – Check Dams

1. Definition

Small dams constructed across a swale or drainage ditch. Suitable materials include quarry spalls, riprap, washed gravel, sandbags, and prefabricated structures.

2. Purpose

To reduce the velocity of concentrated flows, reduce erosion of the swale or ditch, and cause some suspended sediment to settle in ponded areas upstream of check dams.

3. Additional Information/Guidance

- Whatever material is used, the cross section of the dam crest should form a triangle. This prevents undercutting at the downstream toe, as water flows over the face of the dam rather than falling directly onto the ditch bottom.
- The material used to fill sand bags should be selected so that it does not contribute to turbid runoff (for example, use washed rock or pea gravel instead of silty sand).
- Keep the center of the check dam lower than the outer edges at natural ground elevation to prevent flooding of roads, dikes, or other structures.
- Placing rock, geotextile, or erosion control blankets in the conveyance channel reduces or eliminates scouring.

6A-2.22 Triangular Silt Dike (Geotextile-Encased Check Dam)

WSDOT Standard Specifications

8-01.3(6) – Check Dams

8-01.3(6)A – Geotextile-Encased Check Dam

1. Definition

A prefabricated check dam consisting of a urethane foam core encased in geotextile material.

2. Purpose

To reduce the velocity of concentrated flows, reduce erosion of the swale or ditch, and cause some suspended sediment to settle in ponded areas upstream of check dams. A triangular silt dike can be mobilized and placed quickly. If they are taken care of, triangular silt dikes can be reused.

3. Additional Information

- The flexibility of the materials in triangular silt dikes allows them to conform to all channel configurations.
- Triangular silt dikes can be fastened to soil with staples or rock and to pavement with adhesives.
- Triangular silt dikes have been used to build temporary sediment ponds, diversion ditches, concrete wash-out facilities, curbing, water bars, level spreaders, and berms.

6A-2.23 Outlet Protection

WSDOT Standard Specification

No WSDOT Standard Specification exists, so a Special Provision must be written. For instructions on preparing Special Provisions, see the Introduction (6A-1). The Region Hydraulics Office should be consulted whenever shear stresses require solid liners.

1. Definition

A protective barrier of rock, erosion control blankets, vegetation, or sod constructed at a conveyance outlet.

2. Purpose

To prevent erosion and scour at drainage conveyance outlets and minimize the potential for downstream erosion by reducing the velocity of concentrated stormwater flows.

3. Additional Information/Guidance

- Common locations for outlet protection include discharge points for ponds, pipes, ditches, or other conveyances.
- Size the scale of the outlet protection based on expected flow volumes and velocities.
- Refer to the *Hydraulics Manual* for guidance in choosing appropriate-sized rock outlet protection or alternative materials.

6A-2.24 Vegetated Strip

WSDOT Standard Specification

No WSDOT Standard Specification exists, so a Special Provision must be written. For instructions on preparing Special Provisions, see the Introduction (6A-1).

1. Definition

A strip of dense vegetation adjacent to a land-disturbing activity.

2. Purpose

To reduce the transport of sediment from a construction site by providing a physical barrier that reduces runoff velocities.

3. Additional Information/Guidance

Vegetated strips may be used downslope of all disturbed areas. The strips are not intended to treat concentrated flows, nor are they intended to treat substantial amounts of overland flow. Any concentrated flows must be conveyed through the drainage system to a sediment pond or a comparable

BMP. The only circumstance in which overland sheet flow can be treated solely by a strip, rather than by a sediment pond or comparable BMP, is when the criteria shown in Table 6A-5 are met.

Ideally, vegetated strips consist of undisturbed native growth with a well-developed soil that allows for infiltration of runoff.

Table 6A-5. Vegetated strips.

Average Slope	Slope Percent	Flowpath Length
1.5H:1V or less	67% or less	100 feet
2H:1V or less	50% or less	115 feet
4H:1V or less	25% or less	150 feet
6H:1V or less	16.7% or less	200 feet
10H:1V or less	10% or less	250 feet

6A-2.25 Wattles

WSDOT Standard Specification
8-01.3(10) – Wattles

WSDOT Standard Plan
I-30.30-00 – Wattle Installation On Slope

1. Definition

Temporary erosion and sediment control barriers consisting of any plant material that is wrapped in biodegradable fiber, tubular plastic, or similar encasing material. Wattles are greater than 5 inches in diameter and 25 to 30 feet in length.

2. Purpose

The two main purposes of wattles are to reduce slope length and to trap sediment. Cutting a slope length in half reduces erosion potential by a factor of four. Wattles also trap sediment, whether used on a slope or as a perimeter control device.

3. Additional Information

Wattles can also be used as temporary curbs for conveying water to catch basins, check dams, and pipe slope drain inlets.

6A-2.26 Compost Sock

WSDOT Standard Specification

8-01.3(12) – Compost Sock

WSDOT Standard Plan

I-30.40-00 – Compost Sock

1. Definition

Temporary erosion and sediment control barriers consisting of a bio- or photodegradable fabric tube filled with compost.

2. Purpose

The main purpose of a compost sock is as a perimeter control device to trap sediment and slow down runoff. Compost socks can be used in place of silt fence in some areas where low stormwater flows are expected. They are especially useful near sensitive areas where soil disturbance should be kept to a minimum.

6A-2.27 Silt Fence

WSDOT Standard Specification

8-01.3(9)A – Silt Fence

WSDOT Standard Plans

I-30.10-00 – Silt Fence

I-30.20-00 – Temporary Silt Fence for Inlet Protection In Unpaved Areas

1. Definition

A temporary sediment barrier consisting of a geotextile fabric stretched across and attached to supporting posts, which are entrenched. Adding rigid wire fence backing can strengthen silt fence.

2. Purpose

To reduce the transport of sediment from a construction site by providing a temporary barrier to sediment and reducing the runoff velocities of sheet flow.

3. Additional Information/Guidance

- Place fence below disturbed areas subject to sheet and rill erosion.
- Place fence on contour to maximize sediment-trapping performance.

6A-2.28 Straw Bale Barrier

WSDOT Standard Specification

8-01.3(9)C – Straw Bale Barrier

WSDOT Standard Plan

I-30.50-00 – Straw Bale Barrier

1. Definition

A temporary sediment barrier consisting of a row of entrenched and anchored straw bales.

2. Purpose

To intercept sheet flow and detain small amounts of sediment from disturbed areas.

3. Additional Information/Guidance

- Place straw bale barriers below disturbed areas subject to sheet and rill erosion.
- Straw bale barriers are more suitable for low-gradient slopes and small drainage areas.
- The longevity of the barrier is dependent on the time of year and climate.
- Under no circumstances should straw bale barriers be constructed in streams, channels, or ditches.

6A-2.29 Filter Berm

WSDOT Standard Specification

8-01.3(9)B – Gravel Filter, Wood Chip or Compost Berm

WSDOT Standard Plan

I-80.10-00 – Miscellaneous Erosion Control Details

1. Definition

A berm consisting of gravel, wood chips, or compost.

2. Purpose

Filter berms have two main functions: to prevent concentrated flows from damaging exposed cut/fill slopes and to provide perimeter containment of sediment at the toe of a slope.

3. Additional Information/Guidance
 - Construction vehicles and equipment can easily damage filter berms, so traffic must be routed around them.
 - To prevent blowouts, pipe slope drains may be needed to convey water that accumulates along the filter berm.

6A-2.30 Storm Drain Inlet Protection

WSDOT Standard Specification

8-01.3(9)D – Inlet Protection

WSDOT Standard Plan

I-40.20-00 – Storm Drain Inlet Protection

I-40.10-00 – Temporary Silt Fence for Inlet Protection in Unpaved Areas

1. Definition

A device or mechanism (internal or external) for trapping sediment within or immediately adjacent to a catch basin. Prefabricated devices are available for both situations.

2. Purpose

To prevent sediment from entering an enclosed drainage system where the material can be readily washed downstream. Inlet protection is often the last opportunity to minimize sediment impact to a receiving water body.

3. Additional Information/Guidance

- There is a difference in how internal and external inlet protection devices function.
- Internal devices tend to consist of a nonwoven material that is semiporous. Larger sediments are trapped, but silt and clay-sized particles pass through. They are most appropriate in situations where roadway flooding is a concern or construction traffic will damage an external device.
- External devices may be prefabricated or assembled in the field using silt fence. Both types trap sediment by creating a ponding area surrounding the inlet. The reduced velocities allow sediment to settle. This process allows external devices to be more efficient at trapping greater volumes of smaller-sized sediment.
- In an emergency, berms of sand bags or washed gravel can be placed around the inlet.

6A-2.31 Sediment Trap

WSDOT Standard Specification

No WSDOT Standard Specification exists, so a Special Provision must be written. For instructions on preparing Special Provisions, see the Introduction (6A-1).

WSDOT Standard Plan

I-80.10-00 – Miscellaneous Erosion Control Details

1. Definition

A small, temporary detention basin using a natural depression or constructed pond.

2. Purpose

To settle suspended sediments from concentrated flows.

3. Additional Information/Guidance

- Intended for use on sites where the tributary drainage area is less than 3 acres, with no unusual drainage features and with a projected build-out time of six months or less.
- Trap efficiency is enhanced when runoff is passed through multiple sediment control BMPs.
- Sediment traps are limited to removing silt/larger-sized sediment particles.
- Trap effectiveness increases with trap size.
- Sizing Procedure:
 - To determine the sediment trap geometry, first calculate the design surface area (SA) of the trap, measured at the invert of the weir. Use the following equation:

$$SA = FS(Q/V_s)$$
 where:
 - Q = Design inflow based on criteria contained in Section 4-3.3 for western Washington or Section 4-4.3 for eastern Washington.
 - V_s = The settling velocity of the soil particle of interest. The 0.02 mm (medium silt) particle with an assumed density of 2.65 g/cm³ has been selected as the particle of interest and has a settling velocity (V_s) of 0.00096 ft/sec.

$FS =$ A safety factor of 2 to account for nonideal settling.

Therefore, the equation for computing surface area becomes:

$$SA = 2 \times Q_2 / 0.00096 \text{ or} \\ 2080 \text{ square feet per cfs of inflow}$$

Note: Even if permanent facilities are used, they must still have a surface area that is at least as large as that derived from the above formula. If they do not, the pond must be enlarged.

- To aid in determining sediment depth, all sediment traps shall have a staff gage with a prominent mark 1 foot above the bottom of the trap.
- Sediment traps may not be feasible on utility projects due to the limited work space or the short-term nature of the work. Portable tanks may be used in place of sediment traps for utility projects.
- Sediment shall be removed from the trap when it reaches 1 foot in depth.
- Any damage to the pond embankments or slopes shall be repaired.

6A-2.32 Temporary Sediment Pond

WSDOT Standard Specification

8-01.3(1)E – Detention/Retention Pond Construction

1. Definition

A basin with a controlled stormwater release structure. Temporary sediment ponds are usually located where the permanent detention facilities are built. In such cases, more stringent permanent facility-sizing criteria are used to size temporary sediment ponds. All design criteria for permanent detention facilities should be applied to temporary ponds unless no permanent pond is to remain or be built.

2. Purpose

To collect stormwater runoff and detain it long enough to trap sediment.

3. Additional Information/Guidance

- The use of infiltration facilities for sedimentation basins clogs the soils and reduces infiltration capacity.
- Use sediment traps as pretreatment devices to minimize the need for pond maintenance and prevent soil clogging. If pretreatment is not possible, install a permeable rock divider within the pond.

- Pond outlets must be designed to provide flow control. WSDOT does not yet have a standard temporary pond outlet design. Design outlets in accordance with Figures 6A-1 to 6A-3. Contact the Region Hydraulics Office if site conditions warrant any modification of the figures.
- Structures having a maximum storage capacity at the top of the dam of 10 acre-ft (435,600 ft³) or more are subject to the Washington Dam Safety Regulations (Chapter 173-175 WAC).
- If permanent runoff control facilities are part of the project, consider using them for sediment retention during construction, if possible. The surface area requirements of the sediment basin must be met. This may require enlarging the permanent basin to comply with the surface area requirements. If a permanent control structure is used, it may be advisable to partially restrict the lower orifice with gravel to increase residence time while still allowing dewatering of the basin.

4. Sizing Procedure

- Determine the surface area (*SA*) of the sediment pond at the top of the riser pipe. Use the equation:

$$SA = 2 \times Q / 0.00096 \text{ or} \\ 2080 \text{ square feet per cfs of inflow}$$

For more information on the derivation of the surface area calculation, see Section 6A-2.31. Design inflow (*Q*) based on criteria contained in Section 4-3.3 for western Washington or Section 4-4.3 for eastern Washington.

- The basic geometry of the pond can now be determined using the following design criteria:
 - Minimum 3.5-foot depth from top of riser to bottom of pond.
 - Maximum 3H:1V interior side slopes and maximum 2H:1V exterior slopes. The interior slopes can be increased to a maximum of 2H:1V if fencing is provided at or above the maximum water surface.
 - One foot of freeboard between the top of the riser and the crest of the emergency spillway.
 - Flat bottom.
 - Minimum 1-foot-deep spillway.
 - Length-to-width ratio between 3:1 and 6:1.
- Sizing of Discharge Mechanisms.
 - The outlet for the basin consists of a combination of principal and emergency spillways. These outlets must pass the peak runoff

expected from the contributing drainage area for a 100-year storm. If, due to site conditions and basin geometry, a separate emergency spillway is not feasible, the principal spillway must pass the entire peak runoff expected from the 100-year storm. However, an attempt to provide a separate emergency spillway should always be made. The runoff calculations should be based on the site conditions during construction. The flow through the dewatering orifice cannot be utilized when calculating the 100-year storm elevation because of its potential to become clogged; therefore, available spillway storage must begin at the principal spillway riser crest.

- The principal spillway designed by the procedures contained in this standard will result in some reduction in the peak rate of runoff. However, the riser outlet design will not adequately control the basin discharge to the predevelopment discharge limitations as stated in Minimum Requirement 6, Flow Control. However, if the basin for a permanent stormwater detention pond is used for a temporary sedimentation basin, the control structure for the permanent pond can be used to maintain predevelopment discharge limitations. The size of the basin, the expected life of the construction project, the anticipated downstream effects and the anticipated weather conditions during construction should be considered to determine the need of additional discharge control. (See Figure FC.03.5 for riser inflow curves.)

Principal Spillway: Determine the required diameter for the principal spillway (riser pipe). The diameter shall be the minimum necessary to pass the site's 10-year, 15-minute peak flow (Q_{10}). For western WA, Q_{10} is the 10-year, 1-hour flow for the developed (unmitigated by flow control facilities) site, multiplied by a factor of 1.6. Use Figure FC.03.5 to determine this diameter ($h = 1$ foot). Note: A permanent control structure may be used instead of a temporary riser.

Emergency Overflow Spillway: Determine the required size and design of the emergency overflow spillway for the developed 100-year peak flow using the method contained in Chapter 4.

Dewatering Orifice: Determine the size of the dewatering orifice(s) (minimum 1-inch-diameter) using a modified version of the discharge equation for a vertical orifice and a basic equation for the area of a circular orifice. Determine the required area of the orifice with the following equation:

$$A_o = \frac{A_s (2h)^{0.5}}{0.6 \times 3600 T g^{0.5}}$$

where: A_o = orifice area (square feet)

A_s = pond surface area (square feet)

h = head of water above orifice (height of riser in feet)

T = dewatering time (24 hours)

g = acceleration of gravity (32.2 feet/second²)

Convert the required surface area to the required diameter D of the orifice:

$$D = 24x \sqrt{\frac{A_o}{\pi}} = 13.54x \sqrt{A_o}$$

The vertical perforated tubing connected to the dewatering orifice must be at least 2 inches larger in diameter than the orifice to improve flow characteristics. The size and number of perforations in the tubing should be large enough so that the tubing does not restrict flow. The orifice should control the flow rate.

- Additional Design Specifications
 - The **pond shall be divided** into two roughly equal volume cells by a permeable divider that will reduce turbulence while allowing movement of water between cells. The divider shall be at least one-half the height of the riser and a minimum of 1 foot below the top of the riser. Wire-backed, 2- to 3-foot-high, extra-strength filter fabric supported by treated 4x4s can be used as a divider. Alternatively, staked straw bales wrapped with filter fabric (geotextile) may be used. If the pond is more than 6 feet deep, a different mechanism must be proposed. A riprap embankment is one acceptable method of separation for deeper ponds. Other designs that satisfy the intent of this provision are allowed as long as the divider is permeable, structurally sound, and designed to prevent erosion under or around the barrier.
 - To aid in determining sediment depth, **1-foot intervals** shall be prominently marked on the riser.
 - If an **embankment** of more than 6 feet is proposed, the pond must comply with the criteria contained in BMP FC.03 regarding dam safety for detention BMPs.
- The most common structural failure of sedimentation basins is caused by piping. Piping refers to (1) water seeping through fine-grained soil, eroding the soil grain by grain and forming pipes or tunnels, and (2) water under

pressure flowing upward through a granular soil with a head of sufficient magnitude to cause soil grains to lose contact and capability for support.

- The most critical construction sequences to prevent piping will be:
 - Tight connections between riser and barrel and other pipe connections.
 - Adequate anchoring of riser.
 - Proper soil compaction of the embankment and riser footing.
 - Proper construction of antiseep devices.

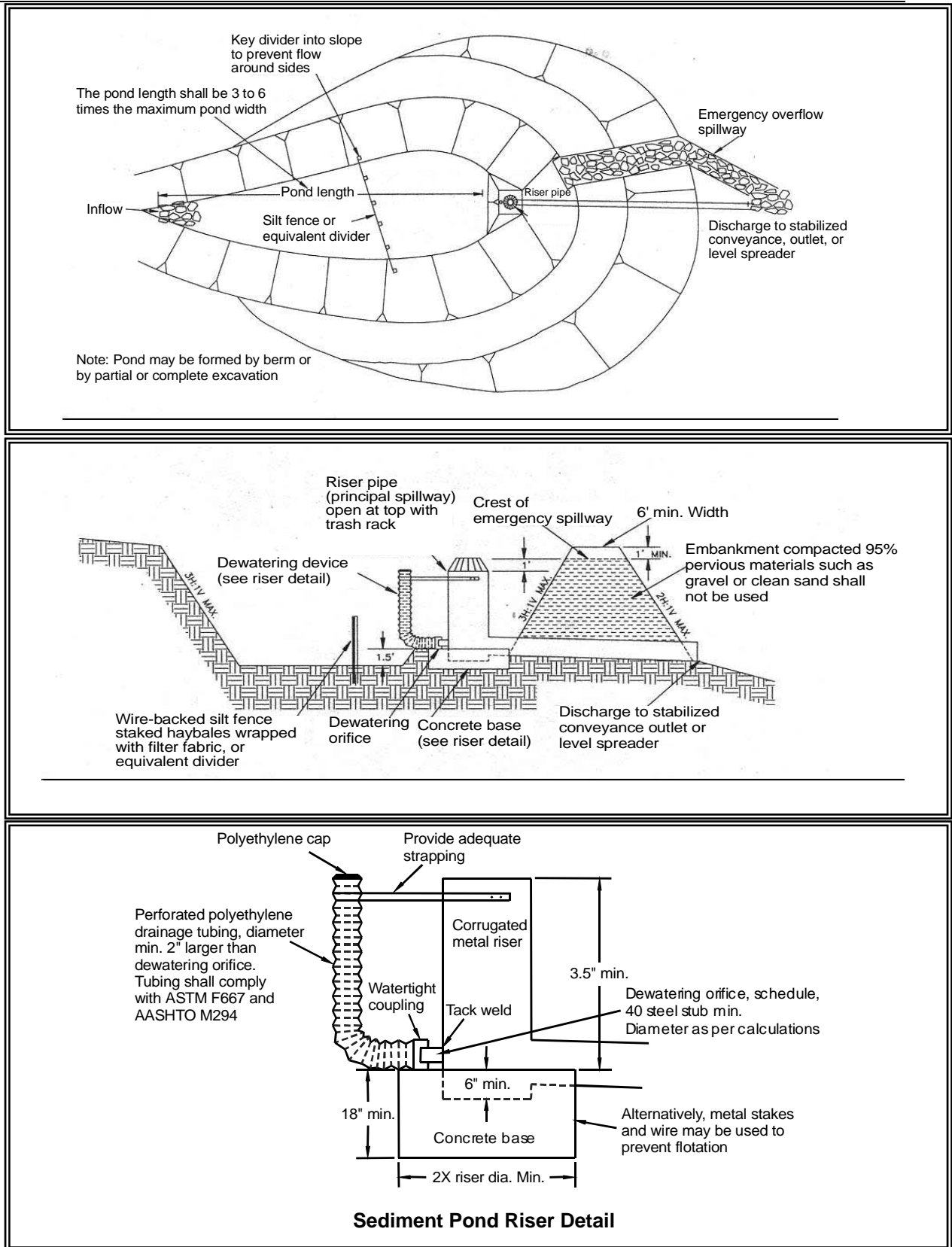

Figure 6A-1 Temporary sediment pond details.

6A-2.33 Concrete Handling

WSDOT Standard Specification

No WSDOT Standard Specification exists, so a Special Provision must be written. For instructions on preparing Special Provisions, see the Introduction (6A-1).

WSDOT has created a GSP for treatment of pH for concrete work, which is located at: www.wsdot.wa.gov/eesc/design/projectdev/GSPS/egsp8.htm. In situations where the GSP does not appear adequate, contact region environmental staff and the HQ Environmental Services Office (360-570-6649 or 360-570-6648) for more information or additional guidance for extreme situations where neutralizing the high pH water with dry ice or CO₂ sparging may be necessary.

1. Definition

A BMP designed to control concrete wastes and concrete leachate.

2. Purpose

To reduce the impact of fresh concrete on regulated water bodies that results from concrete work, including sawing, grinding, and resurfacing. Turbidity and pH are typically the water quality problems of concern with concrete work.

3. Additional Information/Guidance

- Stormwater inlet protection measures should be placed around all catch basins in the vicinity of concrete work.
- Performing concrete work in advance of storm events reduces the risk of generating concrete leachate and violating water quality standards.
- BMPs designed for spill prevention and containment can be used to eliminate the risk of discharging concrete runoff to receiving waters.

Areas designated to hold process water and to serve as tool-washing stations reduce the risk of concrete leachate being entrained in runoff. Cover these areas with plastic in advance of storms, if possible. Dewatering in such areas needs to be done in a way that does not violate water quality standards.

6A-2.34 High pH Neutralization

WSDOT Standard Specification

No WSDOT Standard Specification exists, so a Special Provision must be written. For additional information, contact region environmental staff or the HQ Environmental Services Office (360-570-6649 or 360-570-6648). For instructions on preparing Special Provisions, see the Introduction (6A-1).

1. Definition

The process of neutralizing stormwater when pH is over 8.5 pH units prior to discharge to waters of the state.

2. Purpose

When pH levels in stormwater rise above 8.5, it is necessary to lower the pH levels to the acceptable range of 6.5 to 8.5 prior to discharge to waters of the state. This process is called pH neutralization. Neutralized stormwater may be discharged to surface waters under the General Construction NPDES permit.

Process water includes wastewaters such as concrete truck wash-out, hydrodemolition, or saw-cutting slurry. Process water cannot be discharged to surface waters under the General Construction NPDES permit. Under certain circumstances, however, neutralized process water can be discharged. Contact the Region or HQ Environmental Office for more information.

3. Additional Information/Guidance

High pH stormwater can be treated by infiltration; dispersion in vegetation or compost (see Section 6A-2.20); pumping to a sanitary sewer; disposal at a permitted concrete batch plant; or carbon dioxide sparging (see methods below).

Methods for CO₂ sparging:

- Every effort should be made to isolate the high-pH water in order to treat it separately from other stormwater on-site.
- Transfer water to be treated to the treatment structure (baker tank). Ensure treatment structure size is sufficient to hold the amount of water to be treated.
- Sample the pH of the water. As a general rule, less CO₂ is needed for clearer water.
- In the pH adjustment structure (baker tank), add CO₂ until the pH drops as close to 7 as practicable. Compressed carbon dioxide gas should be introduced using a carbon dioxide diffuser located near the bottom of the tank.
- Release water, making sure that deposited sediment does not discharge in the process.
- Discharge water in a manner (such as dispersion, infiltration, or dilution in a pond or drainage system) that maximizes treatment potential prior to entering waters of the state.

- Dispose of sludge as concrete waste. If several batches of water are undergoing pH treatment, sludge can be left in the treatment structure. Dispose of sludge as necessary to ensure adequate storage volume and effective treatment.
- Operator Records: Include a diagram of the monitoring and treatment equipment and a description of the pumping rates and capacity the treatment equipment is capable of treating. Keep a record in the Site Log Book of the volume of water treated daily; the pH of untreated water; the amount of CO₂ needed to adjust water to as close to a pH of 7 as feasible; the pH of treated water; and the discharge point location and description.
- Refer to Ecology's SMMWW, Volume II, BMPs C252 and C253, for more information on neutralizing high pH.

6A-2.35 Construction Stormwater Chemical Treatment

WSDOT Standard Specification

No WSDOT Standard Specification exists, so a Special Provision must be written. Region environmental staff and the HQ Environmental Services Office (ESO) must be notified of the intent to use chemical treatment to determine whether it is necessary. For instructions on preparing Special Provisions, see the Introduction (6A-1).

1. Definition

The use of a chemical to encourage flocculation of fine sediments entrained in construction site runoff.

2. Conditions of Use

Chemical treatment must be approved by the HQ ESO Stormwater and Watersheds Program and region environmental staff. This ensures the environmental offices can:

- Provide input on whether or not chemical treatment is necessary or appropriate.
- Provide technical assistance.
- Ensure Ecology is properly notified.
- Track usage, effectiveness, and cost/benefit information.

Once written approval from Ecology is obtained, the chemical treatment system must be included in the TESC plan.

3. Purpose

Polymers improve the removal of fine sediment that would not normally settle out through gravity alone. Their usage is only warranted when:

- Large volumes of highly-turbid water cannot possibly be prevented due to unusual circumstances (such as projects requiring large dewatering/horizontal drilling operations or slides), and there is no reasonable possibility of effectively employing any standard sediment control BMP or dispersal/infiltration technique.
- Chemical treatment system costs enable the recovery of costs by other means, such as accelerated construction rates.

4. Additional Information

- This process is used in conjunction with stormwater filtration (refer to BMP 6A-2.36 below, Construction Stormwater Filtration).
- Refer to Ecology's SMMWW, Volume II, BMP C250, for more information on Chemical Treatment.

6A-2.36 Construction Stormwater Filtration

WSDOT Standard Specification

No WSDOT Standard Specification exists, so a Special Provision must be written. For instructions on preparing Special Provisions, see the Introduction (6A-1).

1. Definition

The process of pumping construction stormwater through a series of filters—primarily sand. Filters remove sediment from construction site stormwater by trapping sediment on or in filter media. Many of these systems are mobile and can be set up on any construction site.

2. Purpose

To remove sediment from construction site stormwater ponds that cannot be removed through other conventional means.

3. Additional Information/Guidance

- Unlike chemical treatment, the use of construction stormwater filtration does not require approval from Ecology.
- Two types of filtration systems may be applied to construction stormwater treatment: rapid and slow. Rapid sand filters are typically used for water and wastewater treatment. They can achieve relatively high hydraulic flow rates, on the order of 2 to 20 gallons per minute per square foot of filter area (gpm/sf), because they have automatic

backwash systems to remove accumulated solids. In contrast, slow sand filters have very low hydraulic flow rates, on the order of 0.02 gpm/sf, because they do not have backwash systems. To date, slow sand filtration has generally been used to treat stormwater. Slow sand filtration is mechanically simple in comparison to rapid sand filtration, but requires a much larger filter area.

- Filtration Equipment – Sand media filters are available with automatic backwashing features that can filter to 50 μm particle size. Screen or bag filters can filter down to 5 μm . Fiber-wound filters can remove particles down to 0.5 μm . Filters should be sequenced from the largest to the smallest pore opening. Sediment-removal efficiency is related to particle size distribution in the stormwater.
- Treatment Process Description – Stormwater is collected at interception point(s) on the site and diverted to a sediment pond or tank for removal of large sediment and storage of the stormwater before it is treated by the filtration system. The stormwater is pumped from the trap, pond, or tank through the filtration system in a rapid sand filtration system. Slow sand filtration systems are designed as flow-through systems using gravity.
- If large volumes of concrete are being poured, pH adjustment may be necessary.
- Filtration may also be used in conjunction with polymer treatment in a portable system to ensure capture of the flocculated solids.
- Refer to Ecology's SMMWW, Volume II, BMP C251, for more information on Chemical Treatment.

GLOSSARY OF TERMS

alignment Horizontal and vertical geometric elements that define the location of a roadway.

anadromous fish species Fish that are born and reared in freshwater, migrate to the ocean to grow to maturity, and return to freshwater to reproduce (such as salmon and steelhead).

anoxic Devoid of oxygen.

antecedent moisture conditions The degree of wetness of a watershed or the soil at the beginning of a storm.

antiseepage collar A device constructed around a pipe or other conduit and placed through a dam, levee, or dike for the purpose of reducing seepage losses and piping failures.

aquifer A geological stratum containing groundwater that can be withdrawn and used for human purposes.

arid Excessively dry; having insufficient rainfall to support agriculture without irrigation.

arterial A road or street intended to move high volumes of traffic over long distances at high speed, with partial control of access, having some intersections at grade. A *major arterial* connects an interstate highway to cities and counties. A *minor arterial* connects major arterials to collectors. A *collector* connects an arterial to a neighborhood (a collector is not an arterial). A *local access road* connects individual residences to a collector.

as-built drawings Engineering plans that have been revised to reflect all changes to the plans that occurred during construction.

average daily traffic (ADT) The volume of traffic passing a point on a highway in both directions during an average day of the year (or design year). ADT counts must be estimated using *Trip Generation*, published by the Institute of Transportation Engineers, or using a traffic study prepared by a professional engineer or transportation specialist with expertise in traffic volume estimation. ADT counts can be used to forecast future volumes for the design life of a particular project. For project sites with seasonal or varied use, the highest period of expected traffic impacts is evaluated.

backwater Water upstream from an obstruction that is deeper than it would normally be without the obstruction.

baffle A device to check, deflect, or regulate flow.

base flood A flood having a 1% chance of being equaled or exceeded in any given year (also called the 100-year flood).

base flow The portion of stream flow that is not attributable to storm runoff and is supported by groundwater seepage into a channel.

basic (water quality) treatment (versus *enhanced water quality treatment*) The Washington State Department of Ecology's performance goal is to achieve 80% removal of total suspended solids for influent concentrations that are greater than 100mg/l, but less than 200mg/l. For influent concentrations greater than 200mg/l, a higher treatment goal may be appropriate. For influent concentrations less than 100mg/l, the facilities are intended to achieve an effluent goal of 20mg/l total suspended solids.

basin The area of land drained by a river and its tributaries that drains water, organic matter, dissolved nutrients, and sediments into a lake or stream (see *watershed*). Basins typically range in size from 1 to 50 square miles.

basin plan A plan that assesses, evaluates, and proposes solutions to existing and potential future impacts on the physical, chemical, and biological properties and beneficial uses of waters of the state within a drainage basin. A plan should include but not be limited to recommendations for the following elements:

- Stormwater requirements for new development and redevelopment
- Capital improvement projects
- Land use management through identification and protection of critical areas, comprehensive land use and transportation plans, zoning regulations, site development standards, and conservation areas
- Source control activities, including public education and involvement, and business programs
- Other targeted stormwater programs and activities, such as maintenance, inspections, and enforcement
- Monitoring
- An implementation schedule and funding strategy

A basin plan that is adopted and implemented must have the following characteristics:

- Adoption by legislative or regulatory action of jurisdictions with responsibilities under the plan
- Recommended ordinances, regulations, programs, and procedures that are in effect or scheduled to go into effect
- An implementation schedule and funding strategy in progress

bench A relatively level step excavated into earth material on which fill is to be placed.

beneficial uses Those water uses identified in state water quality standards that must be achieved and maintained as required under the federal Clean Water Act. “Beneficial use” and “designated use” are often used interchangeably.

berm A constructed barrier of compacted earth, rock, or gravel. In a stormwater facility, a berm may serve as a vertical divider, typically built up from the bottom.

best available science The best available scientific knowledge and practices.

best management practices (BMPs) The structural devices, maintenance procedures, managerial practices, prohibitions of practices, and schedules of activities that are used singly or in combination to prevent or reduce the detrimental impacts of stormwater, such as pollution of water, degradation of channels, damage to structures, and flooding.

biodegradable Capable of being readily broken down by biological means, especially by microbial action. Microbial action includes the combined effects of bacteria, fungi, flagellates, amoebae, ciliates, and nematodes. Degradation can be rapid or may take many years, depending on such factors as available oxygen and moisture.

bioengineering The combination of biological, mechanical, and ecological concepts (and methods) to control erosion and stabilize soil through the use of vegetation alone or in combination with construction materials.

biofilter A designed treatment facility using a combined soil and vegetation system for filtration, infiltration, adsorption, and biological uptake of pollutants in stormwater when runoff flows over and through it. Vegetation growing in these facilities acts as both a physical filter that causes gravity settling of particulates by regulating velocity of flow, and as a biological sink when direct uptake of dissolved pollutants occurs. The former mechanism is probably the most important in western Washington, where the period of major runoff coincides with the period of lowest biological activity.

biofiltration The process of reducing pollutant concentrations in water by filtering the polluted water through biological materials, such as vegetation.

bioinfiltration The process of reducing pollutant concentrations in water by infiltrating the polluted water through grassy vegetation and soils into the ground.

biological assessment A document prepared under the direction of a federal agency to determine whether a proposed action involving major construction activities is likely to (1) adversely affect species protected under the Endangered Species Act or their designated critical habitats, (2) jeopardize the continued existence of species that are proposed for listing as threatened or endangered, or (3) adversely modify proposed critical habitat.

biological evaluation A document that contains exactly the same information as a biological assessment, evaluating the impacts of a proposed action on listed and proposed species and habitat. In the case of projects without federal involvement, the biological evaluation determines whether the proposed action would violate Section 9 of the Endangered Species Act. The biological evaluation can evolve into a biological assessment if formal or informal consultation is required with the federal agencies.

bioretention The removal of stormwater runoff pollutants using the chemical, biological, and physical properties afforded by a natural terrestrial community of plants, microbes, and soil. The typical bioretention system is set in a depressional area and consists of plantings, mulch, and an amended planting soil layer underlain with more freely draining granular material.

bituminous surface treatment (BST) A thin, protective wearing surface that is applied to a pavement or base course (also known as a seal coat or chip seal).

bollard A post (which may or may not be removable) used to prevent vehicular access.

borings Cylindrical samples of a soil profile used for analysis of soils or determination of infiltration capacity.

borrow area A source of earth fill material used in the construction of embankments or other earth fill structures.

buffer The zone contiguous with a sensitive area that is required for the continued maintenance, function, and structural stability of the sensitive area. The critical functions of a riparian buffer (those associated with an aquatic system) include shading; input of organic debris and coarse sediments; uptake of nutrients; stabilization of banks; interception of fine sediments; overflow during high water events; protection from disturbance by humans and domestic animals; maintenance of wildlife habitat; and room for variation of aquatic system boundaries over time due to hydrologic or climatic effects. The critical functions of terrestrial buffers include protection of slope stability, attenuation of surface water flows from stormwater runoff and precipitation, and erosion control.

bypass A channel or conveyance constructed to divert water around a stormwater facility or series of stormwater facilities.

capital costs Nonrecurring costs required to construct infrastructure, including costs of right of way, facilities, drainage systems, utilities, and associated administrative and design costs, as well as financing charges during construction.

capital improvement project or program (CIP) A project prioritized and scheduled as a part of an overall construction program or the actual construction program.

catch basin A chamber or well, usually built at the curb line of a street, for the admission of surface water to a sewer or subdrain, having at its base a sediment sump designed to retain grit and detritus below the point of overflow.

catch basin insert (CBI) A device installed under a storm drain grate to provide runoff treatment through filtration, settling, or adsorption (also called *inlet protection*).

catchment Surface area associated with pavement drainage design.

cation exchange capacity (CEC) The amount of exchangeable cations that a soil can adsorb at pH 7.0, typically expressed in units of milliequivalents per 100 grams of dry soil.

channel A feature that conveys surface water and is open to the air.

channel erosion The widening, deepening, and headward cutting of small channels and waterways resulting from erosion caused by moderate-to-large floods.

channel stabilization Erosion prevention and stabilization of velocity distribution in a channel using vegetation, jetties, drops, revetments, or other measures.

check dam A small dam constructed in a ditch, gully, grass swale, or other small watercourse to decrease the stream flow velocity, enhance infiltration, minimize channel scour, and promote deposition of sediment; or a log or gabion structure placed perpendicular to a stream to enhance aquatic habitat.

clearing The removal and disposal of all unwanted natural material from the ground surface such as trees, brush, and downed timber by manual, mechanical, or chemical methods.

closed depression A low-lying area that has either no surface water outlet or such a limited surface water outlet that, during storm events, the area acts as a retention basin.

coir Coconut fiber used for erosion control blankets and wattles.

compaction The densification, settlement, or packing of soil in such a way that its permeability is reduced. Compaction effectively shifts the performance of a hydrologic group to a lower-permeability hydrologic group. Compaction may also refer to the densification of a fill by mechanical means.

compost Organic residue, or a mixture of organic residues and soil, that has undergone biological decomposition until it has become relatively stable humus. The Washington State Department of Ecology's *Interim Guidelines for Compost Quality* (1994) defines compost as "the product of composting; it has undergone an initial, rapid stage of decomposition and is in the process of humification (curing)." Compost to be used should meet specifications shown in Standard Specification 9-14.4(8).

concentrated flow Water flowing in a channel as opposed to a thin sheet.

constructed stormwater treatment wetland A wetland intentionally created on a site that is not a wetland, for the primary purpose of wastewater or stormwater treatment. Constructed wetlands are normally considered part of the stormwater collection and treatment system.

Construction Contract Information System (CCIS) A WSDOT database managed by the HQ Construction Office to track contract costs.

construction staging area A site used temporarily during construction for materials or equipment storage, assembly, or other temporary construction activities.

context sensitive design (CSD) A collaborative, interdisciplinary approach that involves all stakeholders in developing a transportation facility that fits its physical setting and preserves scenic, aesthetic, historic, and environmental resources while maintaining safety and mobility (also known as "context sensitive solutions" and "thinking beyond the pavement").

converted pervious surface Land cover changed from native vegetation to lawn, landscape, or pasture areas. (See also *pollution-generating impervious surface*.)

conveyance A mechanism for transporting water from one point to another, including pipes, ditches, and channels.

conveyance system The drainage facilities, both natural and constructed, that collect, contain, and provide for the flow of surface water and stormwater from the highest points on the land down to a receiving water. The natural elements of the conveyance system include swales and small drainage courses, streams, rivers, lakes, and wetlands. Constructed elements of the conveyance system include gutters, ditches, pipes, channels, and most retention/ detention facilities.

critical areas At a minimum: areas that include wetlands; areas with a critical recharging effect on aquifers used for potable water; fish and wildlife habitat conservation areas; frequently flooded areas; geologically hazardous areas, including unstable slopes; and associated areas and ecosystems.

culvert A pipe or concrete box structure that drains open channels, swales, or ditches under a roadway or embankment. Typically, a culvert is not connected to a catch basin or manhole along its length. Various types of culverts are listed in the *Hydraulics Manual*.

cut-and-fill The process of moving earth by excavating part of an area and using the excavated material for adjacent embankments or fill areas.

cut slope A slope formed by excavating overlying material to connect the original ground surface with a lower ground surface created by the excavation. A cut slope is distinguished from a bermed slope, which is constructed by importing soil to create the slope.

dangerous waste Any discarded, useless, unwanted, or abandoned substances, including (but not limited to) certain pesticides, or any residues or containers of such substances that are disposed of in such quantity or concentration as to pose a substantial current or potential hazard to human health, wildlife, or the environment (RCW 70.105.010). These wastes may have short-lived, toxic properties that may cause death, injury, or illness; may have mutagenic, teratogenic, or carcinogenic properties; may be corrosive, explosive, or flammable; or may generate pressure through decomposition or other means. (See also *hazardous waste*.)

dead storage The volume of water in a pond, reservoir, or infiltration facility that is stored below the elevation of the lowest outlet or operating level of the structure; the volume available in a depression in the ground below any conveyance system, surface drainage pathway, or outlet invert elevation that could allow the discharge of surface and stormwater runoff.

demonstrative approach (versus *presumptive approach*) See Sections 1-1.3 and 5-3.5.3.

depression storage The amount of precipitation trapped in depressions on the surface of the ground.

design flow rate The maximum flow rate to which certain runoff treatment BMPs are designed for required pollutant removal. Biofiltration swales, vegetated filter strips, and oil/water separators are some of the runoff treatment BMPs that are sized based on a design flow rate.

design storm A rainfall event of specified size and return frequency that is used to calculate the runoff volume and peak discharge rate to a stormwater facility. A prescribed hyetograph and total precipitation amount (for a specific duration recurrence frequency) are used to estimate runoff for a hypothetical storm for the purposes of analyzing existing drainage, designing new drainage facilities, or assessing other impacts of a proposed project on the flow of surface water. (A hyetograph is a graph of percentages of total precipitation for a series of time steps representing the total time during which the precipitation occurs.)

design storm frequency The anticipated period in years that will elapse before a storm of a given intensity or total volume will recur, based on the average probability of storms in the design region. For instance, a 10-year storm can be expected to occur on the average once every 10 years. Facilities designed to handle flows that occur under such storm conditions would be expected to be surcharged by any storms of greater amount or intensity.

design volume For western Washington, the water quality design volume is the 91st percentile, 24-hour runoff volume indicated by MGSFlood or an approved continuous runoff model (see Table 3-3). In eastern Washington, the water quality design volume is the volume of runoff predicted from a 24-hour storm with a 6-month return frequency (see Table 3-4).

detention The temporary storage of stormwater runoff in a stormwater facility, which is used to control the peak discharge rates and provide gravity settling of pollutants; the release of stormwater runoff from the site at a slower rate than it is collected by the stormwater facility system, with the difference held in temporary storage.

detention facility An aboveground or below-grade ground facility, such as a pond or tank, that temporarily stores stormwater runoff and subsequently releases it at a slower rate than it is collected by the drainage facility system. There is little or no infiltration of stored stormwater.

dewatering Removing water by pumping, drainage, or evaporation.

discharge Runoff leaving a new development or redevelopment via overland flow, built conveyance systems, or infiltration facilities; a hydraulic rate of flow, specifically fluid flow; or a volume of fluid passing a point per unit of time, commonly expressed in cubic feet per second, cubic meters per second, gallons per minute, gallons per day, or millions of gallons per day.

dispersion Release of surface water and stormwater runoff in such a way that the flow spreads over a wide area and is located so as not to allow flow to concentrate anywhere upstream of a drainage channel with erodible underlying granular soils.

displacement A property encroachment that requires full acquisition of a parcel in order to build and operate public transportation facilities.

ditch A long, narrow excavation dug in the earth for drainage, having a top width less than 10 feet at design flow.

drainage easement A legal encumbrance placed against a property's title to reserve specified privileges for the users and beneficiaries of the drainage facilities contained within the boundaries of the easement.

drawdown The gradual reduction in water level in a pond due to the combined effects of infiltration and evaporation; the lowering of the water surface (in open-channel flow), the water table, or the piezometric surface (in groundwater flow) resulting from a withdrawal of water.

drop structure A structure for dropping water to a lower level and dissipating its surplus energy (a fall). A drop may be vertical or inclined.

dry pond A facility that provides stormwater quantity control by containing excess runoff in a detention basin, then releasing the runoff at allowable levels.

dry vault or tank A facility that provides stormwater quantity control by detaining runoff in underground storage units and then releasing reduced flows at established standards.

drywell A well completed above the water table so that its bottom and sides are typically dry except when receiving fluids. Drywells are designed to disperse water below the land surface and are commonly used for stormwater management in eastern Washington. (See also *underground injection control [UIC] well*.)

duff The naturally-occurring layer of dead and decaying plant material that develops on the ground surface under established plant communities.

easement The legal right to use a parcel of land for a particular purpose. It does not include fee ownership, but may restrict the owner's use of the land.

eastern Washington high-use road Eastern Washington roadways with ADT >30,000.

Ecology Washington State Department of Ecology.

ecology embankment *See media filter drain.*

effective impervious surface For determining whether a particular TDA has exceeded Minimum Requirement 6 (Flow Control), the net-new impervious surfaces plus

any applicable replaced impervious surfaces minus those new and applicable replaced impervious surfaces that are flowing into an existing dispersion area (noneffective new impervious surfaces and noneffective replaced impervious surfaces).

effective impervious surface = net new impervious surface + applicable replaced impervious surface – noneffective new impervious surface – noneffective replaced impervious surface

effective pollution-generating impervious surface (PGIS) For determining whether a particular TDA has exceeded Minimum Requirement 5 (Runoff Treatment), the new PGIS plus applicable replaced PGIS minus those new PGIS areas and applicable replaced PGIS areas that are flowing into an existing dispersion area (noneffective new PGIS and noneffective replaced PGIS).

effective PGIS = new PGIS + applicable replaced PGIS – noneffective new PGIS – noneffective replaced PGIS

embankment A structure of earth, gravel, or similar material raised to form a pond bank or foundation for a road.

emergency overflow spillway A vegetated earth or rock-lined channel used to safely convey flood discharges in excess of the capacity of the principal spillway.

emergent plants Aquatic plants that are rooted in the sediment but whose leaves are at or above the water surface. These wetland plants often have high habitat value for wildlife and waterfowl and can aid in pollutant uptake.

emerging BMP technologies BMP technologies that have not been evaluated using approved protocols, but for which preliminary data indicate they may provide a desirable level of stormwater pollutant removal. In some instances, an emerging technology may have already received a *pilot use* or *conditional use designation* from the Washington State Department of Ecology, but does not have a *general use designation*.

endangered species Any species in danger of extinction throughout all or a significant portion of its range (other than pest insects).

Endangered Species Act (ESA) of 1973 An act “*To provide for the conservation of endangered and threatened species of fish, wildlife, and plants, and for other purposes.*”

energy dissipater A means by which the total energy of flowing water is reduced, such as rock splash pads, drop manholes, concrete stilling basins or baffles, and check dams. In stormwater design, an energy dissipater is usually a mechanism that reduces velocity prior to or at discharge from an outfall in order to prevent erosion.

engineering and economic feasibility (EEF) An assessment of whether a project will experience practical limitations in fully meeting certain minimum requirements, particularly runoff treatment and flow control, within the project right of way. Limitations may be infrastructural, geographical, geotechnical, hydraulic, environmental, or benefit/cost-related. (Chapter 2 provides further discussion of EEF, and Appendix 2A includes the EEF Checklist, which is designed to identify the critical limiting factors that may inhibit or preclude construction of stormwater management facilities in a project right of way).

enhanced runoff treatment, enhanced water quality treatment (versus *basic water quality treatment*) The use of runoff treatment BMPs designed to capture dissolved metals at a higher rate than basic treatment BMPs.

ephemeral stream A stream or portion of a stream that flows in direct response to precipitation, receiving little or no water from groundwater or snowmelt (also known as a seasonal stream).

equivalent area An impervious surface area equal in size, located in the same drainage basin (threshold discharge area), and having similar use characteristics (for example, similar average daily traffic) to the impervious surface. The equivalent area concept generally applies to *engineered dispersion* areas and may apply to *natural dispersion* areas, as described in the following: The existing site currently collects runoff in a ditch or pipe and discharges to a surface water. By changing this condition to natural dispersion (BMP FC.01), a surface discharge is eliminated, resulting in a flow control improvement. Equivalent area trades for natural dispersion are allowed for this specific case.

erosion The detachment and movement of soil or rock fragments by water, wind, ice, or gravity.

erosion control blanket A blanket made of natural plant material or synthetic fibers that is rolled out and fastened to the soil surface to protect soil from raindrop and sheet erosion.

erosion and sedimentation control (ESC) Any temporary or permanent measures taken to reduce erosion, trap sediment, and ensure sediment-laden water does not leave the site.

estuarine wetland Generally, an eelgrass bed, salt marsh, or rocky sand flat or mudflat intertidal area where freshwater and saltwater mix (specifically, a tidal wetland with salinity greater than 0.5 parts per thousand, usually partially enclosed by land, but with partially obstructed or sporadic access to the open ocean).

eutrophication The addition of nutrients, especially nitrogen and phosphorus, to a body of water, resulting in high organic production rates that may overcome natural self-purification processes. Frequently resulting from pollutant sources on adjacent lands, eutrophication produces undesirable effects, including algal blooms, seasonally low oxygen levels, and reduced survival opportunities for fish and invertebrates.

evapotranspiration The collective term for the processes of evaporation and plant transpiration by which water is returned to the atmosphere.

exfiltration The downward movement of runoff through the bottom of an infiltration facility into the soil layer, or the downward movement of water through soil.

existing land cover/existing site conditions The conditions (ground cover, slope, drainage patterns) of a site as they existed on the first day the project entered the design phase.

existing roadway prism The limit of embankment or excavation work required to construct the roadway. This limit is further defined as the catch point of a cut or fill with the existing ground.

feasibility See *engineering and economic feasibility*.

fill slope An embankment made of earthen material placed by artificial means that is especially vulnerable to erosion.

filter berm A berm of compost, mulch, or gravel to detain and filter sediment from sheet flow.

filter fabric A woven or nonwoven water-permeable material, typically made of synthetic products such as polypropylene, used in stormwater management and erosion and sediment control applications to trap sediment or to prevent fine soil particles from clogging the aggregates.

filter strip A grassy area with gentle slopes that treats stormwater runoff from adjacent paved areas before it can concentrate into a discrete channel.

fish-bearing stream According to WAC 222-16-030: Type S, F, and Np waters are fish habitat streams. Until fish habitat water type maps are available, an interim water-typing system applies (see WAC 222-16-031). Type 1, 2, 3, and 4 waters are fish habitat streams.

flood An overflow or inundation that comes from a river or any other source, including but not limited to streams, tides, wave action, storm drains, or excess rainfall; any relatively high stream flow overtopping the natural or artificial banks in any reach of a stream.

flood control project A structural system installed to protect land and improvements from floods by the construction of dikes, river embankments, channels, or dams.

flood frequency The frequency at which the flood of interest may be expected to occur.

flood peak The highest value of the stage or discharge attained by a flood; thus, peak stage or peak discharge.

floodplain The total area subject to inundation by a flood, including the flood fringe and floodway.

flood stage The stage at which overflow of the natural banks of a stream begins.

floodway The channel of the river or stream and those portions of the adjoining floodplains that are reasonably required to carry and discharge the base flood flow. The "reasonably required" portion of the adjoining floodplains is defined by flood hazard regulations.

flow control (formerly called *water quantity treatment or detention*)

flow control facility A drainage facility (BMP) designed to mitigate the impacts of increased surface water and stormwater runoff flow rates generated by development. Flow control facilities are designed to either hold water for a considerable length of time and then release it by evaporation, plant transpiration, or infiltration into the ground, or to hold runoff for a short period of time and then release it to the conveyance system at a controlled rate.

flow duration The aggregate time that peak flows are equal to or above a particular flow rate of interest. For example, the amount of time that peak flows are equal to or above 50% of the 2-year peak flow rate for a period of record.

flow frequency The inverse of the probability that the flow will be equaled or exceeded in any given year (the exceedance probability). For example, if the exceedance probability is 0.01 or 1 in 100, that flow is referred to as the 100-year flow.

flow path The route that stormwater runoff follows between two points of interest.

flow rate The amount of a fluid passing a certain point in a given amount of time. In stormwater applications it is usually expressed in cubic feet per second or gallons per minute.

flow splitter A device with multiple outlets, each sized to pass a specific flow rate at a given head.

flow spreader A device with a wide enough outlet to efficiently distribute concentrated flows evenly over a large area, having common components such as trenches, perforated pipes, and berms.

forebay An easily maintained extra storage area provided near an inlet of a stormwater facility to trap incoming sediments before they accumulate in a pond or wetland.

freeboard The vertical distance between the design water surface elevation and the elevation of the barrier that contains the water.

functions, wetland The ecological (physical, chemical, and biological) processes or attributes of wetlands without regard for their importance to society. Wetland functions include food chain support; provision of ecosystem diversity and fish and wildlife habitat; flood flow alteration; groundwater recharge and discharge; water quality improvement; and soil stabilization.

gabion A rectangular or cylindrical wire mesh cage (a chicken wire basket) filled with rock and used as a protection or revetment against erosion. Soft gabions, often used in streams and ponds to stabilize banks or change flow patterns, are made of geotextiles filled with soil, with cuttings placed between.

gage or gauge A device for registering precipitation, water level, discharge, velocity, pressure, or temperature. Also, a measure of the thickness of metal (for example, diameter of wire or wall thickness of steel pipe).

geologically hazardous areas Areas that, because of their susceptibility to erosion, sliding, earthquakes, or other geological events, are not suited to the siting of commercial, residential, or industrial development consistent with public health or safety concerns.

geologist A person who has earned a degree in geology from an accredited college or university (or who has equivalent educational training) and has at least five years of experience as a practicing geologist or four years of experience in practice and at least two years of post-graduate study, research, or teaching. The practical experience must include at least three years working in applied geology and landslide evaluation, in close association with qualified practicing geologists or geotechnical professional/civil engineers.

geotextile Durable synthetic fabrics used to reinforce soils and construct temporary sediment control BMPs for detaining runoff and trapping sediment.

GIS Workbench An ArcView geographic information system tool maintained by the WSDOT HQ Geographic Services Office and the HQ Office of Information Technology to provide staff with access to comprehensive, current, and detailed environmental and natural resource management data.

gore area The tapering paved area between two lanes, on which travel is not allowed.

grade The slope of a road, channel, or natural ground; the finished surface of a canal bed, roadbed, top of embankment, or bottom of excavation; or any surface prepared for the support of construction such as paving or the laying of a conduit.

gradient terrace A terrace cut horizontally into a slope, designed according to criteria that consider slope, length, and height.

groundwater Water in a saturated zone or stratum beneath the land surface or a surface water body.

groundwater recharge Inflow to a groundwater reservoir.

groundwater table The free surface of the groundwater, which is subject to atmospheric pressure under the ground and is seldom static, generally rising and falling with the season, the rate of withdrawal, the rate of restoration, and other conditions.

grubbing The removal and disposal of all unwanted vegetative matter from underground, such as sod, stumps, roots, buried logs, or other debris.

gully A channel caused by the concentrated flow of surface and stormwater runoff over unprotected erodible land.

habitat The specific area or environment in which a particular type of plant or animal lives. An organism's habitat must provide all the basic requirements for life and should be protected from harmful biological, chemical, and physical alterations.

hardpan A cemented or compacted and often clay-like layer of soil that is impenetrable by roots (also known as glacial till).

hazardous substance Any liquid, solid, gas, or sludge, including any material, substance, product, commodity, or waste, regardless of quantity, that exhibits any of the characteristics or criteria of hazardous waste (RCW 70.105.010). (See also *dangerous waste*.)

hazardous waste All dangerous and extremely hazardous waste, including substances having radioactive or hazardous components (RCW 70.105.010). (See also *dangerous waste*.)

head (hydraulic) The height of water above any plane of reference; the energy, either kinetic or potential, possessed by each unit weight of a liquid, expressed as the vertical height through which a unit weight would have to fall to release the average energy possessed; used in various compound terms such as pressure head, velocity head, and head loss.

heavy metals Metals of high specific gravity, present in municipal and industrial wastes, that pose long-term environmental hazards. Such metals include cadmium, chromium, cobalt, copper, lead, mercury, nickel, and zinc.

high-use roadway and parking area Roadways and parking areas that the Washington State Department of Ecology presumes will generate concentrations of oil that need to be managed. With respect to oil control, absorptive BMPs (CAVFS, bioinfiltration pond) should be used on these high-use roads and parking areas. Examples of high-use roadways and parking areas include the following:

- Rest areas with an expected trip end count greater than or equal to 300 vehicles per day
- Eastern Washington roads with ADT > 30,000

high-use site, high-use intersection A site that the Washington State Department of Ecology presumes will generate high concentrations of oil due to high traffic turnover or the frequent transfer of oil. Examples of high-use sites include the following:

- An intersection where either $\geq 15,000$ vehicles (ADT) must stop to cross a roadway with $\geq 25,000$ vehicles (ADT) or vice versa
- Maintenance facilities that park, store, or maintain 25 or more vehicles (trucks or heavy equipment) that exceed 10 tons gross weight each

highway A main public road connecting towns and cities.

historic land cover The native vegetation and soils that existed at a site prior to the influence of Euro-American settlement. The predeveloped condition shall be assumed to be forested land cover unless reasonable historic information is provided that indicates the site was prairie prior to settlement.

hog fuel Wood residues processed through a chipper or mill to produce coarse chips. Residues may include bark, sawdust, planer shavings, wood chunks, and small amounts of mineral material.

hydraulic conductivity The quality of saturated soil that enables water or air to move through it (also known as permeability coefficient).

hydraulic gradient Slope of the potential head relative to a fixed datum.

hydraulic residence time The time required for a slug of water to move through a system. In the most simplistic situation, once inflows to a water body cease, the hydraulic residence time is equal to the volume of the water body divided by the discharge rate (assuming no short-circuiting of the system).

hydrograph A graph of runoff rate, inflow rate, or discharge rate past a specific point over time.

Hydrological Simulation Program–Fortran (HSPF) A continuous simulation hydrologic model that transforms an uninterrupted rainfall record into a concurrent series of runoff or flow data by means of a set of mathematical algorithms that represent the rainfall-runoff process at some conceptual level.

hydrologic cycle The circuit of water movement from the atmosphere to the earth and returning to the atmosphere through various stages or processes such as precipitation, interception, runoff, infiltration, percolation, storage, evaporation, and transpiration.

hydrologic soil groups A soil characteristic classification system defined by the U.S. Soil Conservation Service in which a soil may be categorized into one of four soil groups (A, B, C, or D) based upon infiltration rate and other properties (based on *Water Quality Prevention, Identification, and Management of Diffuse Pollution* by Vladimir Novotny and Harvey Olem; Van Nostrand Reinhold, New York, 1994, page 109). Soil groups include:

- **Type A** – Low runoff potential. Soils having high infiltration rates, even when thoroughly wetted and consisting chiefly of deep, well-drained to excessively-drained sands or gravels. These soils have a high rate of water transmission.
- **Type B** – Moderately low runoff potential. Soils having moderate infiltration rates when thoroughly wetted and consisting chiefly of moderately fine to moderately coarse textures. These soils have a moderate rate of water transmission.
- **Type C** – Moderately high runoff potential. Soils having slow infiltration rates when thoroughly wetted and consisting chiefly of soils with a layer that impedes downward movement of water, or soils with moderately fine to fine textures. These soils have a slow rate of water transmission.
- **Type D** – High runoff potential. Soils having very slow infiltration rates when thoroughly wetted and consisting chiefly of clay soils with a high swelling potential; soils with a permanent high water table; soils with a hardpan, till, or clay layer at or near the surface; soils with a compacted subgrade at or near the surface; and shallow soils or nearly impervious material. These soils have a very slow rate of water transmission.

hydrology The science of the behavior of water in the atmosphere, on the surface of the earth, and below ground.

hydroperiod A seasonal occurrence of flooding or soil saturation; it encompasses the depth, frequency, duration, and seasonal pattern of inundation.

hyetograph A graph of percentages of total precipitation for a series of time steps representing the total time during which the precipitation occurs.

illicit discharge All nonstormwater discharges to stormwater drainage systems that cause or contribute to a violation of state water quality, sediment quality, or groundwater quality standards, including but not limited to sanitary sewer connections, industrial process water, interior floor drains, car washing, and gray-water systems.

impaired waters Water bodies not fully supporting their beneficial uses, as defined under the federal Clean Water Act, Section 303(d). (See the Washington State Department of Ecology 303(d) list at: www.ecy.wa.gov/programs/wq/303d/.)

impervious surface A hard surface area that either prevents or retards the entry of water into the soil mantle as occurs under natural conditions (prior to development) and from which water runs off at an increased rate of flow or in increased volumes. Common impervious surfaces include but are not limited to rooftops, walkways, patios, driveways, parking lots, storage areas, concrete or asphalt paving, gravel roads, packed earthen materials, and oiled or macadam surfaces. Open, uncovered retention/detention facilities are not considered impervious surfaces for the purpose of determining whether the thresholds for application of minimum requirements are exceeded. Open, uncovered retention/detention facilities are considered impervious surfaces for the purpose of runoff modeling.

Implementing Agreement The Implementing Agreement between the Washington State Department of Ecology and the Washington State Department of Transportation Regarding Compliance with the State of Washington Surface Water Quality Standards (also abbreviated as WQIA: Water Quality Implementing Agreement).

impoundment A natural or constructed containment for surface water.

improvement Streets (with or without curbs or gutters), sidewalks, crosswalks, parking lots, water mains, sanitary and storm sewers, drainage facilities, street trees, and other appropriate items.

infiltration The downward movement of water from the surface to the subsoil.

infiltration facility or system A drainage facility designed to use the hydrologic process of surface and stormwater runoff soaking into the ground (commonly called percolation), to dispose of surface and stormwater runoff.

infiltration pond A facility that provides stormwater quantity control by containing excess runoff in a detention facility, then percolating that runoff into the surrounding soil.

infiltration rate The rate, usually expressed in inches per hour, at which water moves downward (percolates) through the soil profile. Short-term infiltration rates may be inferred from soil analysis or texture or derived from field measurements. Long-term infiltration rates are affected by variability in soils and subsurface conditions at the site, the effectiveness of pretreatment or influent control, and the degree of long-term maintenance of the infiltration facility.

inlet A form of connection between the surface of the ground and a drain or sewer for the admission of surface and stormwater runoff.

interception (hydraulic) The process by which precipitation is caught and held by foliage, twigs, and branches of trees, shrubs, and other vegetation. Often used to mean interception loss or the amount of water evaporated from the precipitation intercepted.

interceptor dike A soil berm used to intercept and redirect stormwater runoff to a treatment facility.

interflow That portion of rainfall that infiltrates into the soil and moves laterally through the upper soil horizons until intercepted by a stream channel or until it returns to the surface; for example, in a roadside ditch, wetland, spring, or seep. Interflow is a function of soil system depth, permeability, and water-holding capacity.

intermittent stream or channel A stream or portion of a stream that flows only in direct response to precipitation; receives little or no water from springs and no continual supply from melting snow or other sources; and is dry for a large part of the year, ordinarily more than three months.

invert The lowest point on the inside of a sewer or other conduit.

invert elevation The vertical elevation of a pipe or orifice in a pond that defines the water level.

isopluvial map A map with lines representing constant depth of total precipitation for a given return frequency.

lake An area permanently inundated by water in excess of two meters deep and greater than 20 acres in size as measured at the ordinary high water marks.

land-disturbing activity Any activity that results in a movement of earth or a change in the existing soil cover (both vegetative and nonvegetative) or the existing soil topography, including but not limited to clearing, grading, filling, and excavation. Compaction that is associated with stabilization of structures and road construction is also considered a land-disturbing activity. Vegetation maintenance practices are not considered land-disturbing activities.

landslide hazard areas Those areas subject to a severe risk of landslide.

leachate Liquid that has percolated through soil and contains substances in solution or suspension.

level pool routing The basic technique of storage routing used for sizing and analyzing detention storage and determining water levels for ponding water bodies. The level pool routing technique is based on the continuity equation: inflow – outflow = change in storage.

level spreader A temporary erosion and sedimentation control device used to distribute stormwater runoff uniformly over the ground surface as sheet flow (not through channels), in order to enhance infiltration and prevent concentrated, erosive flows.

live storage The volume of the flow control BMP that is released over a long period of time.

local government, local jurisdiction Any county, city, town, or special-purpose district having its own incorporated government for local affairs.

low-impact development (LID) An evolving approach to land development and stormwater management that uses a site's natural features and specially designed BMPs to manage stormwater; it involves assessing and understanding the site, protecting native vegetation and soils, and minimizing and managing stormwater at the source. Low-impact development practices are appropriate for a variety of development types.

low-permeability liner A layer of compacted till or clay or a geomembrane.

Manning's equation An equation used to predict the velocity of water flow in a pipeline or an open channel:

$$V = (1.486(R^{2/3})(S^{1/2}))/n$$

where:

V = the mean velocity of flow in feet per second

R = the hydraulic radius in feet

S = the slope of the energy gradient or, for assumed uniform flow, the slope of the channel in feet per foot

n = Manning's roughness coefficient or retardance factor of the channel lining

media filter A filter that includes material for removing pollutants (such as compost, gypsum, perlite, zeolite, or activated carbon).

media filter drain (previously known as the ecology embankment) A stormwater treatment facility typically constructed in the pervious shoulder area of a highway, consisting of a no-vegetation zone, a grass strip, a filter media mix, and a drain component that keeps the facility free draining.

mitigated area The drainage area from which stormwater runoff is to be detained or treated.

mitigation Measures to reduce adverse impacts on the environment, in the following order of preference:

1. Avoid the impact altogether by not taking a certain action or part of an action.
2. Minimize the impact by limiting the degree or magnitude of the action and its implementation, by using appropriate technology, or by taking affirmative steps to avoid or reduce impacts.
3. Rectify the impact by repairing, rehabilitating, or restoring the affected environment.
4. Reduce or eliminate the impact over time by preservation and maintenance operations during the life of the action.
5. Compensate for the impact by replacing, enhancing, or providing substitute resources or environments.

mitigation wetland A wetland that is created, enhanced, restored, or preserved to offset the unavoidable environmental impacts of development actions on natural wetlands.

monitoring The collection of data by various methods for the purposes of understanding natural systems and features, evaluating the impacts of development proposals on such systems, and assessing the performance of mitigation measures imposed as conditions of development.

National Pollutant Discharge Elimination System (NPDES) The part of the federal Clean Water Act that requires point source dischargers to obtain permits, called NPDES permits, which in Washington State are administered by the Washington State Department of Ecology.

native growth protection easement (NGPE) An easement granted for the protection of native vegetation within a sensitive area or its associated buffer. The easement should be recorded on the appropriate documents of title and filed with the county records division.

native vegetation Vegetation consisting of plant species other than noxious weeds that are indigenous to the region and that could be reasonably expected to occur naturally on the site.

Natural Resources Conservation Service (NRCS) curve number A number that describes the runoff characteristics of a particular soil type.

new impervious surfaces Those surfaces that receive direct, run-on, or blow-in of rainfall and (1) expand the existing roadway prism or (2) are upgraded from gravel to bituminous surface treatment (BST), asphalt, or concrete pavement. Note that existing gravel surfaces are considered impervious surfaces. However, a gravel surface that is upgraded to a more impervious surface (gravel to BST, ACP, or PCCP) is defined as a new impervious surface.

net-new impervious surface The total area of new impervious surface being added to the TDA minus the total area of existing impervious surface being removed from the TDA. In order to use this concept, the existing impervious surface removal area must fully revert to a natural condition as specified in Section 4-3.6.1. The concept of net-new impervious surface applies only to Minimum Requirement 6 (Flow Control) and is applied at the threshold discharge area level. (See the definition for effective impervious surface and Figure 3.3, Step 8.)

NOAA Fisheries National Oceanic and Atmospheric Administration, National Marine Fisheries Service.

Noneffective impervious surfaces Those new, applicable replaced, or existing impervious surfaces that are being managed by existing natural dispersion areas meeting the natural dispersion BMP criteria in Section 5-4.2.2.

Noneffective pollution-generating impervious surface (PGIS) Those new, applicable replaced, or existing PGIS surfaces that are being managed by existing natural dispersion areas meeting the natural dispersion BMP criteria in Section 5-4.2.2.

Non-fish-bearing stream According to WAC 222-16-030: type Ns waters are non-fish-habitat streams. Until the fish habitat water type maps are available, an interim water-typing system applies (see WAC 222-16-031). Type 5 waters are non-fish-habitat streams. (See fish-bearing stream definition for more details.)

nonmitigated area The area not included as part of the stormwater treatment.

Non-pollution-generating surface (NPGS) A surface that, based on its use, is an insignificant or low source of pollutants in stormwater runoff. For example, roofs that are subject only to atmospheric deposition or have normal heating, ventilation, and air conditioning vents; paved bicycle pathways and pedestrian sidewalks that are separated from roads used by motor vehicles; fenced fire lanes; infrequently used maintenance access roads; and in-slope areas of roads. Sidewalks that are regularly treated with salt or other deicing chemicals are considered pollution-generating impervious surfaces.

Non-road-related project A project involving structures, including rest areas, maintenance facilities, and ferry terminal buildings.

no-vegetation zone (NVZ) A shallow gravel trench located directly adjacent to the highway pavement.

off-line facilities Runoff treatment facilities to which stormwater runoff is restricted to some maximum flow rate or volume by a flow-splitter.

off-site Any area lying upstream of the project site that drains onto the site and any area lying downstream of the site to which the site drains.

oil control The treatment of stormwater runoff with BMPs to remove oil, grease, and total petroleum hydrocarbons (TPH).

oil/water separator A vault, usually underground, designed to provide a quiescent environment to separate oil from water.

on-line facilities Runoff treatment facilities that receive all the stormwater runoff from a drainage area. Flows above the runoff treatment design flow rate or volume are passed through at a lower-percentage removal efficiency.

on-site The entire property that includes the proposed development.

operational BMP A type of source control BMP that includes schedules of activities, prohibition of practices, and other managerial actions to prevent or reduce pollutants entering stormwater. Operational BMPs include formation of a pollution prevention team; good housekeeping; preventive maintenance procedures; spill prevention and cleanup; employee training; inspections of pollutant sources and BMPs; recordkeeping; process changes; raw material and product changes; and recycling of wastes.

ordinary high water mark (OHWM) The line on the shore established by the fluctuations of water and indicated by physical characteristics such as a clear, natural line impressed on the bank; shelving; changes in the character of soil destruction on terrestrial vegetation; the presence of litter and debris; or other appropriate means that consider the characteristics of the surrounding area. The ordinary high water mark is found by examining the bed and banks of a stream and ascertaining where the presence and action of waters are so common and usual, and so long maintained in all ordinary years, as to mark upon the soil a character distinct from that of the abutting upland, in respect to vegetation. In any area where the ordinary high water mark cannot be found, the line of mean high water is substituted. In any area where neither can be found, the channel bank is substituted. In braided channels and alluvial fans, the ordinary high water mark or substitute must be measured to include the entire stream feature.

organic matter Decomposed animal or vegetable matter, measured by ASTM D 2974. Organic matter is an important reservoir of carbon and a dynamic component of soil and the carbon cycle. It improves soil and plant efficiency by improving soil physical properties including drainage, aeration, and other structural characteristics. It contains the nutrients, microbes, and higher-form soil food web organisms necessary for plant growth. The maturity of organic matter is a measure of its beneficial properties. Raw organic matter can release water-soluble nutrients (similar to chemical fertilizer). Beneficial organic matter has undergone a humification process either naturally in the environment or through a composting process.

orifice An opening with closed perimeter, usually sharp-edged, and of regular form in a plate, wall, or partition through which water may flow; generally used for the purpose of measurement or control of water.

outlet The point of water disposal from a stream, river, lake, tidewater, or artificial drain.

outlet channel A waterway constructed or altered primarily to carry water from manufactured structures, such as terraces, tile lines, and diversions.

outlet protection A protective barrier of rock, erosion control blankets, vegetation, or sod constructed at a conveyance outlet.

outwash soils Soils formed from highly permeable sands and gravels.

overflow A pipeline or conduit device with an outlet pipe that provides for the discharge of portions of combined sewer flows into receiving waters or other points of disposal, after a regular device has allowed the portion of the flow that can be handled by interceptor sewer lines and pumping and treatment facilities to be carried by and to such water pollution control structures.

PAM A large class of polymers (polyacrylamides), some of which have applications in highway construction. PAM products are used as soil stabilizers to prevent erosion, flocculants to remove sediments from stormwater, drilling lubricants, and soil moisture retention enhancers.

particle size The effective diameter of a particle as measured by sedimentation, sieving, or micrometric methods.

peak discharge, peak flow The maximum instantaneous rate of flow during a storm, usually in reference to a specific design storm event.

percolation The movement of water through soil.

percolation rate The rate, often expressed in minutes per inch, at which clear water maintained at a relatively constant depth seeps out of a standardized test hole that has been previously saturated—often used synonymously with *infiltration rate* (short-term infiltration rate).

permeable pavement A permeable surface that readily transmits fluids into the underlying base material. The pavement may be permeable concrete, permeable asphalt, or manufactured systems such as interlocking brick or a combination of sand and brick lattice.

permeable soils Soil materials having a sufficiently rapid infiltration rate so as to greatly reduce or eliminate surface and stormwater runoff; generally classified as Soil Conservation Service hydrologic soil types A and B.

pervious pavement See *permeable pavement*.

pH A measure of the alkalinity or acidity of a substance that is determined by measuring the concentration of hydrogen ions in the substance. A pH of 7.0 indicates neutral water. A 6.5 reading is slightly acidic.

pipe slope drain A pipe extending from the top to the bottom of a cut or fill slope and discharging into a stabilized water course, a sediment-trapping device, or a stabilized outfall.

point of compliance The location at which compliance with a discharge performance standard or a receiving water quality standard is measured.

point source A general classification of the origin of an air or water pollutant, usually characterized as smokestacks or outfalls.

pollution-generating impervious surface (PGIS) An impervious surface that is considered a significant source of pollutants in stormwater runoff, including surfaces that receive direct rainfall (or run-on or blow-in of rainfall) and are subject to vehicular use; industrial activities; or storage of erodible or leachable materials, wastes, or chemicals. Erodible or leachable materials, wastes, or chemicals are substances that, when exposed to rainfall, measurably alter the physical or chemical characteristics of the rainfall runoff. Examples include erodible soils that are stockpiled, uncovered process wastes, manure, fertilizers, oily substances, ashes, kiln dust, and garbage container leakage. Metal roofs are also considered pollution-generating impervious surfaces unless they are coated with an inert, nonleachable material (such as a baked-on enamel coating). A surface, whether paved or not, is considered subject to vehicular use if it is regularly used by motor vehicles. The following are considered regularly used surfaces: roads, unvegetated road shoulders, bicycle lanes within the travel lane of a roadway, driveways, parking lots, unfenced fire lanes, vehicular equipment storage yards, and airport runways. The following are not considered regularly used surfaces: paved bicycle pathways separated from roads for motor vehicles, fenced fire lanes, and infrequently used maintenance access roads.

pollution-generating pervious surface (PGPS) Any nonimpervious surface subject to the ongoing use of pesticides and fertilizers or loss of soil, such as lawns, landscaped areas, golf courses, parks, cemeteries, and sports fields. Grass highway shoulders and medians are not subject to such intensive landscape maintenance practices and are not considered pollution-generating pervious surfaces. It is WSDOT policy to create self-sustaining, native plant communities that require no fertilizer and little to no weed control after they are established. During the plant establishment period, usually the first three years after planting, WSDOT revegetation and mitigation projects are intensely managed to aid plant establishment. However, throughout the life of the project, WSDOT practices integrated vegetation management (IVM), which recognizes herbicides as tools in maintaining planting are as (one of many tools available). Questions regarding whether a specific area may be considered a pollution-generating pervious surface should be directed to the local maintenance area superintendent or the region landscape architect.

porous pavement See *permeable pavement*.

postproject Description of project site conditions after development.

predeveloped condition The modeled site conditions prior to development to which postdevelopment runoff flow rates are matched. (See Minimum Requirement 6 in Chapter 3.)

preproject Description of project site conditions prior to development.

presumptive approach (versus *demonstrative approach*) See Section 1-1.3.

pretreatment The removal of material such as solids, grit, grease, and scum from flows to improve treatability prior to biological or physical treatment processes; may include screening, grit removal, settling, oil/water separation, or application of a basic treatment BMP prior to infiltration.

project Any proposed action to alter or develop a site; the proposed action of a permit application or an approval, which requires drainage review.

project limits For road projects, the beginning project station to the end project station and from right of way line to right of way line. For nonroad projects, the legal boundaries of land parcels that are subject to project development (also called the project area perimeter).

project site The portion of a site to undergo development or redevelopment. For road projects, it is the area between the beginning and ending mileposts within WSDOT right of way. It is defined in the formal project definition agreed upon by the region and Headquarters as to the work to be done, the estimated cost, and the project schedule. For nonroad projects, refer to the definitions for *project limits*.

Puget Sound basin Puget Sound south of Admiralty Inlet (including Hood Canal and Saratoga Passage); the waters north to the Canadian border, including portions of the Strait of Georgia; the Strait of Juan de Fuca south of the Canadian border; and all the lands draining into these waters, as mapped in water resource inventory areas (WRIAs) 1 through 19, set forth in WAC 173-500-040.

rational method A means of computing storm drainage flow rates (Q) by using the formula $Q = CIA$, where C is a coefficient describing the physical drainage area, I is the rainfall intensity, and A is the area. (This method is no longer used in the Washington State Department of Ecology technical manual.)

reach A length of channel with uniform characteristics.

receiving waters Bodies of water or surface water systems to which surface runoff is discharged via a point source of stormwater or via sheet flow.

recharge The addition of water to the zone of saturation (that is, an aquifer).

redevelopment On a site that is already substantially developed (has 35% or more of existing impervious surface coverage): the creation or addition of impervious surfaces; the expansion of a building footprint or addition or replacement of a structure; structural development, including construction, installation, or expansion of a building or other structure; replacement of impervious surface that is not part of a routine maintenance activity; and land disturbing activities.

regional detention facility A stormwater quantity control structure designed to correct surface water runoff problems within a drainage basin or subbasin, such as regional flooding or erosion problems; a detention facility sited to detain stormwater runoff from a number of new developments or areas within a catchment.

release rate The computed peak discharge rate in volume per unit time of surface and stormwater runoff from a site.

replaced impervious surface Those roadway areas that are excavated to a depth at or below the top of the subgrade (pavement repair work excluded) and replaced in kind. The subgrade is taken to be the crushed surfacing directly below the pavement layer (ACP, PCCP, BST). If the removal and replacement of existing pavement does not go below the pavement layer, as with typical PCCP grinding, ACP planing, or “paver” projects, the new surfacing is not considered “replaced impervious surface.” Certain situations that do not include excavation of the existing roadway are also considered replaced impervious surface. (See Section 3-3.6.3 for a discussion of these situations.)

replaced PGIS Those PGIS areas that are removed and replaced in kind by the project, or for roadway areas that are excavated to a depth at or below the top of the subgrade (pavement repair work excluded) and replaced in kind. The subgrade is taken to be the crushed surfacing directly below the pavement layer (ACP, PCCP, BST). If the removal and replacement of existing pavement does not go below the pavement layer, as with typical PCCP grinding, ACP planing, or “paver” projects, the new surfacing is not considered “replaced PGIS.” Certain situations that do not include excavation of the existing roadway are also considered replaced PGIS. (See Section 3-3.5.3 for a discussion of these situations.)

restoration In an area that no longer meets wetland criteria, actions performed to reestablish wetland functional characteristics and processes that have been lost through alterations, land uses, or catastrophic events.

retention The process of collecting and holding surface and stormwater runoff with no surface outflow.

retention/detention facility (R/D) A type of drainage facility designed either to hold water for a considerable length of time and then release it by evaporation, plant transpiration, or infiltration; or to hold surface and stormwater runoff for a short period of time and then release it to the surface and stormwater management system.

retrofit The renovation of an existing structure or facility to meet changed conditions or to improve performance.

return frequency (recurrence interval) A statistical representation of the average time between storm events of a given intensity or size (for example, a stormwater flow that occurs every two years on average).

reversion of existing impervious surfaces Removing an existing impervious surface and restoring that area to a pervious state using the methods shown in Section 4-3.6.1. The flow control benefits for reversion of an existing impervious surface will depend on the level of reversion (Step 1 or Step 2). At this time, the reversion of an existing impervious surface only applies to meeting flow control thresholds. It does not apply to runoff treatment thresholds.

right of way (ROW) Public land devoted to the passage of people and goods. State highway rights of way include state limited access highways inside or outside cities or towns, but not city or town streets forming part of state highway routes that are not limited access highways. The term does not include state property under WSDOT jurisdiction that is outside the right of way lines of a state highway (RCW 90.03.520).

rill A small, intermittent watercourse with steep sides, usually only a few inches deep; often caused by an increase in surface water flow where soil is cleared of vegetation.

riparian Pertaining to the banks of streams, wetlands, lakes, or tidewater.

riprap A facing layer or protective mound of rocks placed to prevent erosion or sloughing of a structure or embankment due to flow of surface and stormwater runoff.

riser A vertical pipe extending from the bottom of a pond that is used to control the discharge rate from a stormwater facility for a specified design storm.

runoff Rainwater or snowmelt that directly leaves an area as a surface drainage.

runoff treatment Pollutant removal to a specified level via engineered or natural stormwater management systems. (Formerly called *water quality treatment*; see Appendix 2B).

runoff treatment BMP A BMP specifically designed for pollutant removal.

salmonid A member of the fish family Salmonidae, including Chinook, coho, chum, sockeye and pink salmon; cutthroat, brook, brown, rainbow, and steelhead trout; and Dolly Varden, kokanee, and char species.

sand filter A constructed depression or basin with a layer of sand that treats stormwater as it percolates through the sand and is discharged via a central collector pipe.

Sanitary Control Areas (SCAs) Well protection buffers.

Santa Barbara Urban Hydrograph method (SBUH) A single-event hydrologic analysis technique for estimating runoff based on the curve number method. The curve numbers are published by the Natural Resources Conservation Service (NRCS) in *Urban Hydrology for Small Watersheds*, 55 TR, June 1976. Updated curve numbers are provided in Appendix 4-B.

scour Erosion of channel banks due to excessive velocity of the flow of surface and stormwater runoff.

SCS Soil Conservation Service (now the Natural Resources Conservation Service), U.S. Department of Agriculture.

SCS method A single-event hydrologic analysis technique for estimating runoff based on the curve number method. The curve numbers are published by the Natural Resources Conservation Service (NRCS) in *Urban Hydrology for Small Watersheds*, 55 TR, June 1976. With the change in name from Soil Conservation Service (SCS) to Natural Resources Conservation Service, the method may be referred to as the NRCS method.

seasonal stream An ephemeral stream.

sediment Fragmented material that originates from weathering and erosion of rocks or unconsolidated deposits and is transported by, suspended in, or deposited by water.

semiarid Description of a geographical area characterized by light rainfall and having about 10 to 20 inches of annual precipitation.

sensitive area Any area designated by a federal, state, or local government as having unique or important environmental characteristics that may require additional protective measures (also see *critical areas*). These areas include but are not limited to:

- “Critical habitat” as defined in Section 3 of the federal Endangered Species Act of 1973.
- Designated “critical water resources” as defined in 33 CFR Part 330, Nationwide Permit Program.
- Water bodies designated as “impaired” under the provision of Section 303d of the federal Clean Water Act enacted by Public Law 92-500.
- Sole-source aquifers as defined under the federal Safe Drinking Water Act, Public Law 93-523.
- Wellhead protection zones as defined under WAC 246-290, Public Water Supplies.
- Areas identified in local critical area ordinances or in an approved basin plan.

sheet flow Runoff that flows over the ground surface as a thin, even layer, not concentrated in a channel.

short-circuiting The passage of runoff through a stormwater treatment facility in less than the design treatment time.

shotcrete Concrete that is placed by means of a spray nozzle, pneumatically applied.

silt fence A temporary sediment barrier consisting of a geotextile fabric stretched across and attached to supporting posts, which are entrenched. Adding rigid wire fence backing can strengthen silt fence.

site The area within the legal boundaries of a parcel (or parcels) of land that is subject to the development project. For road projects, the site is defined by the length of the project and the right of way boundaries.

slope Degree of deviation of a surface from the horizontal, measured as a numerical ratio, percent, or in degrees. Expressed as a ratio, the first number is the horizontal distance (run) and the second is the vertical distance (rise); for example, 2H:1V. A 2H:1V slope is a 50% slope. Expressed in degrees, the slope is the angle from the horizontal plane, so that a 90° slope is vertical (maximum), and a 45° slope is 1H:1V (a 100% slope).

soil The unconsolidated mineral and organic material on the immediate surface of the earth that serves as a natural medium for the growth of land plants. (See also *topsoil*.)

soil amendments Materials that improve soil fertility for establishing vegetation or permeability for infiltrating runoff.

soil drainage As a natural condition of the soil, the frequency and duration of periods when the soil is free of saturation. In well-drained soils, the water is removed readily, but not rapidly; in poorly drained soils, the root zone is waterlogged for long periods unless artificially drained, and the roots of ordinary crop plants cannot get enough oxygen; and in excessively drained soils, the water is removed so completely that most crop plants suffer from lack of water. Strictly speaking, excessively drained soils are a result of excessive runoff due to steep slopes or low available water-holding capacity due to small amounts of silt and clay in the soil material. The following classes are used to express soil drainage:

- Well drained – Excess water drains away rapidly; no mottling occurs within 36 inches of the surface.
- Moderately well drained – Water is removed from the soil somewhat slowly, resulting in small but significant periods of wetness; mottling occurs between 18 and 36 inches.
- Somewhat poorly drained – Water is removed from the soil slowly enough to keep it wet for significant periods but not all the time; mottling occurs between 8 and 18 inches.

- Poorly drained – Water is removed so slowly that the soil is wet for a large part of the time; mottling occurs between 0 and 8 inches.
- Very poorly drained – Water is removed so slowly that the water table remains at or near the surface for a greater part of the time. There may also be periods of surface ponding. The soil has a black-to-gray surface layer with mottles up to the surface.

soil permeability The ease with which gases, liquids, or plant roots penetrate or pass through a layer of soil.

soil stabilization The use of measures such as rock lining, vegetation, or other engineering structures to prevent the movement of soil when loads are applied to the soil.

sole-source aquifer An aquifer or aquifer system that supplies 50% or more of the drinking water for a given service area and for which there are no reasonably available alternative sources should the aquifer become contaminated, and the possibility of contamination exists. The U.S. Environmental Protection Agency designates sole-source aquifers, and Section 1424(e) of the Safe Drinking Water Act is the statutory authority for the Sole-Source Aquifer Protection Program.

source control A structure or operation intended to prevent pollutants from coming into contact with stormwater, either through physical separation of areas or through careful management of activities that are sources of pollutants.

- *Structural source control BMPs* are physical, structural, or mechanical devices or facilities intended to prevent pollutants from entering stormwater.
- *Operational BMPs* are nonstructural practices that prevent or reduce pollutants entering stormwater.

spill control device A tee section or down-turned elbow designed to retain a limited volume of a pollutant that floats on water, such as oil or antifreeze. Spill control devices are passive and must be cleaned out in order to remove the spilled pollutant.

spill prevention, control, and countermeasures (SPCC) plan A plan prepared by a construction contractor, as required in Standard Specification 1-07.15(1), to prevent sediment and other pollutants associated with construction activity from affecting soil, air, and water quality.

spillway A passage, such as a paved apron or channel carrying surplus water over or around a dam or similar obstruction, or an open or closed channel used to convey excess water from a reservoir. A spillway may contain gates, either manually or automatically controlled, to regulate the discharge of excess water.

stabilized construction entrance A construction site entrance that is reinforced or finished with media such as riprap, gravel, or hog fuel to minimize the tracking of sediment onto adjacent streets.

staging area (construction) A site used temporarily during construction for materials or equipment storage, assembly, or other temporary construction activities.

stairstep grading A technique of grading slopes to minimize erosion, in which continuous slopes are replaced with a series of terraces.

Standard Plans WSDOT *Standard Plans for Road, Bridge, and Municipal Construction*. Standardized design drawings for commonly used structures that can be referenced in contracts. The Headquarters Design Office maintains the *Standard Plans*.

Standard Specifications WSDOT *Standard Specifications for Road, Bridge, and Municipal Construction*. Construction requirements for commonly used structures that can be referenced in contracts. The Headquarters Construction Office maintains the *Standard Specifications*.

State Environmental Policy Act (SEPA) The Washington State law (RCW 43.21C) intended to minimize environmental damage; modeled after the National Environmental Policy Act (NEPA). SEPA requires that state agencies and local governments consider environmental factors when making decisions on development proposals over a certain size, comprehensive plans and zoning requirements, and other programmatic proposals. As part of this process, environmental documents are prepared and opportunities for public comment are provided.

steep slope A slope of 40% gradient or steeper within a vertical elevation change of at least 10 feet.

stoloniferous Description of a type of plant having a long shoot that grows from the central rosette and droops to the ground, where it roots to form a new plant.

storm frequency The time interval between major storms of predetermined intensity and volumes of runoff that storm sewers and other structures are designed to handle hydraulically without surcharging and backflooding (for example, a 2-year, 10-year, or 100-year storm).

storm sewer system A sewer that carries stormwater and surface water, street wash, and other washwaters or drainage, but excludes sewage and industrial wastes (also called a storm drain).

stormwater That portion of precipitation that does not naturally percolate into the ground or evaporate, but flows via overland flow, interflow, pipes, and other features of a stormwater drainage system into a defined surface water body or a constructed infiltration facility.

stormwater facility A constructed component of a stormwater drainage system, designed or constructed to perform a particular function or multiple functions. Stormwater facilities include but are not limited to pipes, swales, ditches, culverts, street gutters, detention ponds, retention ponds, constructed wetlands, infiltration devices, catch basins, oil/water separators, and biofiltration swales.

Stormwater Management Manual for Eastern Washington (SMMEW)

A technical manual prepared by the Washington State Department of Ecology containing BMPs intended to prevent, control, and treat pollution in stormwater and to reduce other stormwater-related impacts on waters of the state. The stormwater manual provides guidance on measures necessary in eastern Washington to control the quantity and quality of stormwater runoff from new development and redevelopment.

Stormwater Management Manual for Western Washington (SMMWW)

A technical manual prepared by the Washington State Department of Ecology containing BMPs intended to prevent, control, and treat pollution in stormwater and to reduce other stormwater-related impacts on waters of the state. The stormwater manual provides guidance on measures necessary in western Washington to control the quantity and quality of stormwater runoff from new development and redevelopment.

stormwater outfall Any location where concentrated stormwater runoff leaves the right of way. Outfalls may discharge to surface waters or groundwater.

stream An area where surface waters flow sufficiently to produce a defined channel or bed. A defined channel or bed is an area that demonstrates clear evidence of the passage of water, indicated by hydraulically sorted sediments or the removal of vegetative litter or loosely rooted vegetation by the action of moving water. The channel or bed need not contain water year-round. This definition does not include irrigation ditches, canals, stormwater runoff devices, or other entirely artificial watercourses unless they are used to convey streams naturally occurring prior to construction. Topographic features that resemble streams but have no defined channels (swales) are considered streams when hydrologic and hydraulic analyses performed pursuant to a development proposal predict formation of a defined channel after development.

streambanks The usual boundaries, not the flood boundaries, of a stream channel. Right and left banks are named facing downstream.

structural BMPs Physical, structural, or mechanical devices or facilities intended to prevent pollutants from entering stormwater.

subgrade A layer of stone or soil used as the underlying base for a BMP.

substrate The natural soil base underlying a BMP measure.

swale A natural depression or shallow drainage conveyance with relatively gentle side slopes, generally with flow depths less than 1 foot, used to temporarily store, route, or filter runoff.

tackifier A plant-based or synthetic polymer used to help hydroseed mixes stick together and adhere to the soil. Some tackifiers directly stabilize soil.

take Defined under the federal Endangered Species Act as “harass, harm, pursue, hunt, shoot, wound, kill, trap, capture, or collect or attempt to engage in any such conduct,” including modification to a species habitat. The habitat could be a riparian area, spawning bed, or a rearing area. Changing the hydraulic characteristics of a stream system may result in a habitat alteration and could be considered a *take*. Release of physical, chemical, or biological pollutants into a stream system may result in a *take*.

Technology Assessment Protocol – Ecology (TAPE) A Washington State Department of Ecology process for reviewing and approving new stormwater treatment technologies.

temporary erosion and sedimentation control (TESC) plan A plan that includes all physical and procedural BMPs for preventing erosion and turbid discharges throughout a project and during construction.

terrace An embankment or combination of an embankment and channel across a slope to control erosion by diverting or storing surface runoff instead of permitting it to flow uninterrupted down the slope.

threatened species Any species (other than pest insects) likely to become endangered within the foreseeable future throughout all or a significant portion of its range.

threshold discharge area (TDA) An on-site area draining to a single natural discharge location or multiple natural discharge locations that combine within ¼ mile downstream (as determined by the shortest flow path).

tight-line A continuous length of aboveground pipe that conveys water from one point to another (typically down a steep slope) with no inlets or collection points in between.

till A layer of poorly sorted soil deposited by glacial action that generally has very low infiltration rates.

time of concentration The time necessary for surface runoff to reach the outlet of a subbasin from the hydraulically most remote point in the tributary drainage area.

tire wash A facility for washing mud off vehicles to prevent track-out of sediment.

topsoil Surface soil presumed to be fertile and used to cover planting areas. Topsoil must meet ASTM D 5268 Standard Specification, and water permeability must be 0.6 inches per hour or greater. Organic matter must have no more than 10% of nutrients in mineralized water-soluble forms. Topsoil must not have phytotoxic characteristics.

total maximum daily load (TMDL) – Water Cleanup Plan A calculation of the maximum amount of a pollutant that a water body can receive and still meet water quality standards and an allocation of that amount to the pollutant's sources. A TMDL (also known as a Water Cleanup Plan) is the sum of allowable loads of a single pollutant from all contributing point sources and nonpoint sources. The calculation must include a margin of safety to ensure the water body can be used for the purposes the state has designated. The calculation must also account for seasonal variation in water quality. Water quality standards are set by states, territories, and tribes. They identify the uses for each water body; for example, drinking water supply, contact recreation (such as swimming), and aquatic support (such as fishing) and the scientific criteria to support each use. The federal Clean Water Act, Section 303, establishes the water quality standards and TMDL programs.

total petroleum hydrocarbons (TPH) TPH-Gx: the qualitative and quantitative method (extended) for volatile (gasoline) petroleum products in water; and TPH-Dx: the qualitative and quantitative method (extended) for semivolatile (diesel) petroleum products in water.

total suspended solids (TSS) That portion of the solids carried by stormwater that can be captured on a standard glass filter.

toxic Poisonous, carcinogenic, or otherwise directly harmful to life.

track walking A technique for roughening soils on slopes to reduce erosion, involving systematically covering soils with cleat marks that run perpendicular to the slope, for detaining and infiltrating runoff.

trash rack A structural device used to prevent debris from entering a spillway or other hydraulic structure.

travel time The estimated time for surface water to flow between two points of interest.

treatment liner A layer of soil designed to slow the rate of infiltration and provide sufficient pollutant removal to protect groundwater quality.

treatment train A combination of two or more treatment facilities connected in series.

triangular silt dike A geotextile-encased foam check dam.

trip end The expected number of vehicles using a parking area, represented by the projected trip end counts for the parking area associated with a proposed land use. Trip end counts are estimated using either *Trip Generation* (published by the Institute of Transportation Engineers) or a traffic study prepared by a professional engineer or transportation specialist with expertise in traffic volume estimation. Trip end counts must be made for the design life of the project. For project sites with seasonal or varied use, the highest period of expected traffic impacts is evaluated.

turbidity Dispersion or scattering of light in a liquid, caused by suspended solids and other factors; commonly used as a measure of suspended solids in a liquid. Turbidity is a state-regulated parameter. Turbidity can be measured in the field with a hand-held meter and is recorded in nephelometric turbidity units (NTU).

underdrain Plastic pipes with holes drilled through the top, installed on the bottom of an infiltration facility, that are used to collect and remove excess runoff.

underground injection control (UIC) well A bored, drilled, or driven shaft whose depth is greater than the largest surface dimension; a dug hole whose depth is greater than the largest surface dimension; an improved sinkhole; a subsurface fluid distribution system that includes an assemblage of perforated pipes, drain tiles, or other similar mechanisms intended to distribute fluids below the surface of the ground. Examples of UIC wells or subsurface infiltration systems are drywells, drainfields, and french drains that include pipes and other similar devices that discharge to ground. Underground Injection Control is a federal regulatory program established to protect underground sources of drinking water from UIC well discharges.

unstable slope A sloping area of land that at any time exhibits mass movement of earth.

upgrade The replacement of paved areas with a better surface or in a way that enhances the traffic capacity of the road.

urban growth area (UGA) Those areas designated by a county according to RCW 36.70A.110.

urbanized area An area designated and identified by the U.S. Bureau of Census according to the following criteria: a densely settled area that has a minimum residential population of 50,000 people and a minimum average density of 1,000 people per square mile.

Vector truck A vacuum truck used to remove the waste material found in the bottom of a catch basin.

vault See *dry vault or tank* and *wet vault or tank*.

vegetated filter strip A facility designed to provide runoff treatment of conventional pollutants (but not nutrients) through the process of biofiltration.

vertical curve The up and down component of a roadway curve.

water bar A small ditch cut perpendicular to the flow of water in roads or hillsides. A cross-sectional view reveals a ditch with the excavated material placed on the downslope side.

water body Surface waters including rivers, streams, lakes, marine waters, estuaries, and wetlands.

Water Cleanup Plan See *total maximum daily load*.

water quality A term used to describe the chemical, physical, and biological characteristics of water, usually in respect to its suitability for a particular purpose.

water quality standards The minimum requirements for water purity for uses like drinking water supply, contact recreation (such as swimming), and aquatic support (such as fishing). The Washington State Department of Ecology sets water quality standards for Washington State. Surface water and groundwater standards are established in WAC 173-201A and WAC 173-200, respectively.

water quality treatment See *runoff treatment*.

water resource inventory area (WRIA) A geographic area within which water drains into a particular river, stream, or receiving water body, identified and numbered by the state of Washington (defined in WAC 173-500).

watershed A geographic region within which water drains into a particular river, stream, or body of water. Watersheds can be as large as those identified and numbered by the state of Washington as water resource inventory areas (WRIAs), defined in WAC 173-500.

waters of the state All surface waters and watercourses within the jurisdiction of the state of Washington, including lakes, rivers, ponds, streams, inland waters, undergroundwaters, saltwaters, and wetlands.

water table The upper surface or top of the saturated portion of the soil or bedrock layer, indicating the uppermost extent of groundwater.

wattle Temporary erosion and sediment control barriers consisting of any plant material that is wrapped in biodegradable fiber, tubular plastic, or similar encasing material. Wattles are typically 8 to 10 inches in diameter and 25 to 30 feet in length.

weir A device for measuring or regulating the flow of water.

wetland functions See *functions/wetland*.

wetlands Areas that are inundated or saturated by surface water or groundwater at a frequency and duration sufficient to support a prevalence of vegetation typically adapted for life in saturated soil conditions. Wetlands generally include swamps, marshes, bogs, and similar areas. They do not include artificial wetlands intentionally created from nonwetland sites, including but not limited to irrigation and drainage ditches, grass-lined swales, canals, detention facilities, wastewater treatment facilities, farm ponds, and landscape amenities; or wetlands unintentionally created after July 1, 1990, as a result of construction of a road, street, or highway. Wetlands may include artificial wetlands intentionally created from nonwetland areas to mitigate adverse impacts resulting from the conversion of wetlands. (Water bodies not included in this definition of wetlands, as well as those mentioned in the definition, are still waters of the state.)

wet pond A facility that provides water quality treatment for stormwater by using a permanent pool of water to remove conventional pollutants from runoff through sedimentation, biological uptake, and plant filtration. Wet ponds are designed to (1) optimize water quality by providing retention time in order to settle out particles of fine sediment to which pollutants such as heavy metals absorb and (2) to allow biological activity to occur that metabolizes nutrients and organic pollutants.

wet vault or tank Underground storage facility that treats stormwater for water quality through the use of a permanent pool of water that acts as a settling basin. It is designed (1) to optimize water quality by providing retention time in order to settle out particles of fine sediment that absorb pollutants such as heavy metals and (2) to allow biological activity to occur that metabolizes nutrients and organic pollutants.